

SMD High Frequency Power Inductor

Designed for VRD & VRM 10.x & 11.x Applications

FEATURES

- Recommended for use with all major Voltage Regulator ICs
- High Current handling capability in the smallest footprint & profile
- Up to 2MHz operating frequency
- Extended operating temperature range: -40C to 125C
- Robust SMD package capable of handling the most aggressive SMT assembly process
- RoHS compliant version available

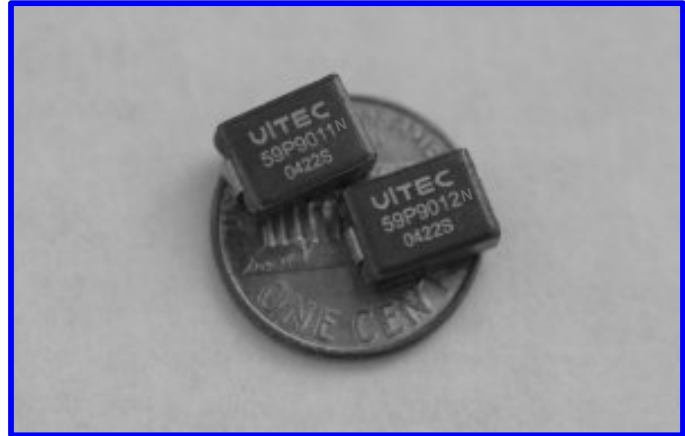

APPLICATIONS

- VRD and VRM 10.x and 11.x based designs
- Multi-Phase Voltage regulator designs
- Server, Desktop, PDA, Graphics cards, Notebook computers, DDR, telecom switches and routers
- DC-DC converters, Battery powered devices, high current power supplies
- High Current NPUs in networking equipment
- Point-of-load Modules
- DCR Sensing

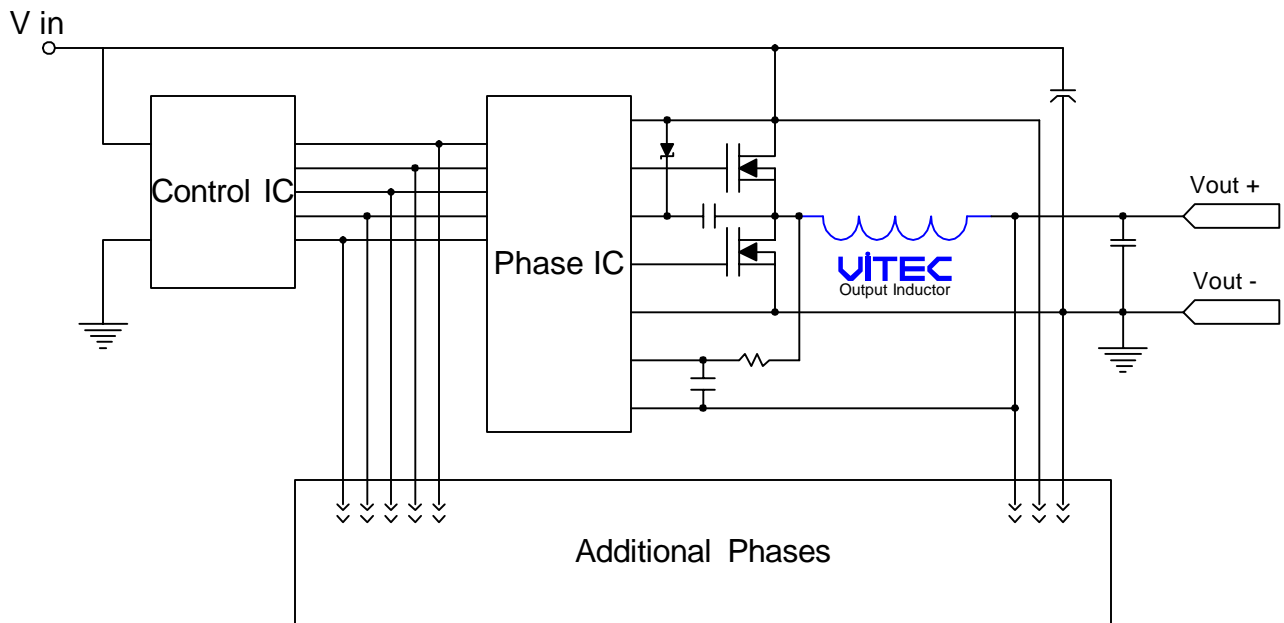

Typical Multi-Phase Application Circuit for a Buck Converter

SMD High Frequency Power Inductor

Designed for VRD & VRM 10.x & 11.x Applications

PACKAGE

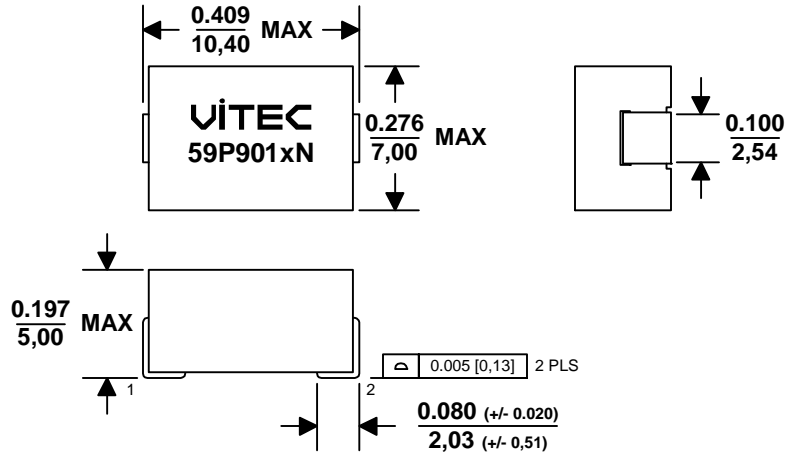

Dimensions: Inches/mm. Tolerances: +/- 0.010"/0,25mm unless otherwise noted

SCHEMATIC

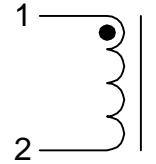

SUGGESTED PCB LAYOUT

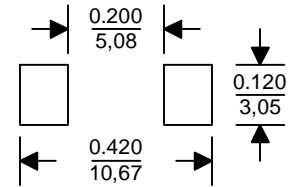

Drawing NOT to scale

ELECTRICAL CHARACTERISTICS @ 25°C (unless otherwise noted)

| Part Number | | Inductance @ 0Adc ⁴ | Inductance @ Irated ⁴ | Irated ¹ | DCR | Saturation Current ² | | | Temp. Rise Current ³ | Temp. Rise Factor ⁵ |
|-------------|-----------|--------------------------------|----------------------------------|---------------------|-----------------|---------------------------------|-------------|--------------|---------------------------------|--------------------------------|
| Classic | RoHS | nH ± 10% | nH MIN | ADC MAX | mOhm +/- 10% | ADC -40°C | ADC 25°C | ADC 125°C | ADC MAX | |
| 59P9010N | 59PR9010N | 90 | 65 | 63 | 0.47 | 64 | 63 | 50 | 27 | 0.02631 |
| 59P9011N | 59PR9011N | 125 | 90 | 45 | 0.47 | 46 | 45 | 36 | 27 | 0.03663 |
| 59P9012N | 59PR9012N | 160 | 115 | 35 | 0.47 | 36 | 35 | 28 | 27 | 0.04694 |
| 59P9013N | 59PR9013N | 210 | 151 | 27 | 0.47 | 28 | 27 | 21 | 27 | 0.06165 |

Add an "R" to the part number after "P" for the RoHS compliant version (i.e. 59PR9011N is the RoHS compliant version of 59P9011N).

Notes:

- The rated current is the saturation current @ 25°C.
- The I(Saturation) is the current at which the inductance drops by 20% maximum of its value at 0ADC. This current is measured at the stated ambient environment and by applying a short duration pulse current to the component, minimizing the self-heating effects.
- The I (Temp. Rise) is the current at which the temperature of the part increases by a maximum of 50°C. This test is performed with the part mounted on a PCB with traces having 1.7 times the cross sectional area of the copper leads and applying the DC current for a minimum of 30 minutes.
- Inductance is measured at 100 KHz and 1.0 Vrms.
- Temperature Rise can be estimated using the following formulas:

$$T_{rise} (°C) = \left(\frac{\text{Core Loss} + \text{DCR Loss}}{3.06} \right)^{0.833}$$

$$\text{DCR Loss (mW)} = \left(I_{dc}^2 + \left(\frac{\Delta I}{2} \right)^2 \right) \times \text{TYP DCR (mOhms)}$$

$$\text{Core Loss (mW)} = 0.002636 \times (F)^{1.84} \times (\text{Temp. Rise factor} \times \Delta I)^{2.28}$$

IDC = DC output current (ADC)

Δ I = Delta I across the inductor (Amps)

F = Switching frequency (kHz)

SMD High Frequency Power Inductor

Designed for VRD & VRM 10.x & 11.x Applications

59P9010N Inductance vs. I_{dc} @ 25°C

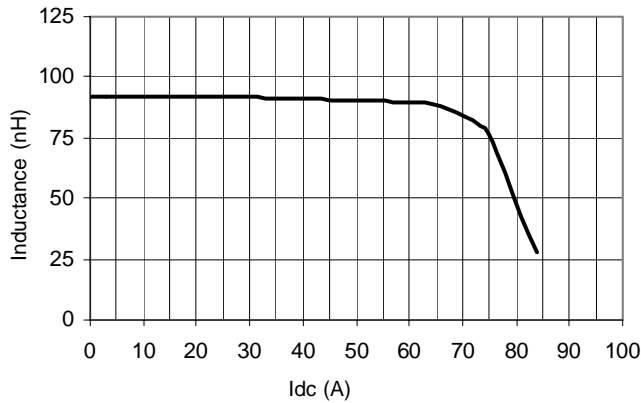

59P9011N Inductance vs. I_{dc} @ 25°C

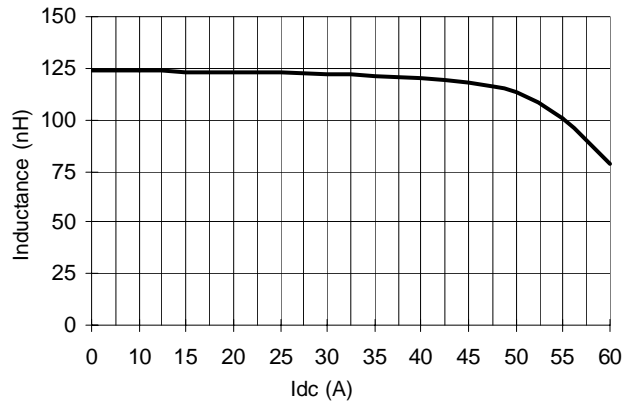

59P9012N Inductance vs. I_{dc} @ 25°C

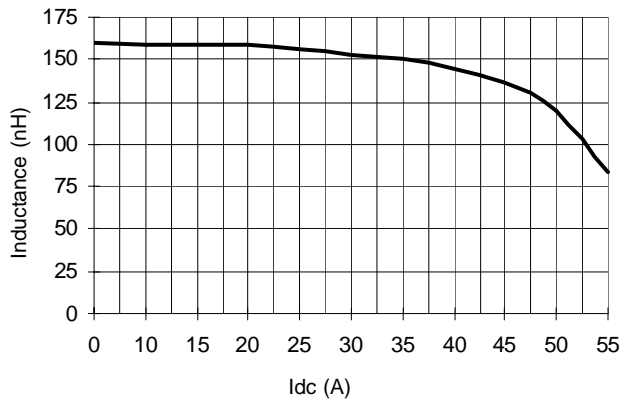

59P9013N Inductance vs. I_{dc} @ 25°C

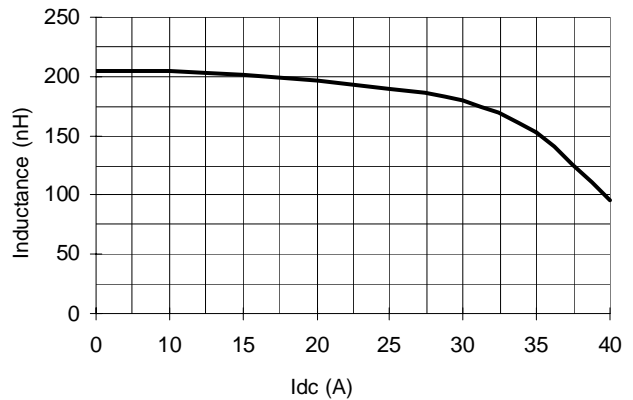

59P901xN Temp. Rise vs. I_{dc}

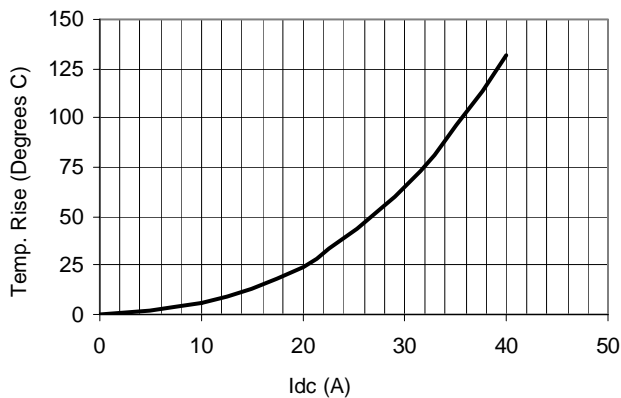

59P901xN R_{dc} vs. Temp. Rise

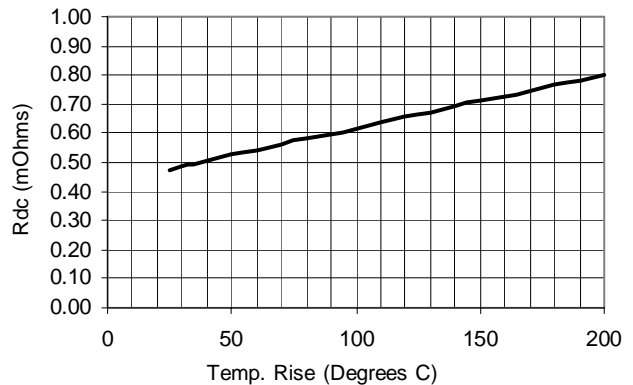

ENVIRONMENTAL & RELIABILITY DATA

Storage Temperature: -40C to +125C
 Operating Temperature: -40C to +125C
 Resistance to Solder Reflow: 3 passes thru. +235C for 30 seconds minimum

Marking permanency: Tested per JESD22-B107-A
 Solderability: Tested per MIL-STD-750D
 Life Test: Tested per MIL-STD-202F, Method 108A
 Thermal Cycle: Tested per JESD22-B104-B, Test Condition G

SMD High Frequency Power Inductor

Designed for VRD & VRM 10.x & 11.x Applications

IR Profile

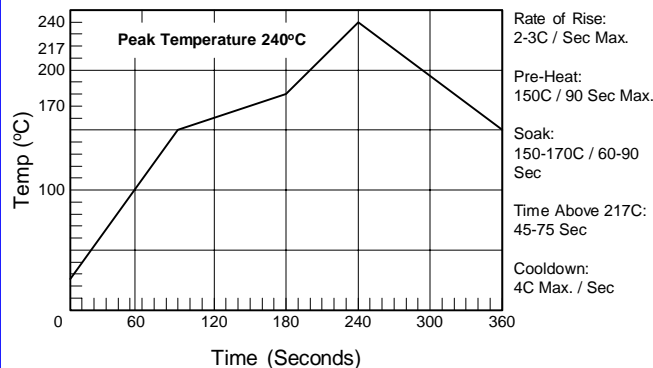

Tape and Reel

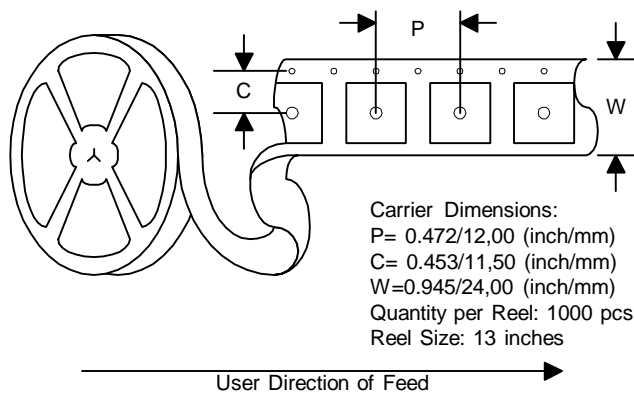

ABOUT US

Vitec Electronics Corporation, founded in 1986, is a worldwide leader in the design, manufacture and sale of magnetic solutions. Vitec's market focus includes the power, power conditioning, telecom, networking, communications and computing. Vitec has also established strong alliances with chip manufacturers whereby magnetic solutions are designed in conjunction with unique silicon requirements and are offered as reference designs by the chip companies.

With its Corporate Headquarters and Research & Development center located in Carlsbad, California, and its state of the art manufacturing facility and material sourcing in China, Vitec is uniquely positioned to supply the latest technology at the lowest cost. Vitec offers both standard and custom product design capabilities with all of its facilities being ISO certified.

QUALITY POLICY

Vitec will provide products and services that meet or exceed our Customer's requirements, conform to company policies and standards, and exhibit continuously improving levels of Quality.

COMMITMENT

VITEC Electronics empowers each of its employees by providing a business environment that encourages a commitment to excellence, a sense of ownership and personal accountability to all Vitec Customers.

Competitive Pricing, Quality Products, and On Time Deliveries are expected from today's World Class Magnetics Suppliers. The high standards of today's customer are strengthening the dedication and commitment of VITEC Electronics to provide Total Customer Service.

CONTACT US

USA

VITEC ELECTRONICS CORPORATION
6213 El Camino Real
Carlsbad, CA 92009
U.S.A.

TEL: +1 (760) 918-8831
FAX: +1 (760) 918-8840

ASIA

SHANGHAI VITEC ELECTRONICS CO., LTD.
3369 He Chuan Road
Min Hang District, Shanghai, 201103
China

TEL: +86 (21) 6446-4828
FAX: +86 (21) 6446-4865