

# SMD High Frequency Power Inductor

## Designed for VRD & VRM 10.x & 11.x Applications

### FEATURES

- Recommended for use with all major Voltage Regulator ICs
- High Current handling capability in the smallest footprint & profile
- Up to 2MHz operating frequency
- Extended operating temperature range: -40°C to 125°C
- Robust SMD package capable of handling the most aggressive SMT assembly process
- RoHS compliant component



### APPLICATIONS

- VRD and VRM 10.x and 11.x based designs
- Multi-Phase Voltage regulator designs
- Server, Desktop, PDA, Graphics cards, Notebook computers, DDR, telecom switches and routers
- DC-DC converters, Battery powered devices, high current power supplies
- High Current NPUs in networking equipment
- Point-of-load Modules
- DCR Sensing

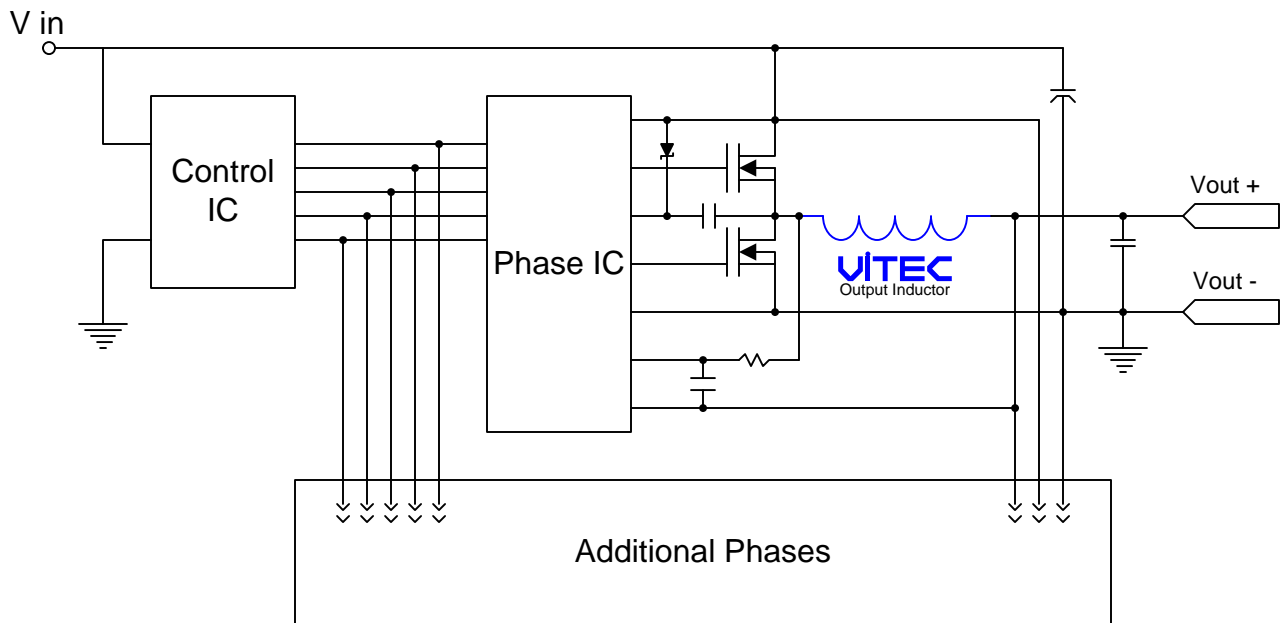

Typical Multi-Phase Application Circuit for a Buck Converter

# SMD High Frequency Power Inductor

## Designed for VRD & VRM 10.x & 11.x Applications

### PACKAGE

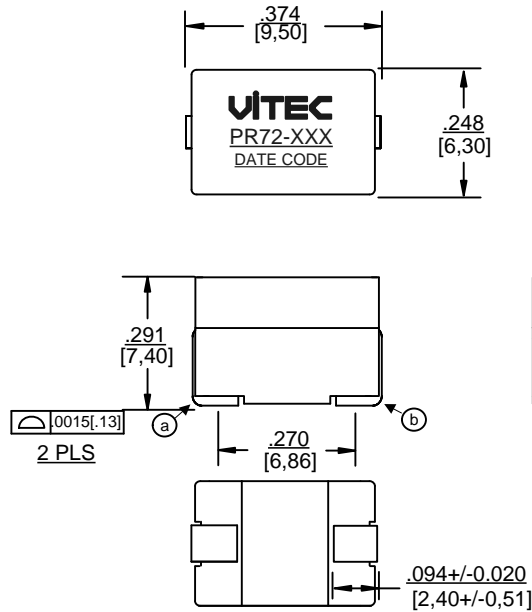

Dimensions: Inches/mm. Tolerances: +/- 0.008"/0,20mm unless otherwise noted

### SCHEMATIC

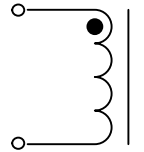

### 59PR72-XXX Temp. Rise vs. Idc

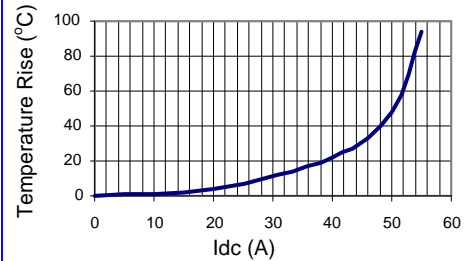

### SUGGESTED PCB LAYOUT

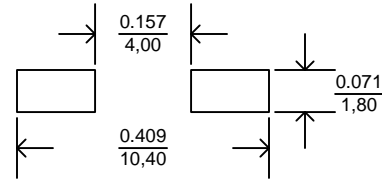

Drawing NOT to scale

### ELECTRICAL CHARACTERISTICS @ 25°C (unless otherwise noted)

Part Number	Inductance @ 0Adc	Inductance @ Irated <sup>1</sup>	Irated <sup>1</sup>	DCR	MAX Saturation Current <sup>2</sup>			Temp. Rise Current <sup>3</sup>	Temp. Rise Factor <sup>5</sup>
	nH	nH	ADC	mOhms	ADC			ADC	
	+/- 10%	MIN	MAX	+/- 5%	25°C	100°C	125°C	MAX	
59PR72-101	100	72.0	95	0.29	95	80	76	50	0.021
59PR72-121	120	86.4	81	0.29	81	69	66	50	0.025
59PR72-151	150	108.0	66	0.29	66	56	53	50	0.035
59PR72-181	180	129.0	54	0.29	54	45	42	50	0.038
59PR72-221	220	158.0	45	0.29	45	41	39	50	0.044
59PR72-281	280	201.0	35	0.29	35	32	30	50	0.059
59PR72-301	300	216.0	33	0.29	33	30	28	50	0.062

### Notes:

- The rated current is the saturation current @ 25°C.
- The I(Saturation) is the current at which the inductance drops by 20% maximum of its value at 0ADC. This current is measured at the stated ambient environment and by applying a short duration pulse current to the component, minimizing the self-heating effects.
- The I (Temp. Rise) is the current at which the temperature of the part increases by a maximum of 50°C. This test is performed with the part mounted on a PCB with traces having 1.7 times the cross sectional area of the copper leads and applying the DC current for a minimum of 30 minutes.
- Inductance is measured at 100 KHz and 1.0 Vrms.
- DCR is measured at point Ⓐ to point Ⓑ
- Temperature Rise can be estimated using the following formulas:

$$Trise (°C) = \left( \frac{\text{Core Loss} + \text{DCR Loss}}{6.619} \right)^{0.833}$$

$$\text{DCR Loss (mW)} = \left( Idc^2 + \left( \frac{\Delta I}{2} \right)^2 \right) \times \text{TYP DCR (mOhms)}$$

$$\text{Core Loss (mW)} = 0.00418 \times (F)^{1.62} \times (\text{Temp. Rise factor} \times \Delta I)^{2.95}$$

IDC = DC output current (ADC)  
 $\Delta I$  = Delta I across the inductor (Amps)  
 F = Switching frequency (kHz)

# SMD High Frequency Power Inductor

## Designed for VRD & VRM 10.x & 11.x Applications

59PR72-101 Inductance vs. I<sub>dc</sub> @ 25°C

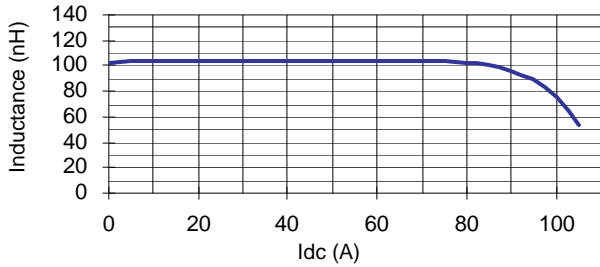

59PR72-121 Inductance vs. I<sub>dc</sub> @ 25°C

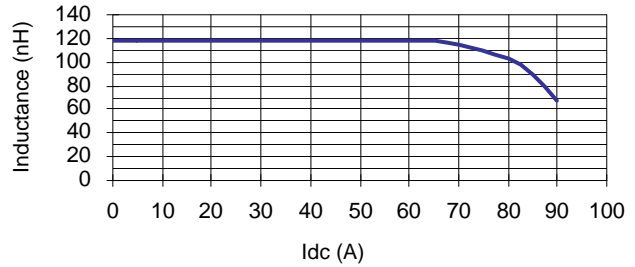

59PR72-151 Inductance vs. I<sub>dc</sub> @ 25°C

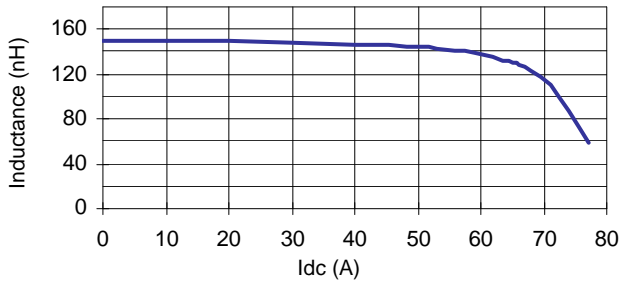

59PR72-181 Inductance vs. I<sub>dc</sub> @ 25°C

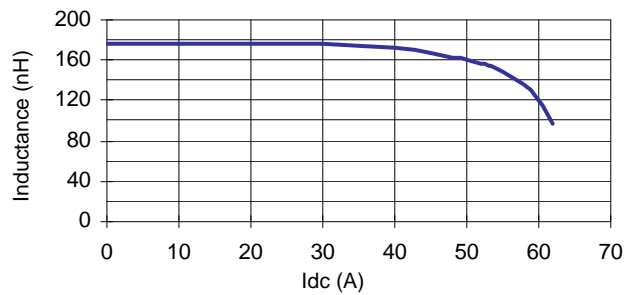

59PR72-221 Inductance vs. I<sub>dc</sub> @ 25°C

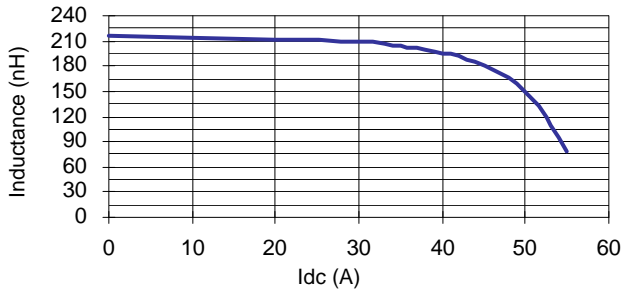

59PR72-281 Inductance vs. I<sub>dc</sub> @ 25°C

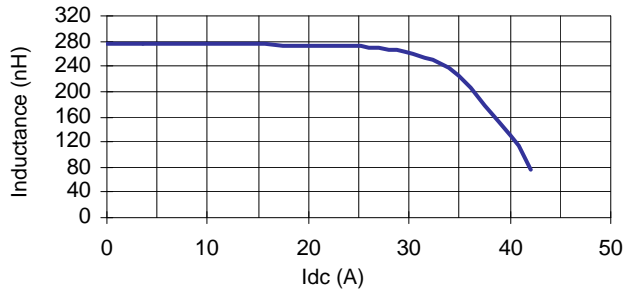

59PR72-301 Inductance vs. I<sub>dc</sub> @ 25°C

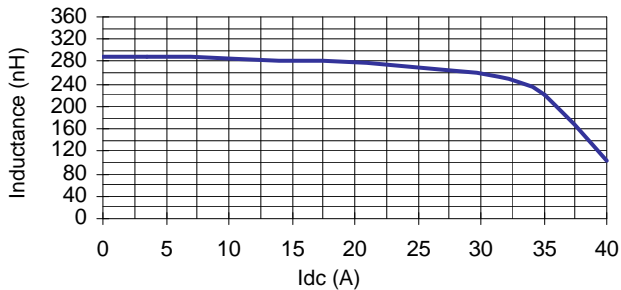

59PR72-XXX R<sub>dc</sub> vs. Temp. Rise

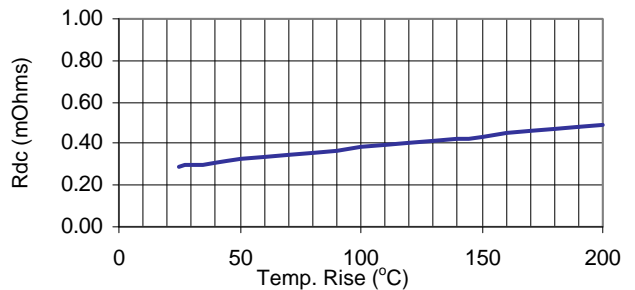

### ENVIRONMENTAL & RELIABILITY DATA

Storage Temperature: -40C to +125C  
 Operating Temperature: -40C to +125C  
 Resistance to Solder Reflow: 3 passes thru. +245C for 30 seconds minimum

Marking permanency: Tested per JESD22-B107-A  
 Solderability: Tested per MIL-STD-750D  
 Life Test: Tested per MIL-STD-202F, Method 108A  
 Thermal Cycle: Tested per JESD22-A104-B, Test Condition G

# SMD High Frequency Power Inductor

## Designed for VRD & VRM 10.x & 11.x Applications

### IR Profile

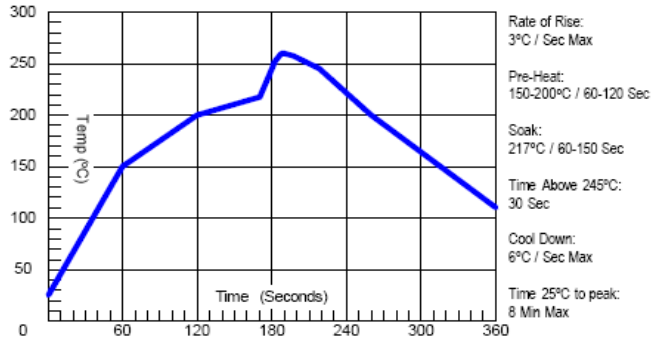

### Tape and Reel

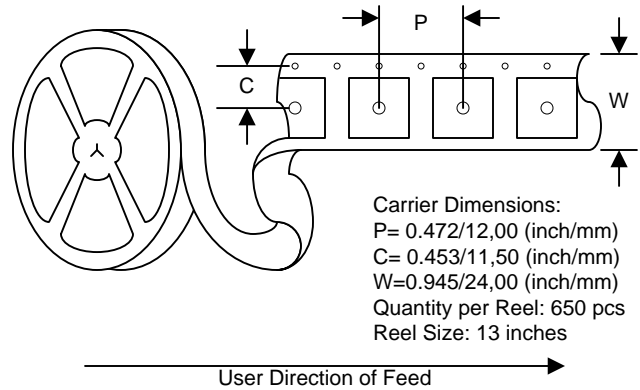

### ABOUT US

Vitec Electronics Corporation, founded in 1986, is a worldwide leader in the design, manufacture and sale of magnetic solutions. Vitec's market focus includes the power, power conditioning, telecom, networking, communications and computing. Vitec has also established strong alliances with chip manufacturers whereby magnetic solutions are designed in conjunction with unique silicon requirements and are offered as reference designs by the chip companies.

With its Corporate Headquarters and Research & Development center located in Carlsbad, California, and its state of the art manufacturing facility and material sourcing in China, Vitec is uniquely positioned to supply the latest technology at the lowest cost. Vitec offers both standard and custom product design capabilities with all of its facilities being ISO certified.

### QUALITY POLICY

Vitec will provide products and services that meet or exceed our Customer's requirements, conform to company policies and standards, and exhibit continuously improving levels of Quality.

### COMMITMENT

VITEC Electronics empowers each of its employees by providing a business environment that encourages a commitment to excellence, a sense of ownership and personal accountability to all Vitec Customers.

Competitive Pricing, Quality Products, and On Time Deliveries are expected from today's World Class Magnetics Suppliers. The high standards of today's customer are strengthening the dedication and commitment of VITEC Electronics to provide Total Customer Service.

### CONTACT US

USA

VITEC ELECTRONICS CORPORATION  
6213 El Camino Real  
Carlsbad, CA 92009  
U.S.A.

TEL: +1 (760) 918-8831  
FAX: +1 (760) 918-8840

ASIA

SHANGHAI VITEC ELECTRONICS CO., LTD.  
3369 He Chuan Road  
Min Hang District, Shanghai, 201103  
China

TEL: +86 (21) 6446-4828  
FAX: +86 (21) 6446-4865