

VITEC

POWER INDUCTOR
CATALOG
VRM, VRD, DDR, POL

INNOVATIONS IN MAGNETICS™

UI



EI



HI



EE



COUPLED



EIE



INNOVATIONS IN MAGNETICS

WELCOME TO VITEC ELECTRONICS

Welcome, and thank you for your interest in Vitec Electronics Corporation. Vitec, a multi-national company established in 1986, is a worldwide supplier of innovative magnetic solutions. With design centers in North America and Asia, along with a state-of-the-art manufacturing facility in China, Vitec is uniquely positioned to provide both innovative and cost-effective magnetic solutions. Every Vitec professional shares my vision, my commitment, and my passion for excellence in every program, on every system, and in every effort that supports our customers around the world. We are very proud of Vitec's growing reputation as "The Magnetics of Choice" within customers, among our many industry partners, and throughout the magnetics industry. I sincerely thank you for your interest in Vitec Electronics Corporation.



Brad Rogers
General Manager

WORLDWIDE SALES & CUSTOMER SERVICE

Vitec Electronics Corporation employs multiple authorized distributors and representative offices for its sales operations worldwide. Sales management and customer service in the continental United States, Puerto Rico, Canada, Mexico, Brazil, and Europe are conducted from corporate headquarters in Carlsbad, California, and for all of Asia from Shanghai, China.



Vitec Shanghai Electronics



DESIGN & DEVELOPMENT

Vitec's comprehensive, in-house tooling capability – including jigs, fixtures and automation equipment – combined with the use of innovative materials and manufacturing techniques ensure the most cost-effective solution to your yield and performance objectives. Our product capability ranges from high-volume standard surface-mount and thru-hole inductors to short-run, high-power custom transformers. Our highly trained and dedicated engineering, technical and customer-support staff will oversee your project from design and prototyping through production and delivery, ensuring the highest standards of product performance, consistency and reliability.

POWER INDUCTORS

VRM, VRD, DDR, POL

PRODUCT SELECTION MATRIX

Part Number	Energy Storage Capability		Maximum Size (mm)			Package	Coil Type	Page
	Inductance Range (nH)	MAX Current (Adc)	L	W	H			
55P5xxx	100 - 5000	100	13.21 - 18.54	7.84 - 11.44	12.70 - 16.53	Toroidal - THT	Wire Wound	1
59P890x	50 - 580	90	13.46	12.95	8.00	UI - SMT	Staple	7
59P9001 59P9002 59P9003 59P9022 59P9024	30 - 450	100	7.62	7.49	4.96	UI - SMT	Staple	9
59P901x	90 - 580	63	10.40	7.00	5.00	UI - SMT	Staple	13
59P901xN	90 - 580	63	10.40	7.00	5.00	UI - SMT	Staple	17
59P9043 59P9044 59P22-152	100 - 4000	50	10.90	9.00	6.50	EI - SMT	Flat	21
59P9051 59P9052N 59P9052 59P8971	50 - 2000	35	8.00 8.00 8.00 8.00	7.70	4.50	EI - SMT	Flat	23
59P9071 59P9073	50 - 150	50	9.65	9.65	2.54 - 3.81	EI - SMT	Flat	29
59P9090 59P9091 59P8970 59P8972	100 - 3000	30	6.15	5.87	5.79	HI - SMT	Wire Wound	31
59P987x	120 - 1000	76	10.92	7.20	7.50	UI - SMT	Staple	41
59P987xN	120 - 1000	76	10.92	7.20	7.50	UI - SMT	Staple	45
59P988x	50 - 470	75	11.18	11.18	9.00	UI - SMT	Staple	49
59P9891	100 - 3000	40	14.00	9.00	12.00	EIE - SMT	Flat - Dual	53
59P9892 59P9892N	50 - 580	45	10.90	7.20	6.50	UI - SMT	Staple	55
59P9893	100 - 1000	50	10.90	8.20	7.50	EE - THT	Wire Wound	59
59P21-xxx	50 - 1000	25	5.00	5.00	3.00	EE - SMT	Flat	61
59P31-xxx	720	35	10.40	13.00	6.00	EI - SMT	Flat	67
59P32-xxx	1000	33	10.40	13.00	7.50	EI - SMT	Flat	69
59P51-xxx	50 - 470	85	7.60	7.40	7.00	UI - SMT	Staple	71
59P53-xxx	75 - 470	43	7.00	7.00	4.00	UI - SMT	Staple	73
59P54-xxx	70 - 220	40	7.00	7.00	4.96	UI - SMT	Staple	75
59P55-xxx	120 - 470	75	10.90	7.20	6.50	UI - SMT	Staple	79
59P57-xxx	120 - 200	25	10.40	7.00	4.30	UI - SMT	Staple	83
59P58-xxx	70 - 220	40	7.00	7.00	4.96	UI - SMT	Staple	85
59P59-xxx	85 - 220	70	10.20	7.00	4.96	UI - SMT	Staple	87
59P61-xxx	32 - 200	112	7.20	7.00	5.10	UI - SMT	Staple	91
59P63-xxx	70 - 510	137	10.80	7.20	7.50	UI - SMT	Staple	95
59P65-xxx	65	24	3.80	3.80	3.80	UI - SMT	Staple	99

APPLICATIONS

- Voltage Regulator Modules (VRM)
- Voltage Regulator Down (VRD)
- Point of Load (POL)
- Double Data Rate (DDR)
- Server, Work Stations, Notebook Computers, PDA, Telecom switches and Routers, Graphics Cards
- DC-DC Converters, Battery Powered Devices, High Current, High Frequency Power Supplies

130508



High Frequency Power Inductor

Designed for Multi-Phase Voltage Regulator Applications

FEATURES

- Recommended for use with Voltage Regulator ICs
- High Current handling capability in a small footprint
- 100KHz to 2MHz operating frequency
- Extended operating temperature range: -40C to 125C
- Ferrite based design with a very low Core Loss
- No thermal aging issues
- Litz wire for reduced skin effect
- Toroidal Design for efficient thermal management
- Meets flammability requirements of UL 94V-0
- Manufactured to UL recognized 155C insulation system (UL File#E107307)

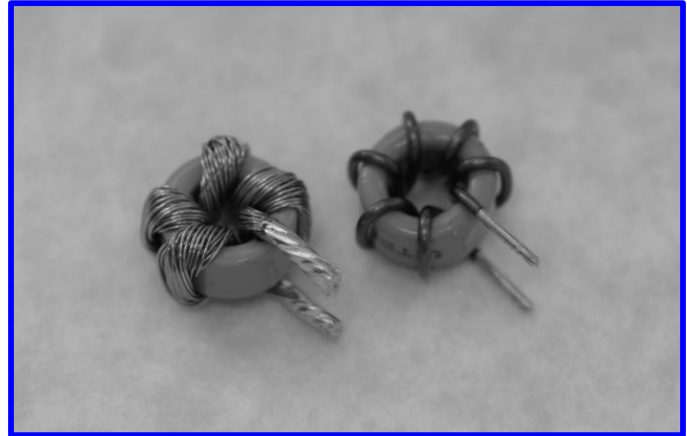

APPLICATIONS

- VRD 9.x, 10.x and 11.x based designs
- Multi-Phase Voltage regulator designs
- Server, Desktop, Graphics cards, Notebook computers, DDR, telecom switches and routers
- DC-DC converters, Battery powered devices, high current power supplies
- High Current NPUs in networking equipment

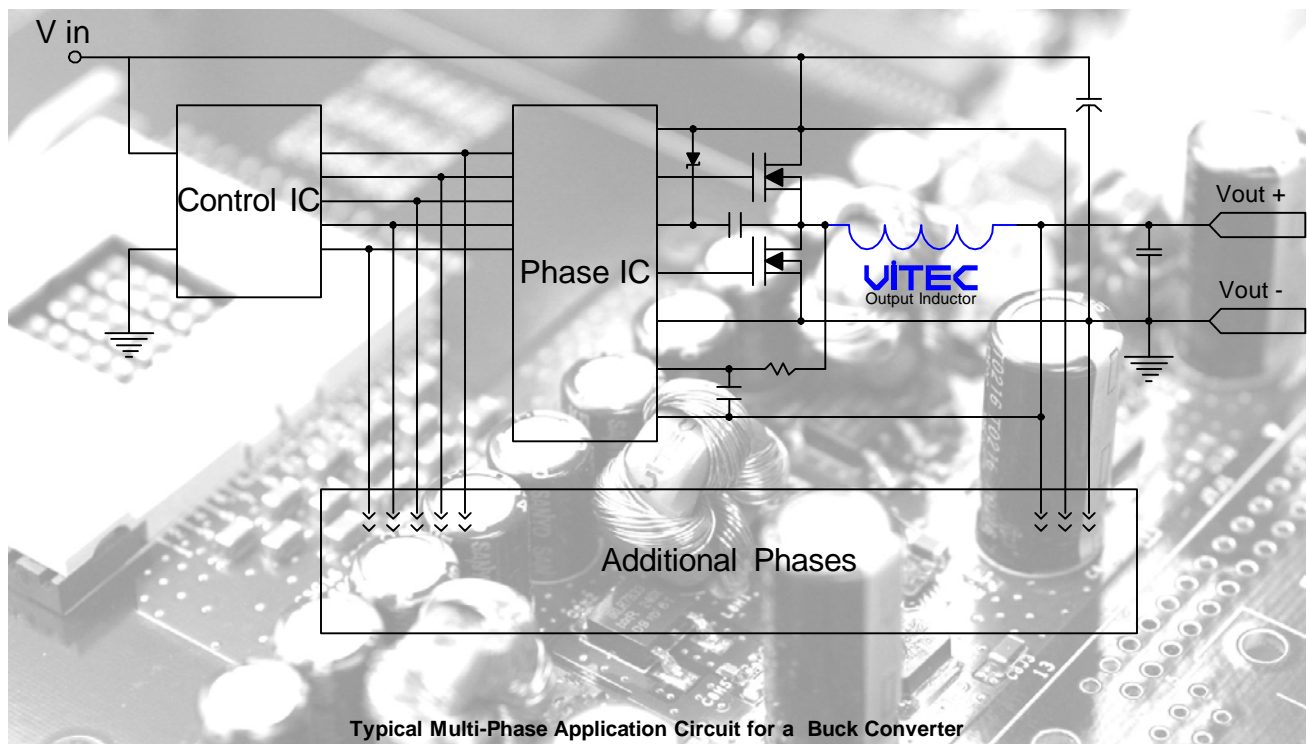

High Frequency Power Inductor

Designed for Multi-Phase Voltage Regulator Applications

PACKAGE 1

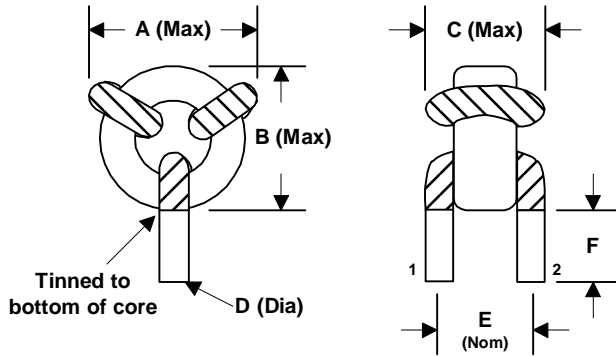

PACKAGE 2

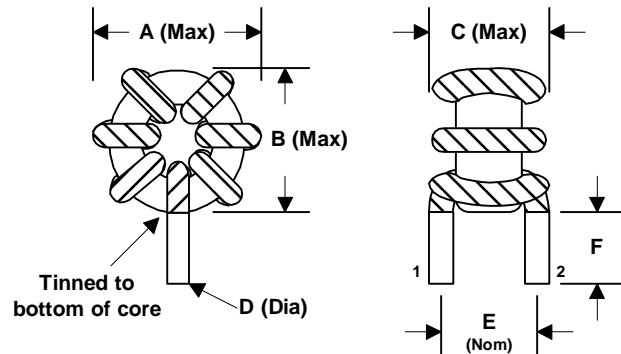

PACKAGE 3

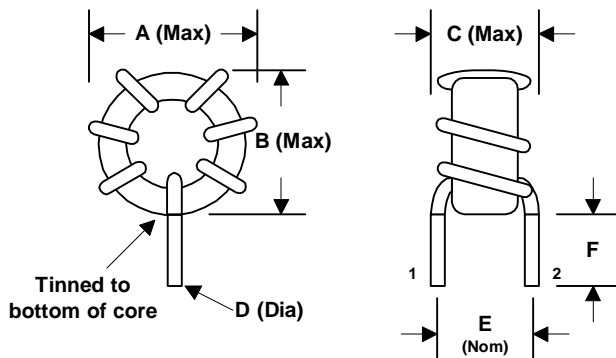

PACKAGE 4

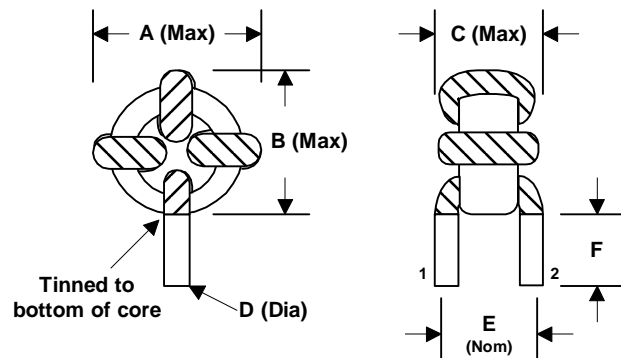

PACKAGE 5

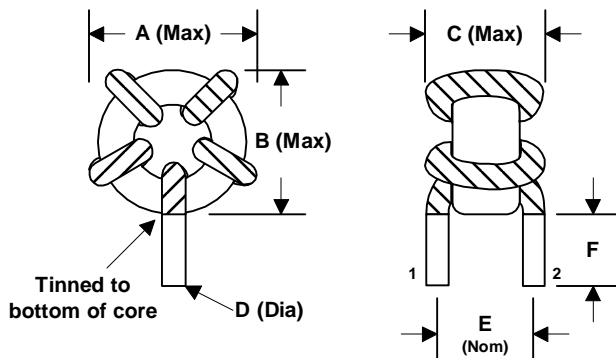

DIMENSIONS

P/N (package)		A	B	C	D	E	F
55P9263	1	0.710 18,03	0.570 14,48	0.450 11,44	0.100 2,54	0.320 8,13	0.250 - 0.350 6,35 - 8,89
55P9323	2	0.690 17,53	0.650 16,53	0.440 11,18	0.070 1,78	0.350 8,89	0.200 - 0.300 5,08 - 7,62
55P9327	3	0.520 13,21	0.500 12,71	0.340 8,64	0.035 0,89	0.265 6,74	0.230 - 0.270 5,84 - 6,86
55P9328	4	0.730 18,54	0.660 16,76	0.450 11,44	0.095 2,41	0.350 8,89	0.200 - 0.300 5,08 - 7,62
55P9331	4	0.730 18,54	0.660 16,76	0.430 10,92	0.095 2,41	0.350 8,89	0.250 - 0.350 6,35 - 8,89
55P9344	1	0.710 18,03	0.560 14,22	0.450 11,44	0.100 2,54	0.300 7,62	0.250 - 0.350 6,35 - 8,89
55P9345	5	0.550 13,97	0.500 12,70	0.360 9,14	0.080 2,03	0.270 6,86	0.250 - 0.350 6,35 - 8,89
55P9346	5	0.690 17,53	0.600 15,24	0.380 9,65	0.080 2,03	0.350 8,89	0.200 - 0.300 5,08 - 7,62
55P9347	4	0.630 16,00	0.520 13,21	0.350 8,89	0.100 2,54	0.270 6,86	0.250 - 0.350 6,35 - 8,89

Dimensions: Inches/mm. Tolerances: +/- 0.010"/0,25mm unless otherwise noted

High Frequency Power Inductor

Designed for Multi-Phase Voltage Regulator Applications

ELECTRICAL CHARACTERISTICS @ 25°C (unless otherwise noted)

Part Number		Inductance @ 0Adc ⁴	Inductance @ Irated ⁴	Irated ¹	DCR		MAX Saturation Current ²			Temp. Rise Current ³	Temp. Rise Factor ⁵
Classic	RoHS compliant	nH	nH	ADC	mOhm		ADC	ADC	ADC	ADC	
		± 10%	MIN	MAX	TYP	MAX	-40°C	25°C	125°C	MAX	
55P9263	55PR9263	310	223	70	0.49	0.55	73	70	50	38	0.0192
55P9323	55PR9323	1800 (+/- 15%)	1224	24	1.80	2.00	25	24	21	26	0.0739
55P9327	55PR9327	1250	900	23	3.30	3.80	25	23	15	14	0.0911
55P9328	55PR9328	470	338	62	0.64	0.72	64	62	43	37	0.0338
55P9331	55PR9331	330	238	80	0.64	0.72	83	80	60	36	0.0237
55P9344	55PR9344	200	144	98	0.46	0.55	100	98	68	38	0.0197
55P9345	55PR9345	610	439	26	1.15	1.45	28	26	19	27	0.0612
55P9346	55PR9346	1000	720	34	1.15	1.50	36	34	26	28	0.0575
55P9347	55PR9347	310	230	44	0.67	0.74	47	44	37	34	0.0395

Add an "R" to the part number after "P" for the RoHS compliant version (i.e. 55PR9263 is the RoHS compliant version of 55P9263).

Notes:

- 1 - The rated current is the saturation current @ 25°C.
- 2 - The I(Saturation) is the current at which the inductance drops by 20% maximum of its value at 0ADC. This current is measured at the stated ambient environment and by applying a short duration pulse current to the component, minimizing the self-heating effects.
- 3 - The I(Temp. Rise) is the current at which the temperature of the part increases by a maximum of 50°C. This test is performed with the part mounted on a PCB with 0.250" wide, 0.004" thick copper traces and applying the DC current for a minimum of 30 minutes.
- 4 - Inductance is measured at 100 KHz and 1.0 Vrms.
- 5 - The additional Temperature Rise due to High ET (Voltage x Time) can be estimated using the following formula:

$$\text{Trise (}^{\circ}\text{C)} = \left(\frac{\text{Core Loss} + \text{DCR Loss}}{A \text{ (see table)}} \right)^{0.833}$$

$$\text{DCR Loss} = \left(\text{Idc}^2 + \left(\frac{\Delta I}{2} \right)^2 \right) \times \text{DCR (Typ)}$$

$$\text{Core Loss} = B \times (F)^{1.84} \times (\text{Temp. Rise Factor} \times \Delta I)^{2.2}$$

ΔI = Delta I across the inductor

F = Switching Frequency (kHz)

Part #	TABLE	
	A	B
55P9263	7.25	0.0072
55P9323	7.25	0.0072
55P9327	5.49	0.0033
55P9328	7.25	0.0072
55P9331	7.25	0.0072
55P9344	7.25	0.0072
55P9345	5.49	0.0033
55P9346	7.25	0.0072
55P9347	5.49	0.0033

SCHEMATIC

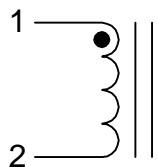

SUGGESTED PCB LAYOUT

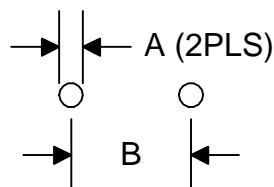

Drawing NOT to scale

Part #	A	B
55P9263	0.120 / 3,05	0.320 / 8,13
55P9323	0.090 / 2,29	0.350 / 8,89
55P9327	0.050 / 1,27	0.265 / 6,73
55P9328	0.120 / 3,05	0.350 / 8,89
55P9331	0.120 / 3,05	0.350 / 8,89
55P9344	0.120 / 3,05	0.300 / 7,62
55P9345	0.090 / 2,28	0.270 / 6,86
55P9346	0.100 / 2,54	0.350 / 8,89
55P9347	0.120 / 3,05	0.270 / 6,86

Dimension (inch / mm)

High Frequency Power Inductor

Designed for Multi-Phase Voltage Regulator Applications

55P9263 Temperature Rise vs. I_{dc}

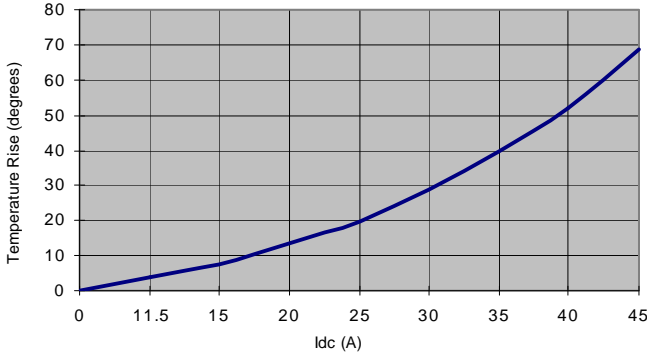

55P9263 Inductance vs. I_{dc} @ 25°C

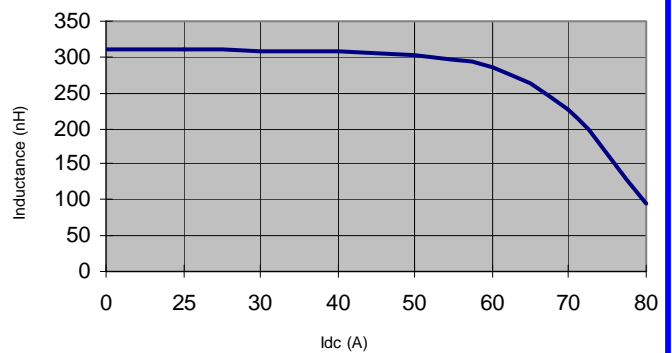

55P9323 Temperature Rise vs. I_{dc}

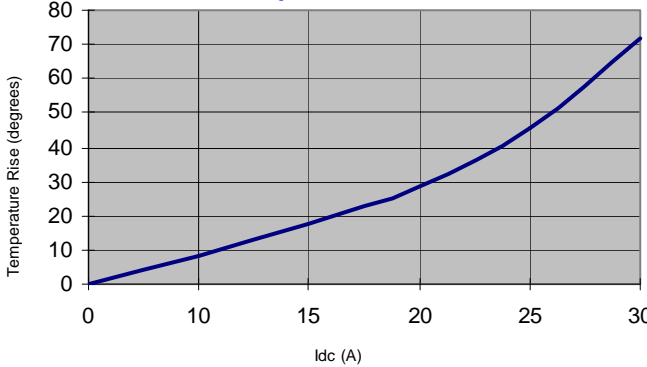

55P9323 Inductance vs. I_{dc} @ 25°C

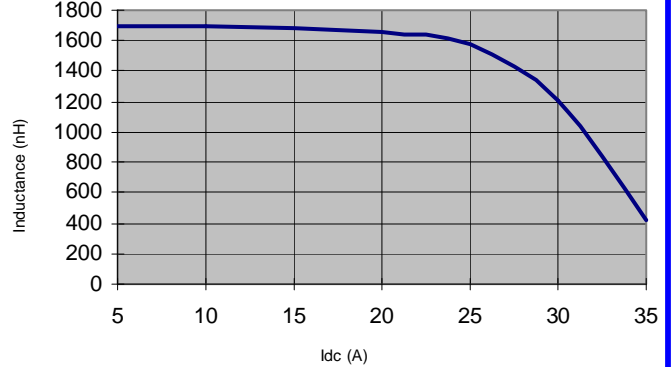

55P9327 Temperature Rise vs. I_{dc}

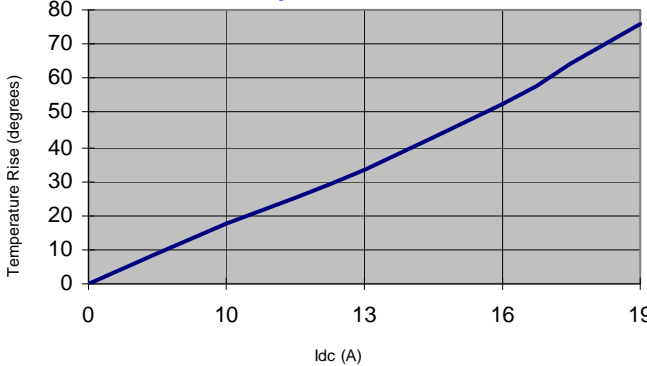

55P9327 Inductance vs. I_{dc} @ 25°C

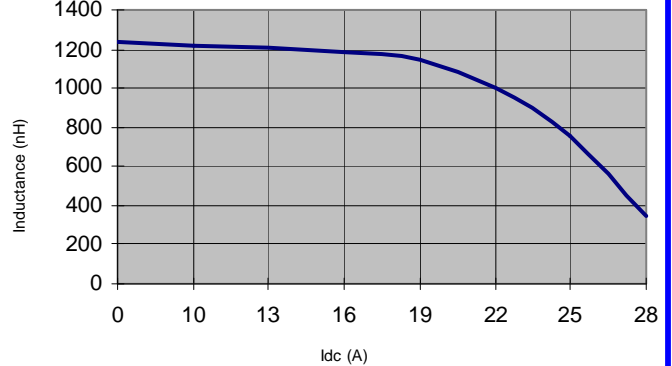

55P9328 Temperature Rise vs. I_{dc}

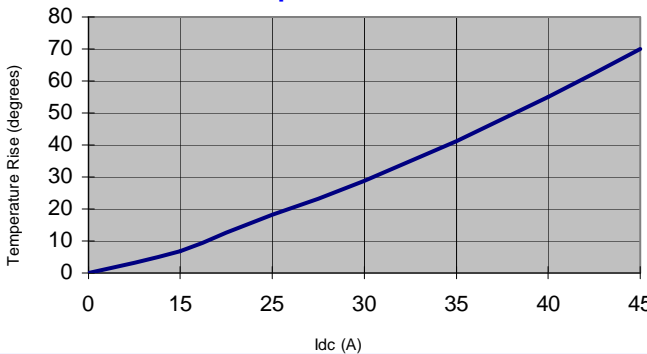

55P9328 Inductance vs. I_{dc} @ 25°C

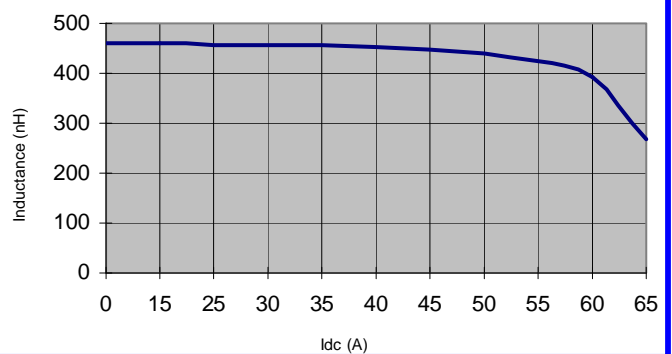

High Frequency Power Inductor

Designed for Multi-Phase Voltage Regulator Applications

55P9331 Temperature Rise vs. I_{dc}

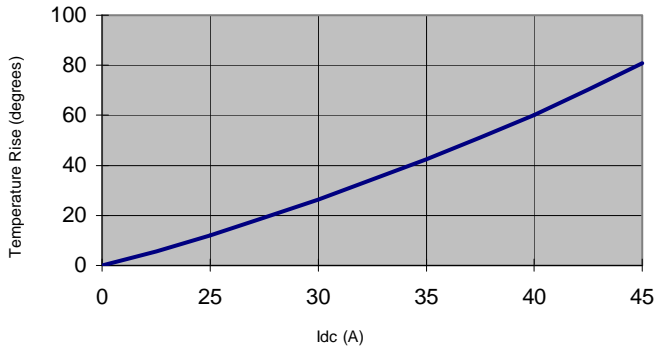

55P9331 Inductance vs. I_{dc} @ 25°C

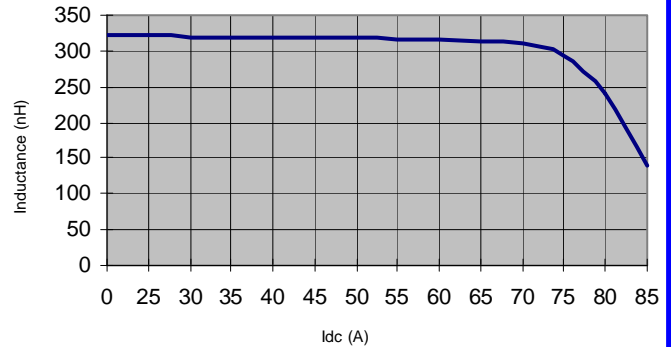

55P9344 Temperature Rise vs. I_{dc}

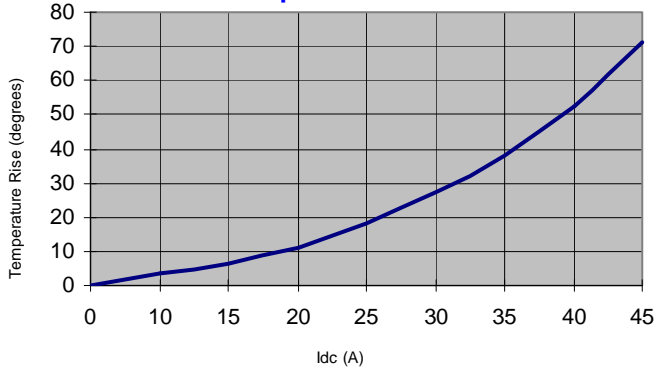

55P9344 Inductance vs. I_{dc} @ 25°C

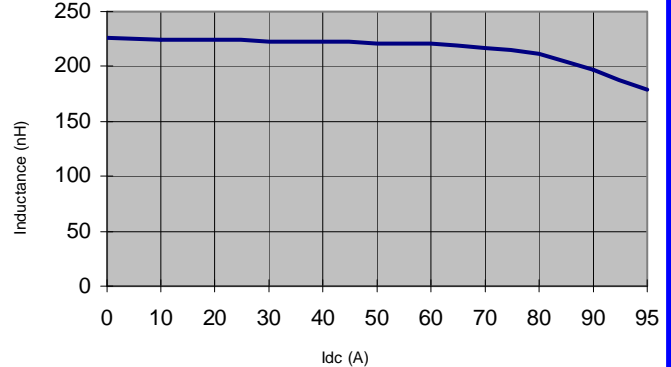

55P9345 Temperature Rise vs. I_{dc}

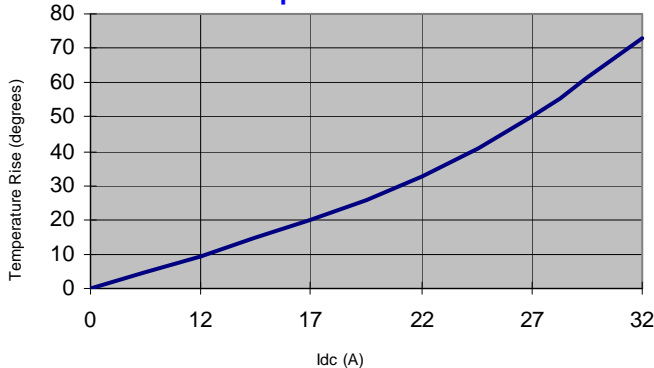

55P9345 Inductance vs. I_{dc} @ 25°C

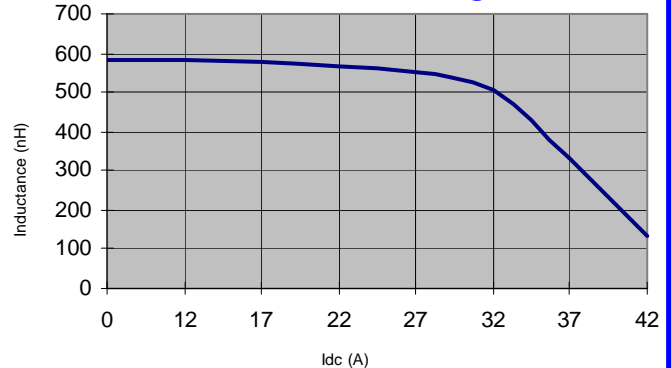

55P9346 Temperature Rise vs. I_{dc}

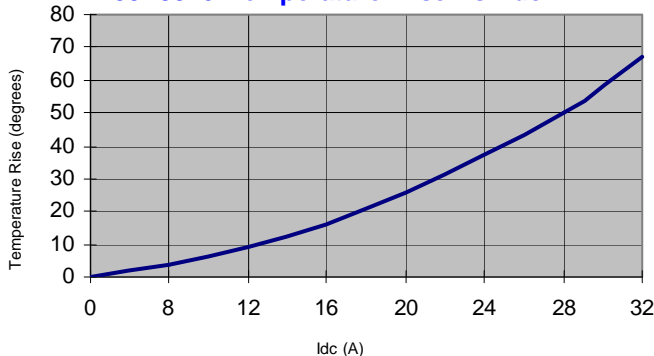

55P9346 Inductance vs. I_{dc} @ 25°C

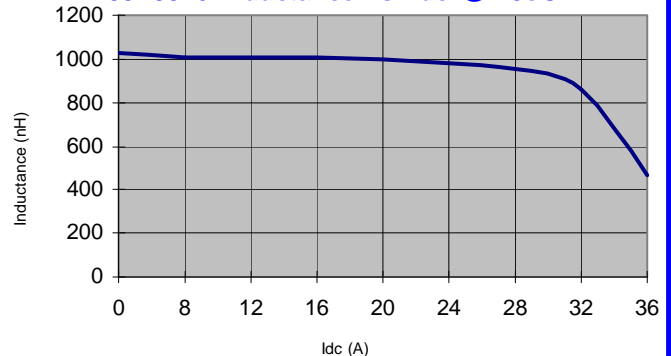

High Frequency Power Inductor

Designed for Multi-Phase Voltage Regulator Applications

55P9347 Temperature Rise vs. I_{dc}

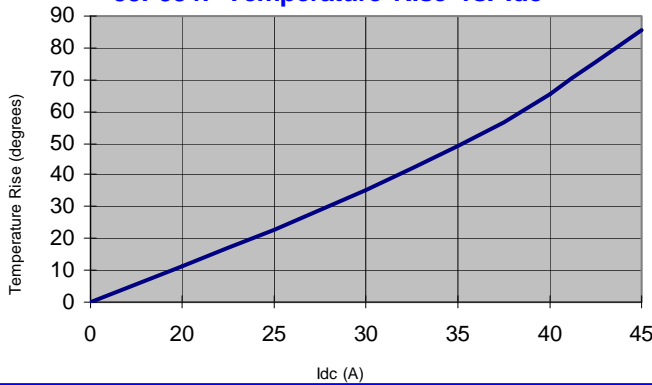

55P9347 Inductance vs. I_{dc} @ 25oC

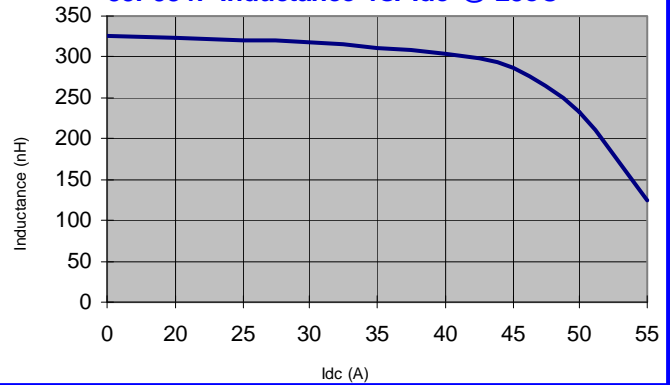

ENVIRONMENTAL & RELIABILITY DATA

Storage Temperature: -40C to +125C
Operating Temperature: -40C to +125C
Resistance to Solder Reflow: 3 passes thru. +235C for 30 seconds minimum

Marking permanency: Tested per JESD22-B107-A
Solderability: Tested per MIL-STD-750D
Life Test: Tested per MIL-STD-202F, Method 108A
Thermal Cycle: Tested per JESD22-B104-B, Test Condition G

ABOUT US

Vitec Electronics Corporation, founded in 1986, is a worldwide leader in the design, manufacture and sale of magnetic solutions. Vitec's market focus includes the power, power conditioning, telecom, networking, communications and computing. Vitec has also established strong alliances with chip manufacturers whereby magnetic solutions are designed in conjunction with unique silicon requirements and are offered as reference designs by the chip companies.

With its Corporate Headquarters and Research & Development center located in Carlsbad, California, and its state of the art manufacturing facility and material sourcing in China, Vitec is uniquely positioned to supply the latest technology at the lowest cost. Vitec offers both standard and custom product design capabilities with all of its facilities being ISO certified.

QUALITY POLICY

Vitec will provide products and services that meet or exceed our Customer's requirements, conform to company policies and standards, and exhibit continuously improving levels of Quality.

COMMITMENT

VITEC Electronics empowers each of its employees by providing a business environment that encourages a commitment to excellence, a sense of ownership and personal accountability to all Vitec Customers.

Competitive Pricing, Quality Products, and On Time Deliveries are expected from today's World Class Magnetics Suppliers. The high standards of today's customer are strengthening the dedication and commitment of VITEC Electronics to provide Total Customer Service.

CONTACT US

USA

VITEC ELECTRONICS CORPORATION
6213 El Camino Real
Carlsbad, CA 92009
U.S.A.

TEL: +1 (760) 918-8831
FAX: +1 (760) 918-8840

ASIA

SHANGHAI VITEC ELECTRONICS CO., LTD.
3369 He Chuan Road
Min Hang District, Shanghai, 201103
China

TEL: +86 (21) 6446-4828
FAX: +86 (21) 6446-4865

SMD High Frequency Power Inductor

59P890X

FEATURES

- Designed For Use With Advanced Voltage Regulator ICs
- Operating Frequency of 0.100 - 2.0 MHz
- Extended Operating Temperature Range of -40°C to 125°C
- High Current Handling Capability in the Smallest Footprint

MECHANICAL

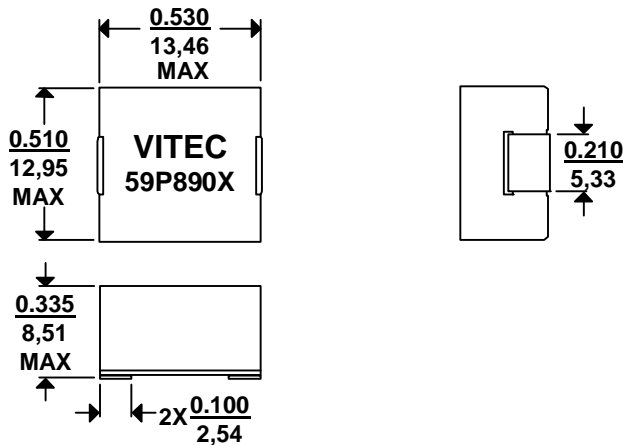

Dimensions Inches/mm +/- 0.010"/0,25mm Unless noted

SCHEMATICS

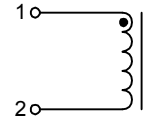

SUGGESTED PCB LAYOUT

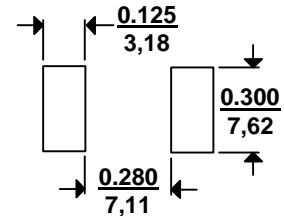

ELECTRICAL CHARACTERISTICS @ 25°C

Part Number		Application Inductance	Inductance @ 0A _{dc} ⁴	Inductance @ I _{rated} ⁴	I _{rated} ¹	DCR	MAX Saturation Current ²			Temp. Rise Current ³	Temp. Rise Factor ⁵
Classic	RoHS	nH	nH ± 10%	nH MIN	ADC MAX	mOhm ± 10%	ADC -40°C	ADC 25°C	ADC 125°C	ADC MAX	
59P8900	59PR8900	100	110	79	120	.165	122	120	105	68	0.0113
59P8901	59PR8901	200	210	152	71	.165	74	71	61	68	0.0226
59P8902	59PR8902	250	260	187	60	.165	63	60	50	68	0.0282
59P8903	59PR8903	300	320	230	45	.165	49	45	41	68	0.0339
59P8904	59PR8904	410	440	317	32	.165	33	32	25	68	0.0463

Add an "R" to the part number after "P" for the RoHS compliant version (i.e. 59PR8900 is the RoHS compliant version of 59P8900).

Notes:

- 1 - The rated current is the saturation current @ 25°C.
- 2 - The I(Saturation) is the current at which the inductance drops by 20% maximum of its value at 0ADC. This current is measured at the stated ambient environment and by applying a short duration pulse current to the component, minimizing the self-heating effects.
- 3 - The I(Temp. Rise) is the current at which the temperature of the part increases by a maximum of 50°C. This test is performed with the part mounted on a PCB with 0.250" wide, 0.004" thick copper traces and applying the DC current for a minimum of 30 minutes.
- 4 - Inductance is measured at 100 KHz and 1.0 V_{rms}.
- 5 - The additional Temperature Rise due to High ET (Voltage x Time) can be estimated using the following formula:

$$\text{Trise (}^{\circ}\text{C)} = \left(\frac{\text{Core Loss} + \text{DCR Loss}}{10.93} \right)^{0.833}$$

$$\text{DCR Loss} = \left(\text{Idc}^2 + \left(\frac{\Delta I}{2} \right)^2 \right) \times .21$$

$$\text{Core Loss} = 0.0168 \times (F)^{1.84} \times (\text{Temp. Rise Factor} \times \Delta I)^{2.2}$$

Δ I = Delta I across the inductor

F = Switching Frequency (kHz)

This drawing is the property of Vitec Electronics Corporation. It is not a controlled document. Therefore it is subject to change without prior notice. It's intended use is to supply preliminary information only. Duplication of all or any part of this drawing is prohibited.

AF4142-44 082109

This page intentionally left blank

SMD High Frequency Power Inductor

Designed for Advanced Voltage Regulator Modules

FEATURES

- Recommended for use with Volterra's 3rd Generation Advanced Regulator Modules.
- Tested and approved by Volterra.
- High current handling capability in the smallest footprint & profile.
- Up to 2MHz operating frequency.
- Extended operating temperature range: -40°C to 125°C.
- Robust SMD package and RoHS compliant.

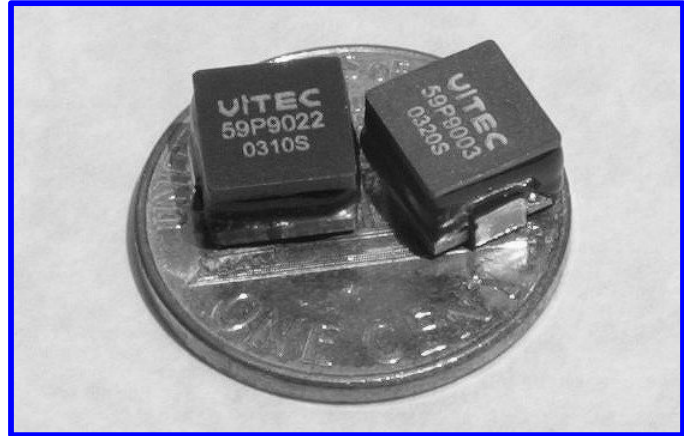

APPLICATIONS

- Multi-Phase synchronous Buck Voltage Regulator designs.
- Low voltage, high current, high frequency, DC-DC voltage regulator modules (LVRMs).
- Server, Desktop, PDA, Graphic Cards, Notebook Computers, Telecom Switches and Routers.
- DC-DC Converters, battery powered devices, high current power supplies.

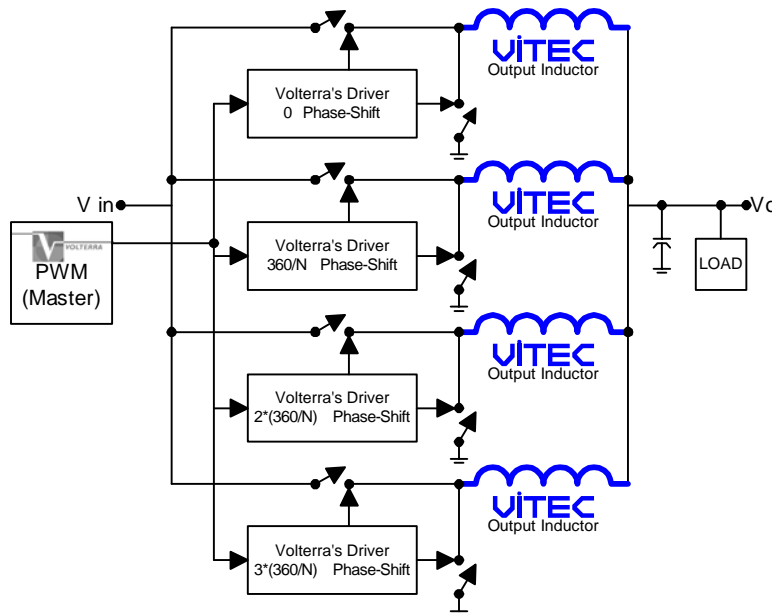

Typical Multi-Phase Application Circuit for a Synchronous Buck Converter

Vitec P/N	Matches Volterra's IC Part Number
59P9002	VT223, VT233 VT1103 Next-Gen ICs
59P9003	VT223, VT233 VT1103 Next-Gen ICs
59P9022	VT222, VT223, VT232, VT233, VT1000, VT1001, VT1102, VT1103.
NOTES	Volterra's VT2xx series is Single-Phase Integrated Synchronous Buck Voltage Regulator Chipset.
	Volterra's VT1xxx series is Multi-Phase Synchronous Buck Voltage Regulator Chipset.

SMD High Frequency Power Inductor

Designed for Advanced Voltage Regulator Modules

PACKAGE

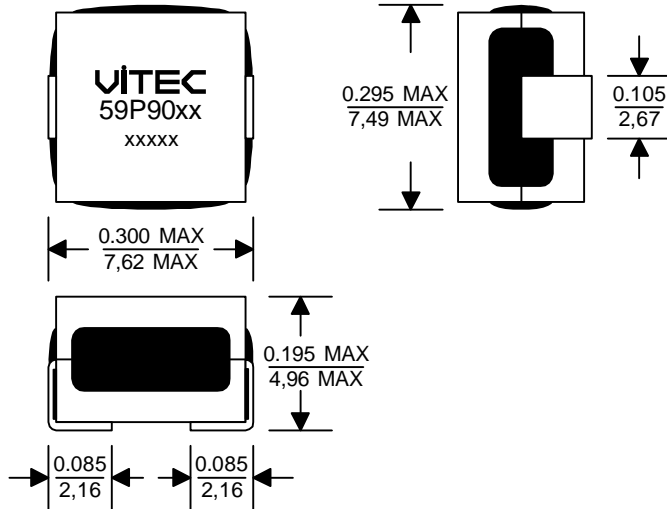

Dimensions: Inches/mm. Tolerances: +/- 0.010"/0,25mm unless otherwise noted

SCHEMATICS

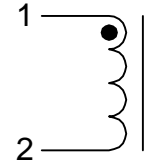

SUGGESTED PCB LAYOUT

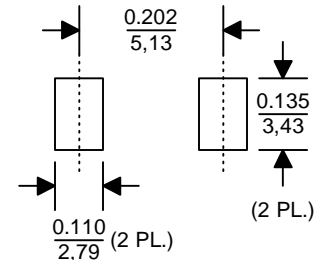

Drawing NOT to scale

ELECTRICAL CHARACTERISTICS @ 25°C (unless otherwise noted)

Part Number		Inductance @ 0Adc ⁴	Inductance @ Irated ⁴	Irated ¹	DCR		Saturation Current ²			Temp. Rise Current ³	Temp. Rise Factor ⁵
Classic	RoHS	nH ± 15%	nH MIN	ADC MAX	mOhm		ADC -40°C	ADC 25°C	ADC 125°C	ADC MAX	
59P9001	59PR9001	32	22	100	0.23	0.30	102	100	95	40	.01369
59P9002	59PR9002	58	39	81	0.23	0.30	83	81	63	40	.02504
59P9003	59PR9003	72	49	65	0.23	0.30	67	65	50	40	.03117
59P9022	59PR9022	100	68	46	0.23	0.30	48	46	35	40	.04334
59P9024	59PR9024	200	136	19	0.23	0.30	21	19	16	40	.08680

Add an "R" to the part number after "P" for the RoHS compliant version (i.e. 59PR9001 is the RoHS compliant version of 59P9001).

Notes:

- The rated current is the saturation current @ 25°C.
- The I(Saturation) is the current at which the inductance drops by 20% maximum of its value at 0ADC. This current is measured at the stated ambient environment and by applying a short duration pulse current to the component, minimizing the self-heating effects.
- The I(Temp. Rise) is the current at which the temperature of the part increases by a maximum of 50°C. This test is performed with the part mounted on a PCB with 0.400" wide, 0.006" thick copper traces and applying the DC current for a minimum of 30 minutes.
- Inductance is measured at 100 KHz and 1.0 Vrms.
- The Temperature Rise can be estimated using the following formulas:

$$\text{Trise (}^{\circ}\text{C)} = \left(\frac{\text{Core Loss} + \text{DCR Loss}}{3.36} \right)^{0.833}$$

$$\text{DCR Loss (mw)} = \left(\text{Idc}^2 + \left(\frac{\Delta I}{2} \right)^2 \right) \times 0.23 \times 1000$$

$$\text{Core Loss} = 0.001749 \times (F)^{1.84} \times (\text{Temp. Rise Factor} \times \Delta I)^{2.28}$$

ΔI = Delta I across the inductor (Amps)

F = Switching frequency (kHz)

IDC = Converter output current (ADC)

SMD High Frequency Power Inductor

Designed for Advanced Voltage Regulator Modules

59P9001 Inductance vs. I_{dc} @ 25°C

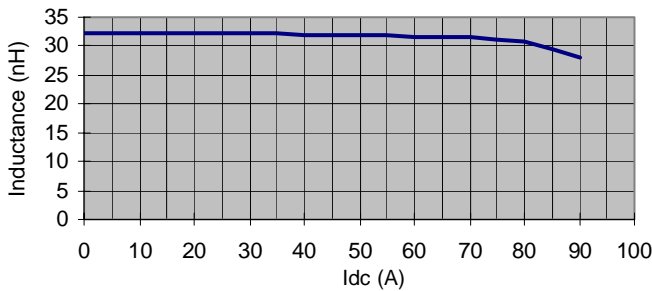

59P9002 Inductance vs. I_{dc} @ 25°C

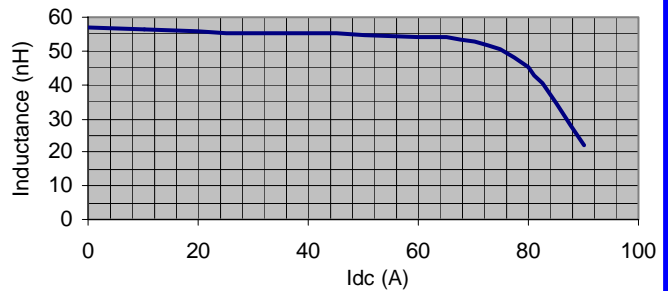

59P9003 Inductance vs. I_{dc} @ 25°C

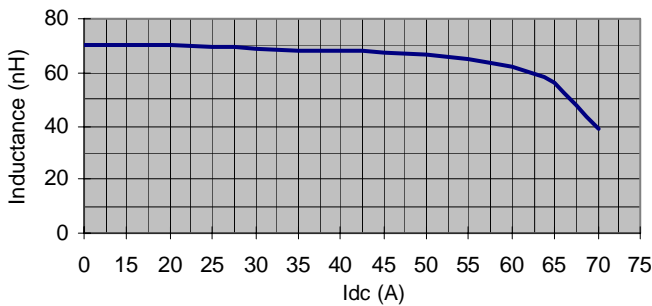

59P9022 Inductance vs. I_{dc} @ 25°C

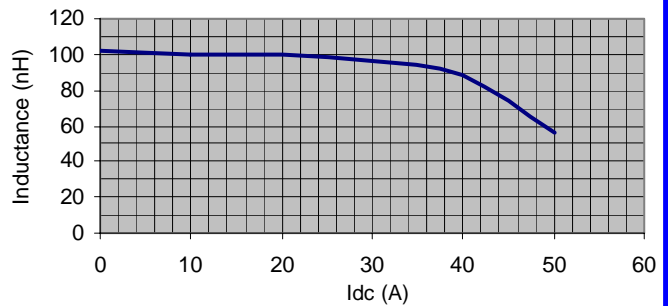

59P9024 Inductance vs. I_{dc} @ 25°C

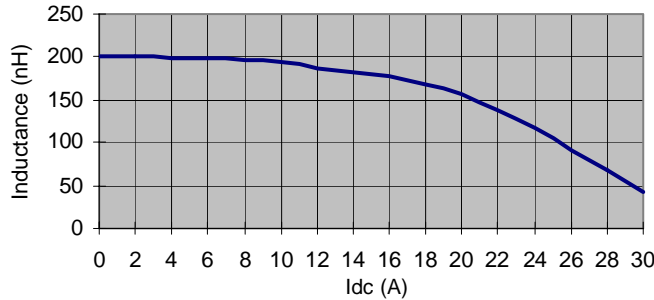

Temperature Rise vs. I_{dc}

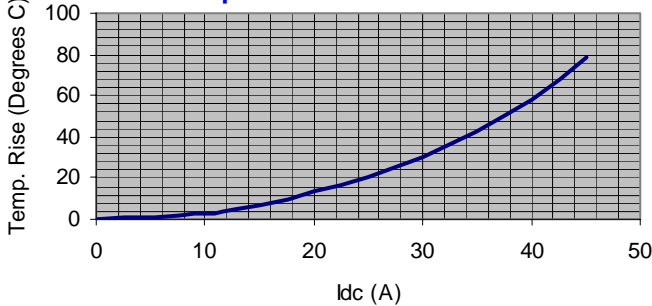

R_{dc} vs. Temperature Rise

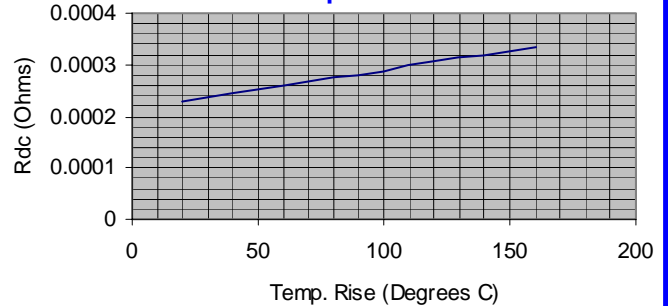

ENVIRONMENTAL & RELIABILITY DATA

Storage Temperature: -40C to +125C
 Operating Temperature: -40C to +125C
 Resistance to Solder Reflow: 3 passes thru. +235C for 30 seconds minimum

Marking permanency: Tested per JESD22-B107-A
 Solderability: Tested per MIL-STD-750D
 Life Test: Tested per MIL-STD-202F, Method 108A
 Thermal Cycle: Tested per JESD22-B104-B, Test Condition G

SMD High Frequency Power Inductor

Designed for Advanced Voltage Regulator Modules

IR Profile

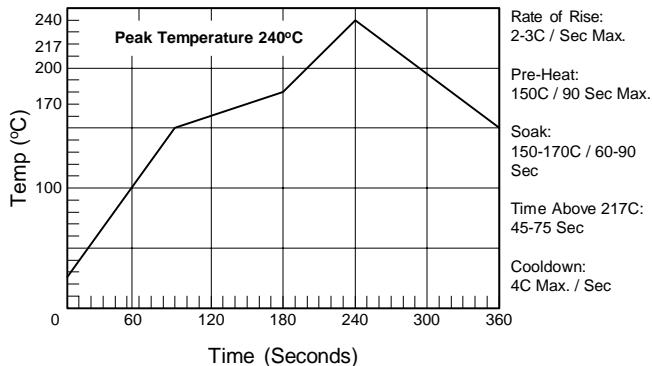

Tape and Reel

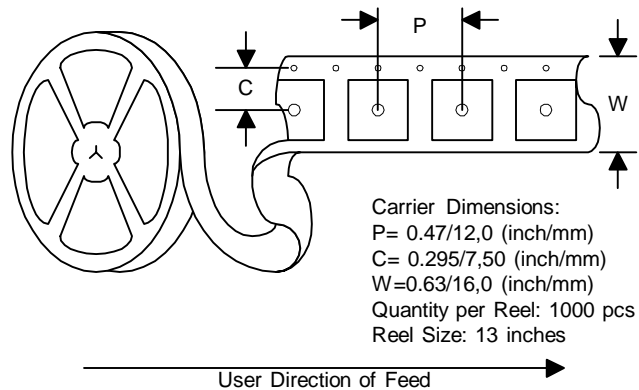

ABOUT US

Vitec Electronics Corporation, founded in 1986, is a worldwide leader in the design, manufacture and sale of magnetic solutions. Vitec's market focus includes the power, power conditioning, telecom, networking, communications and computing. Vitec has also established strong alliances with chip manufacturers whereby magnetic solutions are designed in conjunction with unique silicon requirements and are offered as reference designs by the chip companies.

With its Corporate Headquarters and Research & Development center located in Carlsbad, California, and its state of the art manufacturing facility and material sourcing in China, Vitec is uniquely positioned to supply the latest technology at the lowest cost. Vitec offers both standard and custom product design capabilities with all of its facilities being ISO certified.

QUALITY POLICY

Vitec will provide products and services that meet or exceed our Customer's requirements, conform to company policies and standards, and exhibit continuously improving levels of Quality.

COMMITMENT

VITEC Electronics empowers each of its employees by providing a business environment that encourages a commitment to excellence, a sense of ownership and personal accountability to all Vitec Customers.

Competitive Pricing, Quality Products, and On Time Deliveries are expected from today's World Class Magnetics Suppliers. The high standards of today's customer are strengthening the dedication and commitment of VITEC Electronics to provide Total Customer Service.

CONTACT US

USA

VITEC ELECTRONICS CORPORATION
6213 El Camino Real
Carlsbad, CA 92009
U.S.A.

TEL: +1 (760) 918-8831
FAX: +1 (760) 918-8840

ASIA

SHANGHAI VITEC ELECTRONICS CO., LTD.
3369 He Chuan Road
Min Hang District, Shanghai, 201103
China

TEL: +86 (21) 6446-4828
FAX: +86 (21) 6446-4865

SMD High Frequency Power Inductor

Designed for VRD & VRM 10.x & 11.x Applications

FEATURES

- Recommended for use with all major Voltage Regulator ICs
- High Current handling capability in the smallest footprint & profile
- Up to 2MHz operating frequency
- Extended operating temperature range: -40C to 125C
- Robust SMD package capable of handling the most aggressive SMT assembly process
- RoHS compliant version available

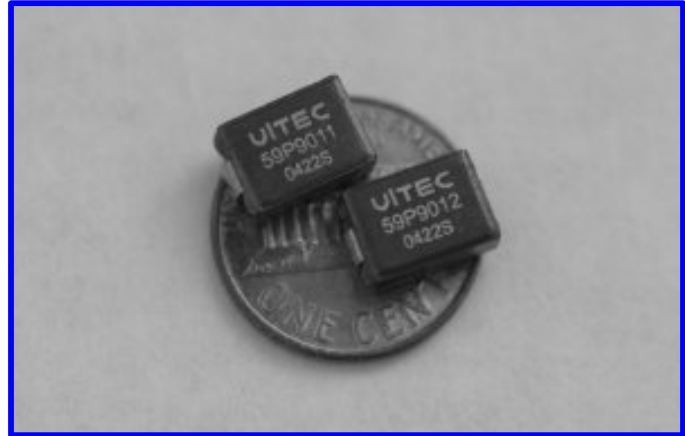

APPLICATIONS

- VRD and VRM 10.x and 11.x based designs
- Multi-Phase Voltage regulator designs
- Server, Desktop, PDA, Graphics cards, Notebook computers, DDR, telecom switches and routers
- DC-DC converters, Battery powered devices, high current power supplies
- High Current NPUs in networking equipment
- Point-of-load Modules

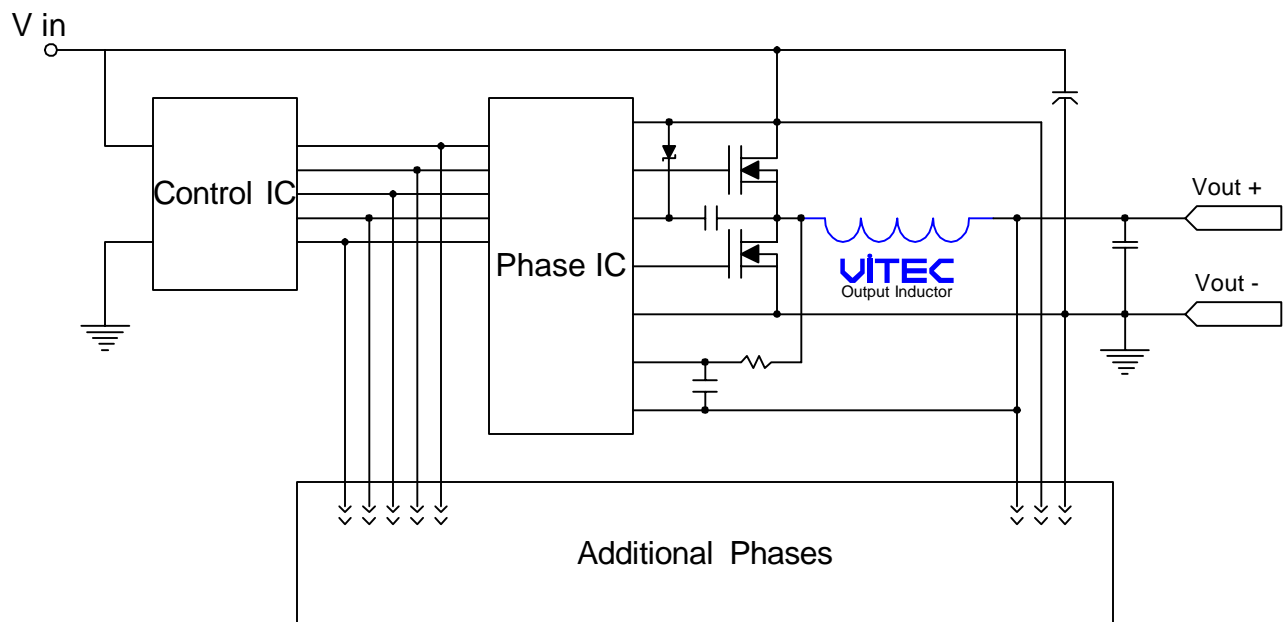

Typical Multi-Phase Application Circuit for a Buck Converter

SMD High Frequency Power Inductor

Designed for VRD & VRM 10.x & 11.x Applications

PACKAGE

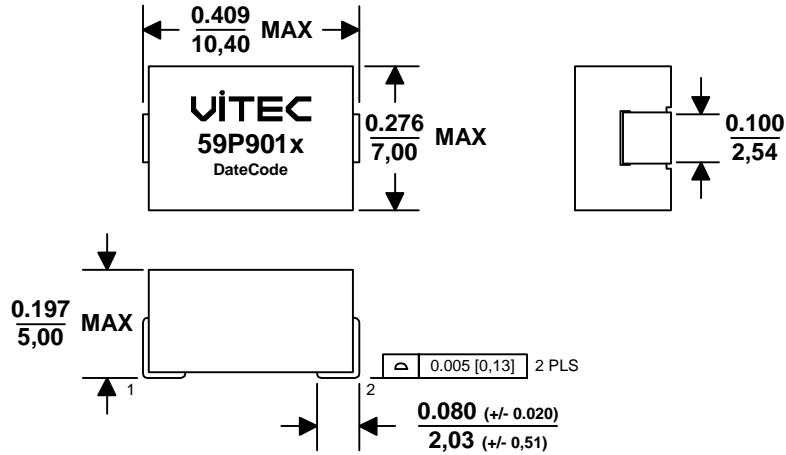

Dimensions: Inches/mm. Tolerances: +/- 0.010"/0,25mm unless otherwise noted

SCHEMATIC

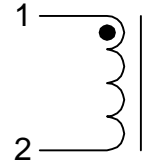

SUGGESTED PCB LAYOUT

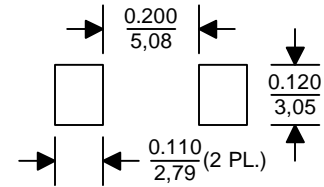

Drawing NOT to scale

ELECTRICAL CHARACTERISTICS @ 25°C (unless otherwise noted)

Part Number		Inductance @ 0Adc ⁴	Inductance @ Irated ⁴	Irated ¹	DCR	Saturation Current ²			Temp. Rise Current ³	Temp. Rise Factor ⁵
Classic	RoHS	nH ± 10%	nH MIN	ADC MAX	mOhm +/- 10%	ADC -40°C	ADC 25°C	ADC 125°C	ADC MAX	
59P9010	59PR9010	90	65	63	0.245	64	63	50	37	0.02631
59P9011	59PR9011	125	90	45	0.245	46	45	36	37	0.03663
59P9012	59PR9012	160	115	35	0.245	36	35	28	37	0.04694
59P9013	59PR9013	210	151	27	0.245	28	27	21	37	0.06165

Add an "R" to the part number after "P" for the RoHS compliant version (i.e. 59PR9011 is the RoHS compliant version of 59P9011).

Notes:

- The rated current is the saturation current @ 25°C.
- The I(Saturation) is the current at which the inductance drops by 20% maximum of its value at 0ADC. This current is measured at the stated ambient environment and by applying a short duration pulse current to the component, minimizing the self-heating effects.
- The I (Temp. Rise) is the current at which the temperature of the part increases by a maximum of 50°C. This test is performed with the part mounted on a PCB with traces having 1.7 times the cross sectional area of the copper leads and applying the DC current for a minimum of 30 minutes.
- Inductance is measured at 100 KHz and 1.0 Vrms.
- Temperature Rise can be estimated using the following formulas:

$$T_{rise} (^{\circ}C) = \left(\frac{\text{Core Loss} + \text{DCR Loss}}{3.06} \right)^{0.833}$$

$$\text{DCR Loss (mW)} = \left(I_{dc}^2 + \left(\frac{\Delta I}{2} \right)^2 \right) \times \text{TYP DCR (mOhms)}$$

$$\text{Core Loss (mW)} = 0.002636 \times (F)^{1.84} \times (\text{Temp. Rise factor} \times \Delta I)^{2.28}$$

IDC = DC output current (ADC)

Δ I = Delta I across the inductor (Amps)

F = Switching frequency (kHz)

SMD High Frequency Power Inductor

Designed for VRD & VRM 10.x & 11.x Applications

59P9010 Inductance vs. I_{dc} @ 25°C

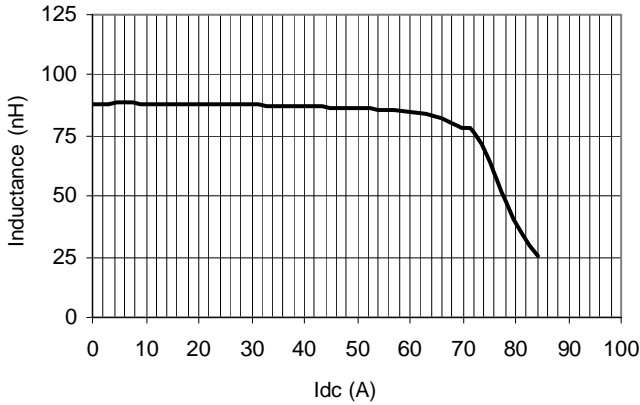

59P9011 Inductance vs. I_{dc} @ 25°C

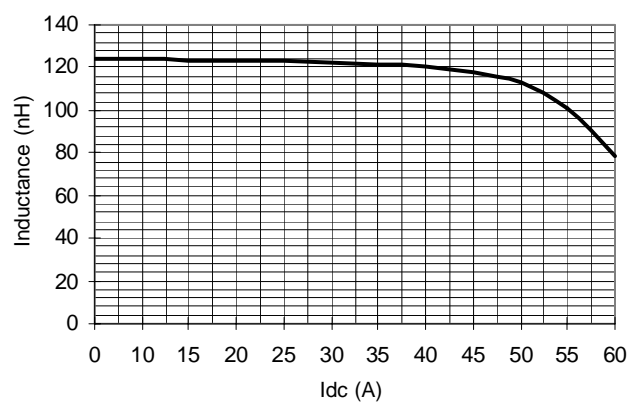

59P9012 Inductance vs. I_{dc} @ 25°C

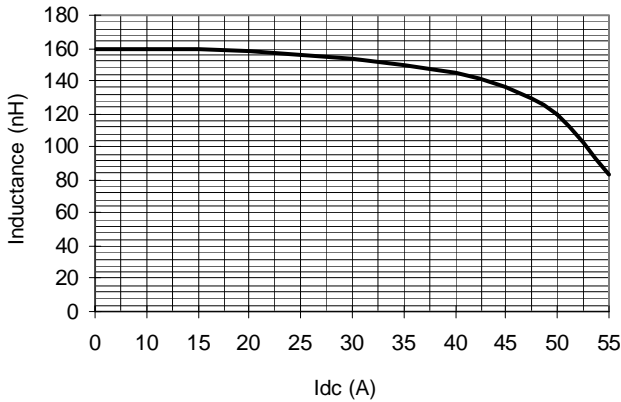

59P9013 Inductance vs. I_{dc} @ 25°C

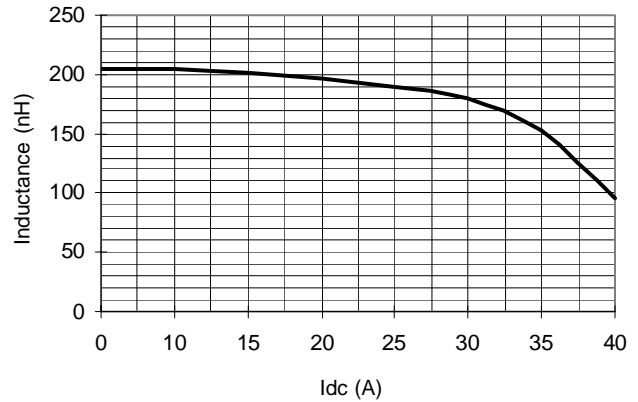

59P901X Temp. Rise vs. I_{dc}

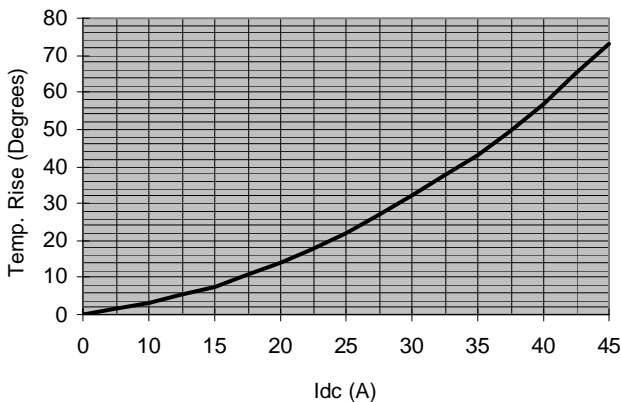

59P901X R_{dc} vs. Temp. Rise

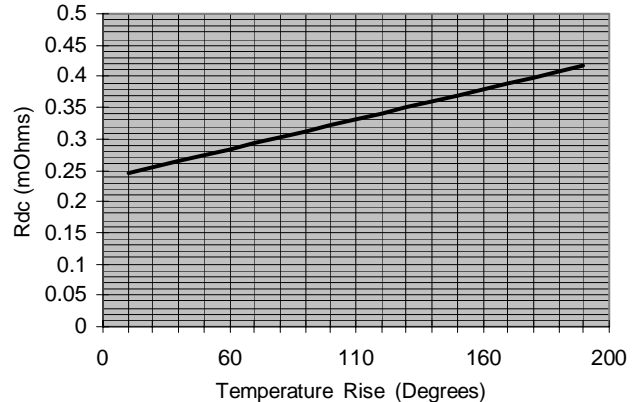

ENVIRONMENTAL & RELIABILITY DATA

Storage Temperature: -40C to +125C
 Operating Temperature: -40C to +125C
 Resistance to Solder Reflow: 3 passes thru. +235C for 30 seconds minimum

Marking permanency: Tested per JESD22-B107-A
 Solderability: Tested per MIL-STD-750D
 Life Test: Tested per MIL-STD-202F, Method 108A
 Thermal Cycle: Tested per JESD22-B104-B, Test Condition G

SMD High Frequency Power Inductor

Designed for VRD & VRM 10.x & 11.x Applications

IR Profile

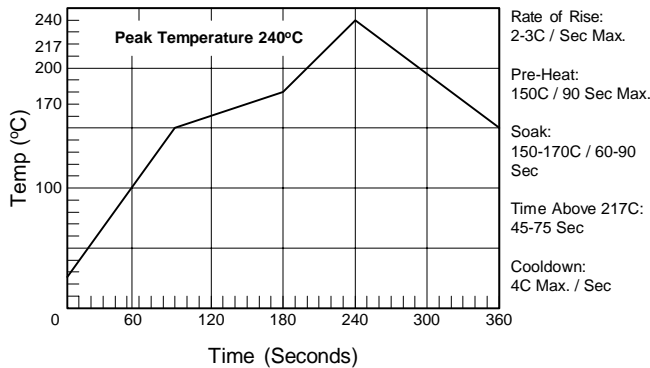

Tape and Reel

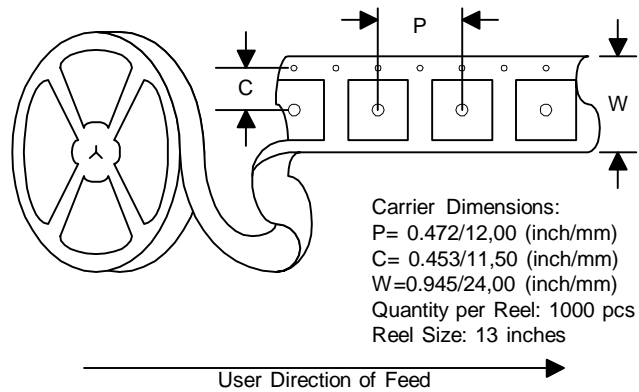

ABOUT US

Vitec Electronics Corporation, founded in 1986, is a worldwide leader in the design, manufacture and sale of magnetic solutions. Vitec's market focus includes the power, power conditioning, telecom, networking, communications and computing. Vitec has also established strong alliances with chip manufacturers whereby magnetic solutions are designed in conjunction with unique silicon requirements and are offered as reference designs by the chip companies.

With its Corporate Headquarters and Research & Development center located in Carlsbad, California, and its state of the art manufacturing facility and material sourcing in China, Vitec is uniquely positioned to supply the latest technology at the lowest cost. Vitec offers both standard and custom product design capabilities with all of its facilities being ISO certified.

QUALITY POLICY

Vitec will provide products and services that meet or exceed our Customer's requirements, conform to company policies and standards, and exhibit continuously improving levels of Quality.

COMMITMENT

VITEC Electronics empowers each of its employees by providing a business environment that encourages a commitment to excellence, a sense of ownership and personal accountability to all Vitec Customers.

Competitive Pricing, Quality Products, and On Time Deliveries are expected from today's World Class Magnetics Suppliers. The high standards of today's customer are strengthening the dedication and commitment of VITEC Electronics to provide Total Customer Service.

CONTACT US

USA

VITEC ELECTRONICS CORPORATION
6213 El Camino Real
Carlsbad, CA 92009
U.S.A.

TEL: +1 (760) 918-8831
FAX: +1 (760) 918-8840

ASIA

SHANGHAI VITEC ELECTRONICS CO., LTD.
3369 He Chuan Road
Min Hang District, Shanghai, 201103
China

TEL: +86 (21) 6446-4828
FAX: +86 (21) 6446-4865

SMD High Frequency Power Inductor

Designed for VRD & VRM 10.x & 11.x Applications

FEATURES

- Recommended for use with all major Voltage Regulator ICs
- High Current handling capability in the smallest footprint & profile
- Up to 2MHz operating frequency
- Extended operating temperature range: -40C to 125C
- Robust SMD package capable of handling the most aggressive SMT assembly process
- RoHS compliant version available

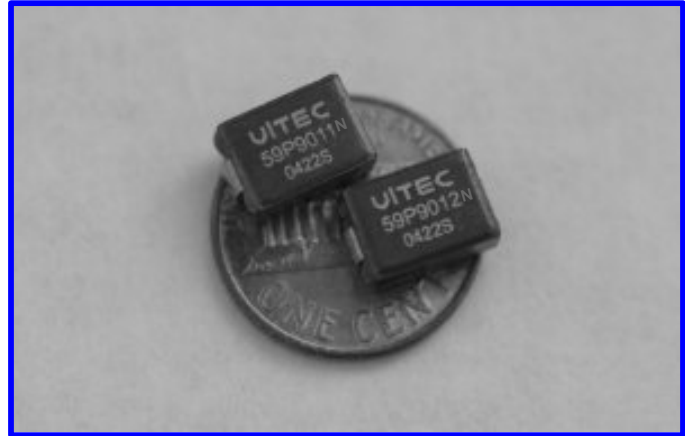

APPLICATIONS

- VRD and VRM 10.x and 11.x based designs
- Multi-Phase Voltage regulator designs
- Server, Desktop, PDA, Graphics cards, Notebook computers, DDR, telecom switches and routers
- DC-DC converters, Battery powered devices, high current power supplies
- High Current NPUs in networking equipment
- Point-of-load Modules
- DCR Sensing

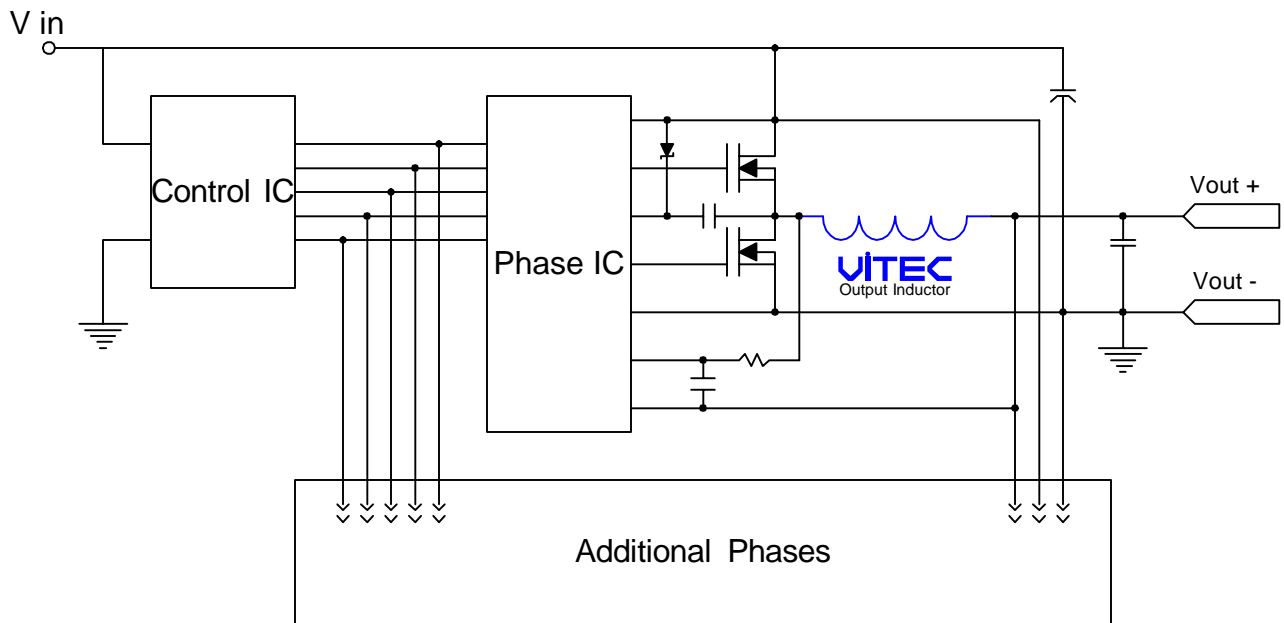

Typical Multi-Phase Application Circuit for a Buck Converter

SMD High Frequency Power Inductor

Designed for VRD & VRM 10.x & 11.x Applications

PACKAGE

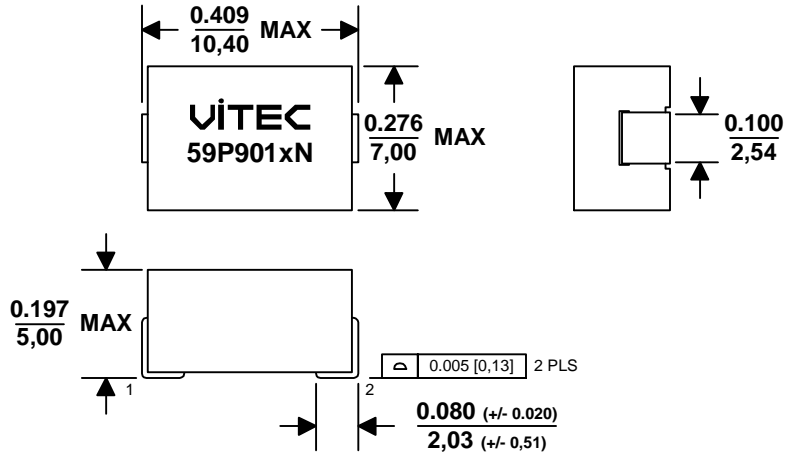

Dimensions: Inches/mm. Tolerances: +/- 0.010"/0,25mm unless otherwise noted

SCHEMATIC

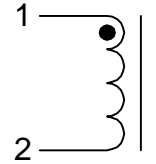

SUGGESTED PCB LAYOUT

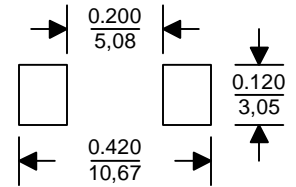

Drawing NOT to scale

ELECTRICAL CHARACTERISTICS @ 25°C (unless otherwise noted)

Part Number		Inductance @ 0Adc ⁴	Inductance @ Irated ⁴	Irated ¹	DCR	Saturation Current ²			Temp. Rise Current ³	Temp. Rise Factor ⁵
Classic	RoHS	nH ± 10%	nH MIN	ADC MAX	mOhm +/- 10%	ADC -40°C	ADC 25°C	ADC 125°C	ADC MAX	
59P9010N	59PR9010N	90	65	63	0.47	64	63	50	27	0.02631
59P9011N	59PR9011N	125	90	45	0.47	46	45	36	27	0.03663
59P9012N	59PR9012N	160	115	35	0.47	36	35	28	27	0.04694
59P9013N	59PR9013N	210	151	27	0.47	28	27	21	27	0.06165

Add an "R" to the part number after "P" for the RoHS compliant version (i.e. 59PR9011N is the RoHS compliant version of 59P9011N).

Notes:

- The rated current is the saturation current @ 25°C.
- The I(Saturation) is the current at which the inductance drops by 20% maximum of its value at 0ADC. This current is measured at the stated ambient environment and by applying a short duration pulse current to the component, minimizing the self-heating effects.
- The I (Temp. Rise) is the current at which the temperature of the part increases by a maximum of 50°C. This test is performed with the part mounted on a PCB with traces having 1.7 times the cross sectional area of the copper leads and applying the DC current for a minimum of 30 minutes.
- Inductance is measured at 100 KHz and 1.0 Vrms.
- Temperature Rise can be estimated using the following formulas:

$$T_{rise} (°C) = \left(\frac{\text{Core Loss} + \text{DCR Loss}}{3.06} \right)^{0.833}$$

$$\text{DCR Loss (mW)} = \left(I_{dc}^2 + \left(\frac{\Delta I}{2} \right)^2 \right) \times \text{TYP DCR (mOhms)}$$

$$\text{Core Loss (mW)} = 0.002636 \times (F)^{1.84} \times (\text{Temp. Rise factor} \times \Delta I)^{2.28}$$

IDC = DC output current (ADC)

Δ I = Delta I across the inductor (Amps)

F = Switching frequency (kHz)

SMD High Frequency Power Inductor

Designed for VRD & VRM 10.x & 11.x Applications

59P9010N Inductance vs. I_{dc} @ 25°C

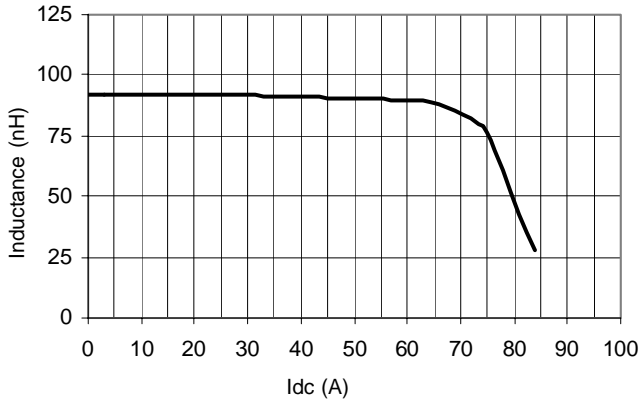

59P9011N Inductance vs. I_{dc} @ 25°C

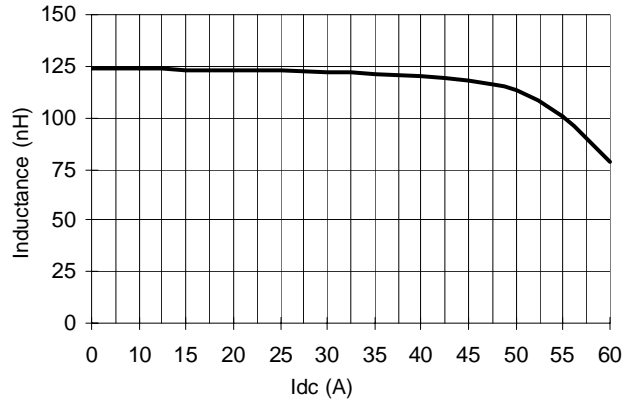

59P9012N Inductance vs. I_{dc} @ 25°C

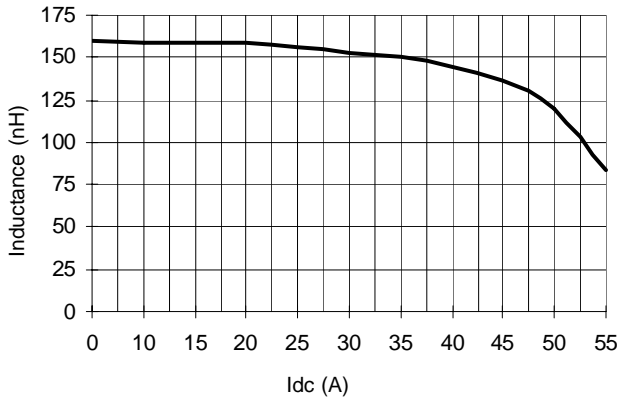

59P9013N Inductance vs. I_{dc} @ 25°C

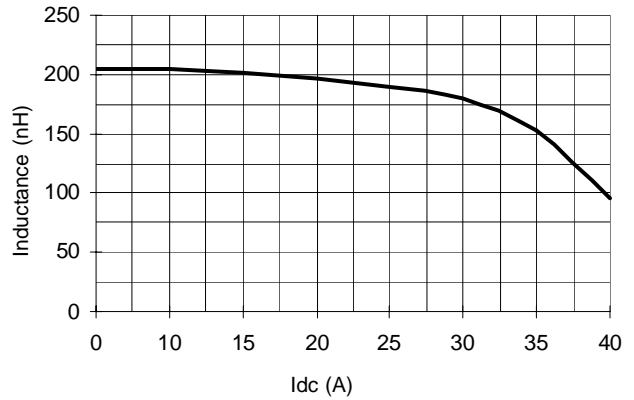

59P901xN Temp. Rise vs. I_{dc}

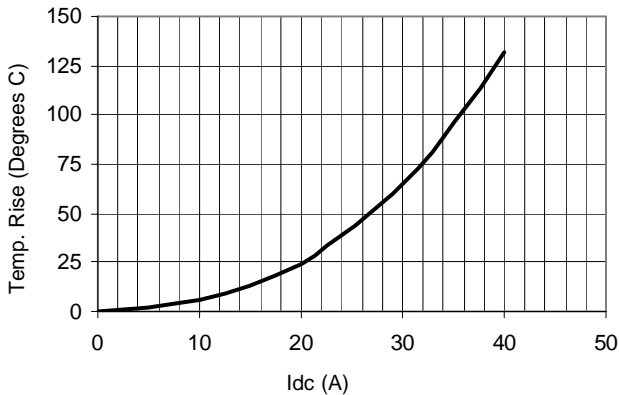

59P901xN R_{dc} vs. Temp. Rise

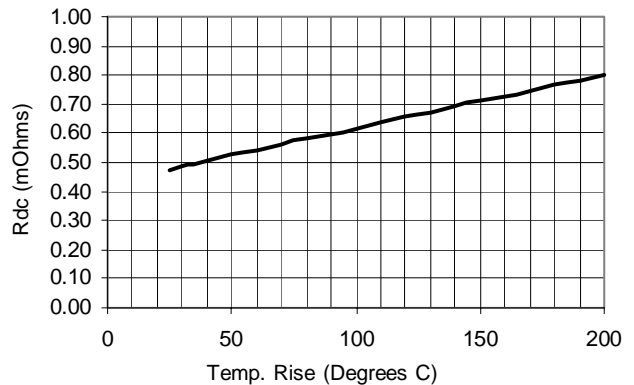

ENVIRONMENTAL & RELIABILITY DATA

Storage Temperature: -40C to +125C
 Operating Temperature: -40C to +125C
 Resistance to Solder Reflow: 3 passes thru. +235C for 30 seconds minimum

Marking permanency: Tested per JESD22-B107-A
 Solderability: Tested per MIL-STD-750D
 Life Test: Tested per MIL-STD-202F, Method 108A
 Thermal Cycle: Tested per JESD22-B104-B, Test Condition G

SMD High Frequency Power Inductor

Designed for VRD & VRM 10.x & 11.x Applications

IR Profile

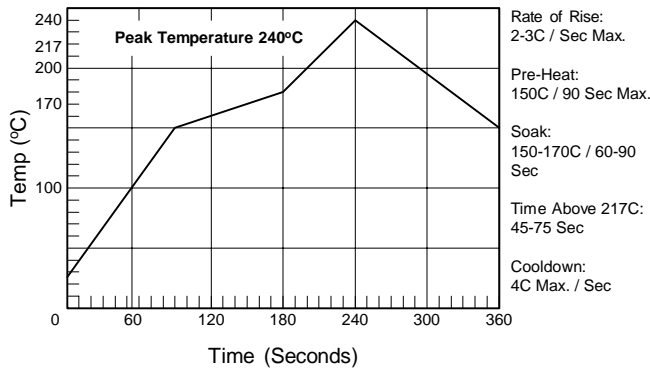

Tape and Reel

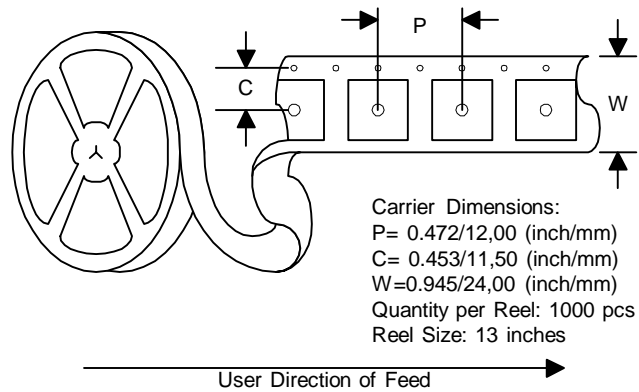

ABOUT US

Vitec Electronics Corporation, founded in 1986, is a worldwide leader in the design, manufacture and sale of magnetic solutions. Vitec's market focus includes the power, power conditioning, telecom, networking, communications and computing. Vitec has also established strong alliances with chip manufacturers whereby magnetic solutions are designed in conjunction with unique silicon requirements and are offered as reference designs by the chip companies.

With its Corporate Headquarters and Research & Development center located in Carlsbad, California, and its state of the art manufacturing facility and material sourcing in China, Vitec is uniquely positioned to supply the latest technology at the lowest cost. Vitec offers both standard and custom product design capabilities with all of its facilities being ISO certified.

QUALITY POLICY

Vitec will provide products and services that meet or exceed our Customer's requirements, conform to company policies and standards, and exhibit continuously improving levels of Quality.

COMMITMENT

VITEC Electronics empowers each of its employees by providing a business environment that encourages a commitment to excellence, a sense of ownership and personal accountability to all Vitec Customers.

Competitive Pricing, Quality Products, and On Time Deliveries are expected from today's World Class Magnetics Suppliers. The high standards of today's customer are strengthening the dedication and commitment of VITEC Electronics to provide Total Customer Service.

CONTACT US

USA

VITEC ELECTRONICS CORPORATION
6213 El Camino Real
Carlsbad, CA 92009
U.S.A.

TEL: +1 (760) 918-8831
FAX: +1 (760) 918-8840

ASIA

SHANGHAI VITEC ELECTRONICS CO., LTD.
3369 He Chuan Road
Min Hang District, Shanghai, 201103
China

TEL: +86 (21) 6446-4828
FAX: +86 (21) 6446-4865

High Freq., High Power Inductor

Designed for VRD & VRM Applications

FEATURES

- Designed for use in VRM 10.X & 11.X Applications.
- Operating Frequency 0.350 - 2.0 MHz.
- Operating Temperature Range of -40°C to 125°C.
- RoHS Compliant Version Available.
- Low DC Resistance for higher efficiency.
- Surface Mount Package for pick and place assembly.

DRAWING

P/N	A
59P9043	0.256 [6.50]
59P9044	0.236 [6.00]
59P22-152	0.232 [5.90]

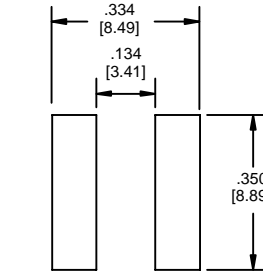
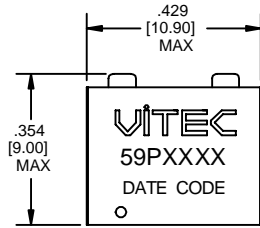

SUGGESTED PCB LAYOUT

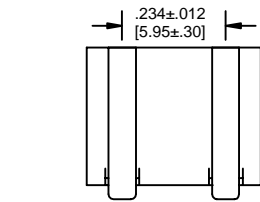
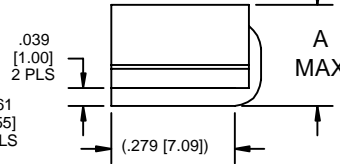
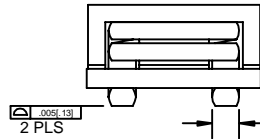

SCHEMATIC

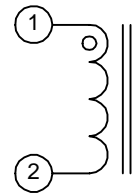

ALL DIMENSIONS GIVEN IN INCHES [MM].
TOLERANCES UNLESS OTHERWISE SPECIFIED.
XX±.01 [X±.25] XX±.004 [XX±.10] ANGULAR: ±1°

ELECTRICAL CHARACTERISTICS @ 25°C

Part Number		Inductance @ 0Adc ⁴	Inductance @ Irated ⁴	Irated ¹	DCR		MAX Saturation Current ²			Temp. Rise Current ³	Temp. Rise Factor ⁵
Classic	RoHS	nH	nH	ADC	mOhms		ADC	ADC	ADC	ADC	
		± 15%	MIN	MAX	TYP	MAX	-40°C	25°C	125°C	MAX	
59P9043	59PR9043	205	140	48	0.54±10%		51	48	36	35	0.03557
59P9044	59PR9044	510	347	29	1.3	1.5	35	29	22	28	0.05889
59P22-152	59PR22-152	1500	1020	13	3.0	3.5	13.5	13	10	18.5	0.13138

Add an "R" to the part number after "P" for the RoHS compliant version (i.e. 59PR9043 is the RoHS compliant version of 59P9043).

Notes:

- 1 - The rated current is the saturation current @ 25°C.
- 2 - The I(Saturation) is the current at which the inductance drops by 20% maximum of its value at 0ADC. This current is measured at the stated ambient environment and by applying a short duration pulse current to the component, minimizing the self-heating effects.
- 3 - The I(Temp. Rise) is the current at which the temperature of the part increases by a maximum of 50°C. This test is performed with the part mounted on a PCB with 0.250" wide, 0.004" thick copper traces and applying the DC current for a minimum of 30 minutes.
- 4 - Inductance is measured at 100 KHz and 1.0 Vrms.
- 5 - The additional Temperature Rise due to High ET (Voltage x Time) can be estimated using the following formula:

$$\text{Trise (}^\circ\text{C)} = \left(\frac{\text{Core Loss} + \text{DCR Loss}}{5.59} \right)^{0.833}$$

$$\text{DCR Loss} = \left(I_{dc}^2 + \left(\frac{\Delta I}{2} \right)^2 \right) \times \text{TYP DCR}$$

$$\text{Core Loss} = 0.002648 \times (F)^{1.84} \times (\text{Temp. Rise Factor} \times \Delta I)^{2.28}$$

ΔI = Delta I across the inductor
 F = Switching Frequency (kHz)

This drawing is the property of Vitec Electronics Corporation. It is not a controlled document. Therefore it is subject to change without prior notice. Its intended use is to supply preliminary information only. Duplication of all or any part of this drawing is prohibited.

This page intentionally left blank

SMD High Frequency Power Inductor

Designed for VRD & VRM 10.x & 11.x Applications

FEATURES

- Recommended for use with all major Voltage Regulator ICs
- High Current handling capability in the smallest footprint
- Up to 2MHz operating frequency
- Extended operating temperature range: -40°C to 125°C
- Robust SMD package capable of handling the most aggressive SMT assembly process
- RoHS compliant version available
- 100% tested to an 8% DCR tolerance



APPLICATIONS

- VRD and VRM 10.x and 11.x based designs
- Multi-Phase Voltage regulator designs
- Server, Desktop, PDA, Graphics cards, Notebook computers, DDR, telecom switches and routers
- DC-DC converters, Battery powered devices, high current power supplies
- High Current NPUs in networking equipment
- Point-of-load Modules
- DCR sensing

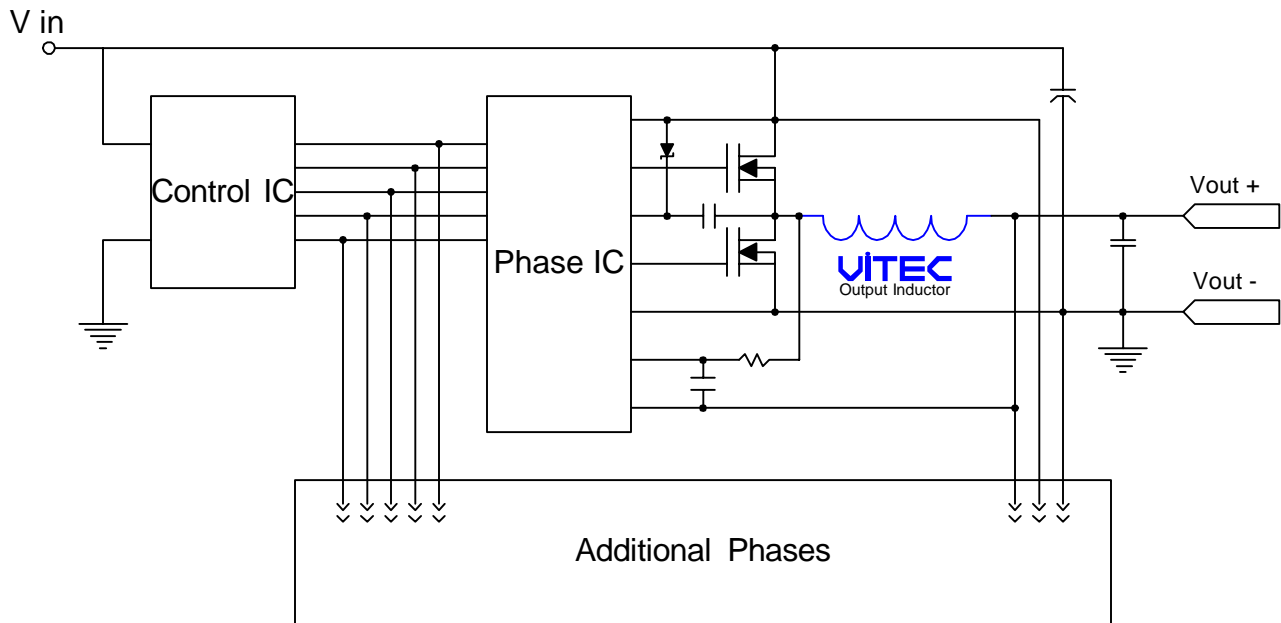

Typical Multi-Phase Application Circuit for a Buck Converter

SMD High Frequency Power Inductor

Designed for VRD & VRM 10.x & 11.x Applications

PACKAGE

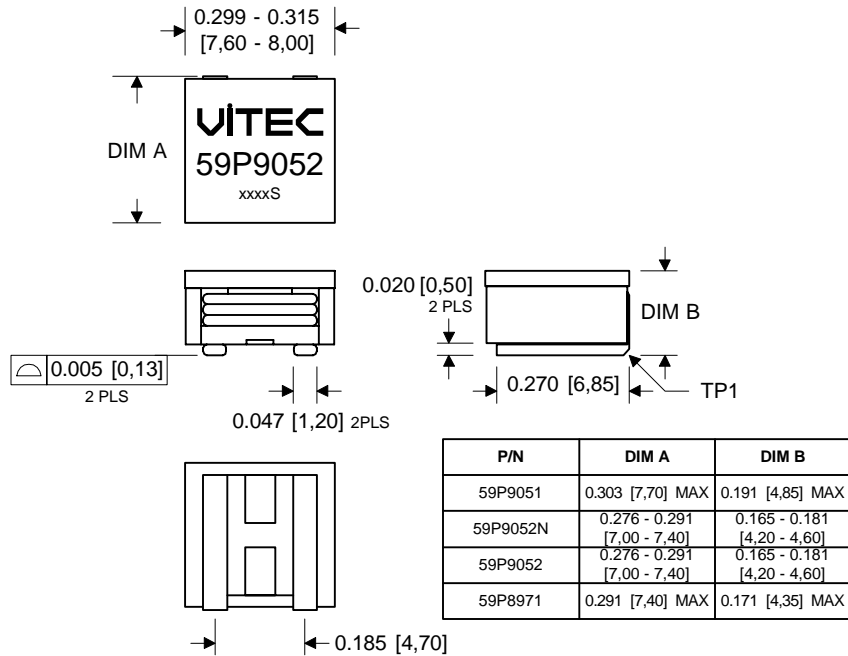

Dimensions: Inches [mm]. Tolerances: +/- 0.005" [0,13mm] unless otherwise noted

SCHEMATIC

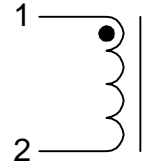

SUGGESTED PCB LAYOUT

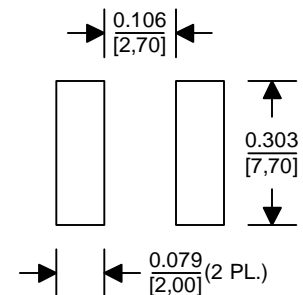

Drawing NOT to scale

ELECTRICAL CHARACTERISTICS @ 25°C (unless otherwise noted)

Part Number		Inductance @ 0Adc ⁴	Inductance @ Isat ^{2,4}	DCR ⁵	Isat ² MAX Saturation Current			Temp. Rise Current ³	Temp. Rise Factor A (TRF A) ⁶	Temp. Rise Factor B (TRF B) ⁶	Temp. Rise Factor C (TRF C) ⁶
Classic	RoHS	nH ± 10%	nH MIN	mOhm +/- 8%	ADC 25°C	ADC 100°C	ADC 125°C	ADC MAX			
59P9051	59PR9051	200	144	0.78	32	25	23	35	8.72	0.001283	0.04289
59P9052N	59PR9052N	300	216	1.48	30	26	24	22	6.54	0.001311	0.04823
59P9052	59PR9052	490	352	1.48	20	16	15	22	6.54	0.001282	0.07883
59P8971	59PR8971	1200	864	4.00	14	11.5	10.5	13	6.17	0.001285	0.11593

Add an "R" to the part number after "P" for the RoHS compliant version (i.e. 59PR9052 is the RoHS compliant version of 59P9052).

- The Rated Current (I_{rated}) is either the Saturation Current at 25°C or the Temperature Rise Current; the lowest number of the two specified currents.
- The Saturation Current (Isat) is the current at which the Inductance drops by a maximum of 20% below the lower limit of its value specified at 0 ADC Bias. Inductance at Isat is measured at the specified Ambient Temperature by applying DC Bias by a short period of time to minimize the self-heating effect of the component.
- The Temperature Rise Current is the current at which the temperature of the part increases by 50°C. This test is performed with the part mounted on a PCB with traces having 1.75 times the cross sectional area of the copper leads of the part. The temperature of the part is measured after applying the DC current for a minimum of 10 minutes.
- Inductance is measured at 100 KHz and 1.0 Vrms.
- DCR is measured from lead to lead at test point TP1.
- Temperature Rise can be estimated using the following formulas:

$$T_{rise} (^{\circ}C) = \left(\frac{\text{Core Loss} + \text{DCR Loss}}{\text{TRF A}} \right)^{0.833}$$

$$\text{DCR Loss (mW)} = \left(I_{dc}^2 + \left(\frac{\Delta I}{2} \right)^2 \right) \times \text{TYP DCR (mOhms)}$$

$$\text{Core Loss (mW)} = \text{TRF B} \times (F)^{1.84} \times (\text{TRF C} \times \Delta I)^{2.28}$$

IDC = DC output current (ADC)

ΔI = Delta I across the inductor (Amps)

F = Switching frequency (kHz)

SMD High Frequency Power Inductor

Designed for VRD & VRM 10.x & 11.x Applications

59P9051 Inductance vs. Idc

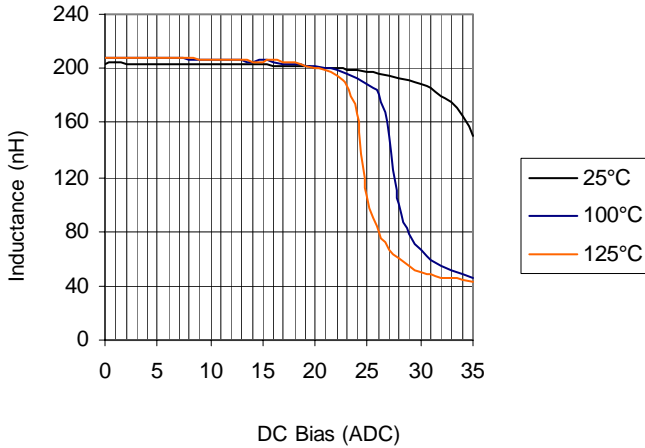

59P9052N Inductance vs. Idc

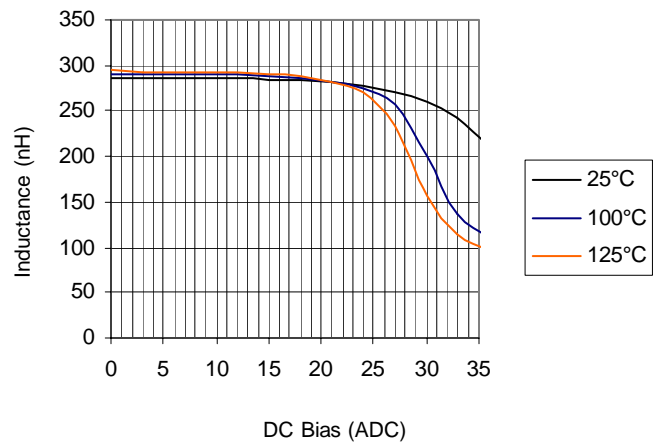

59P9051 Temp. Rise vs. Idc

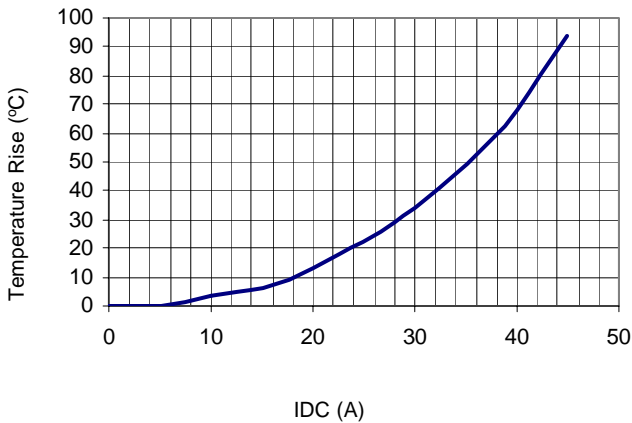

59P9052N Temp. Rise vs. Idc

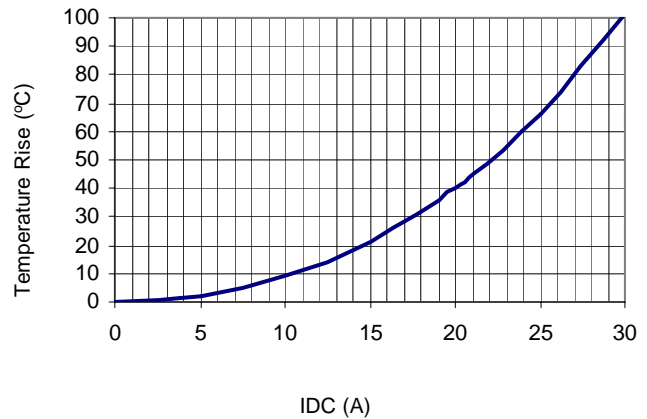

59P9051 Rdc vs. Temp. Rise

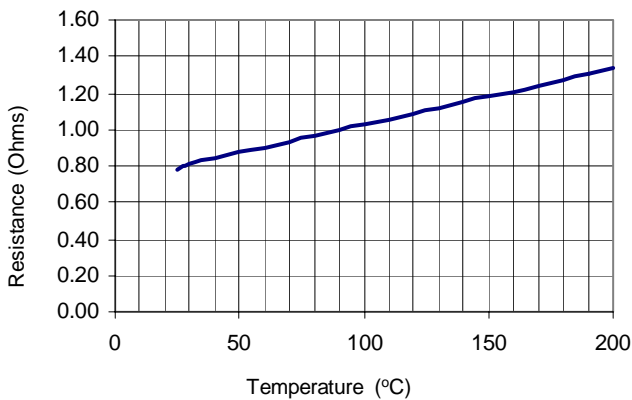

59P9052N Rdc vs. Temp. Rise

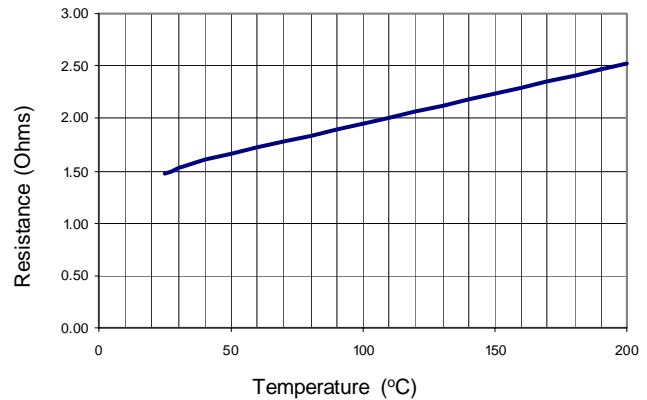

SMD High Frequency Power Inductor

Designed for VRD & VRM 10.x & 11.x Applications

59P9052 Inductance vs. Idc

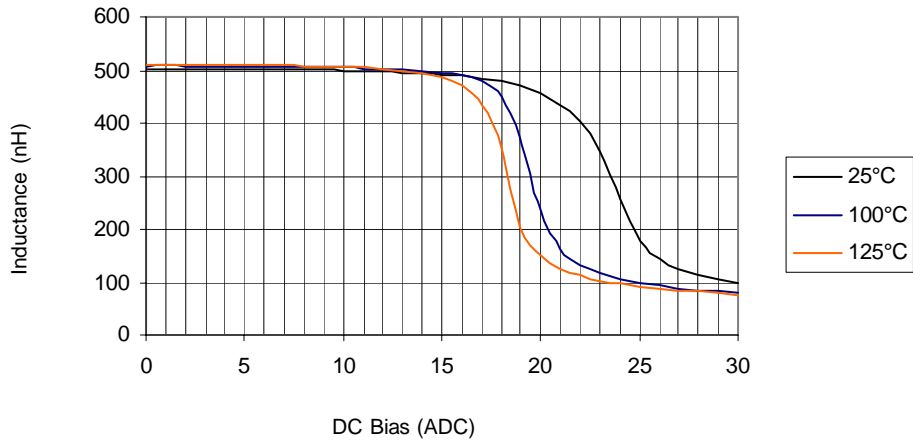

59P9052 Temp. Rise vs. Idc

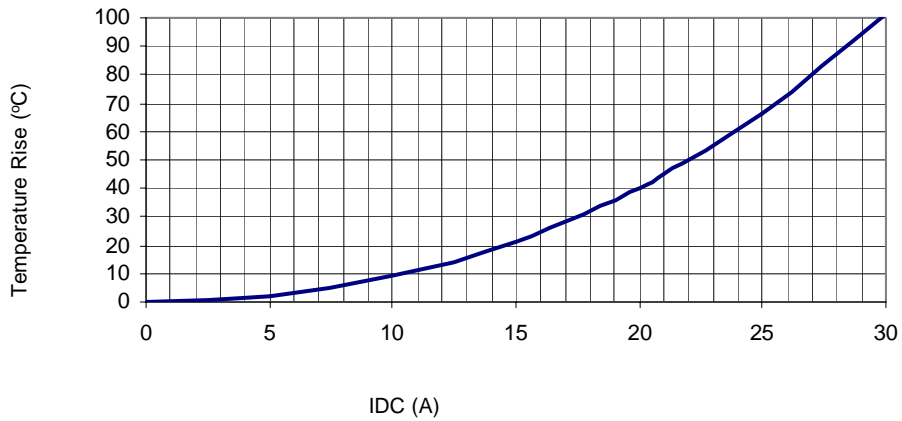

59P9052 Rdc vs. Temp. Rise

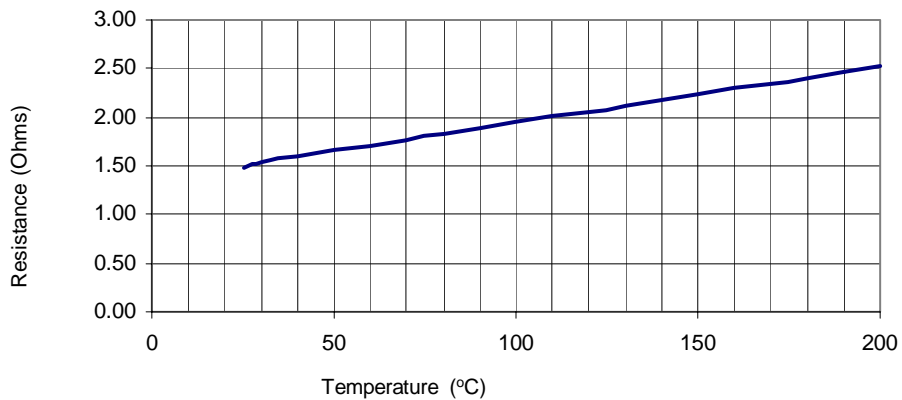

SMD High Frequency Power Inductor

Designed for VRD & VRM 10.x & 11.x Applications

59P8971 Inductance vs. Idc

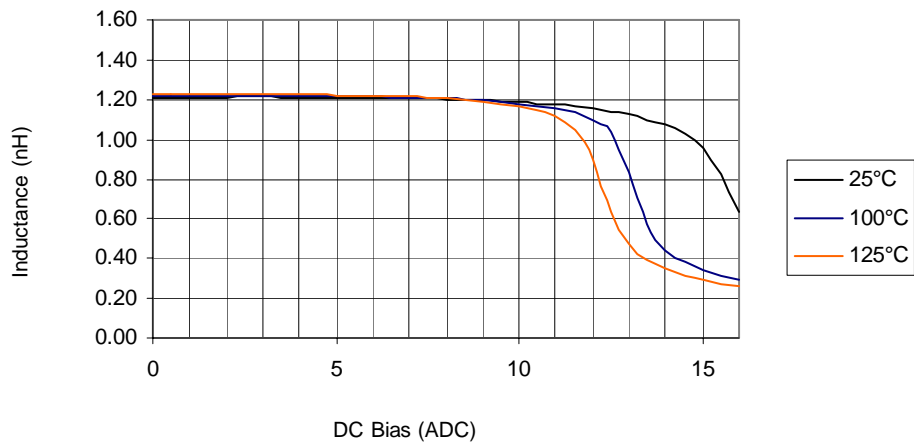

59P8971 Temp. Rise vs. Idc

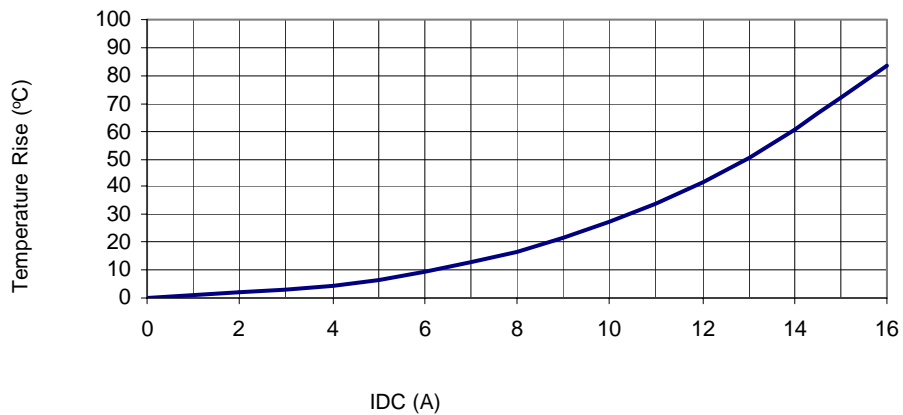

59P8971 Rdc vs. Temp. Rise

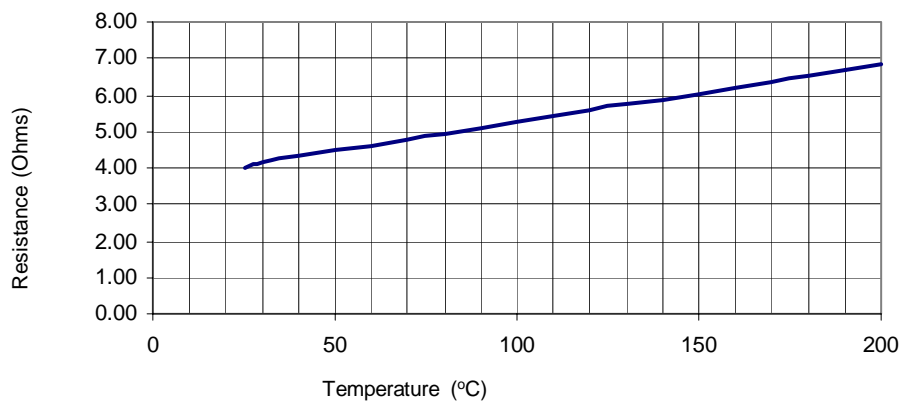

SMD High Frequency Power Inductor

Designed for VRD & VRM 10.x & 11.x Applications

IR Profile

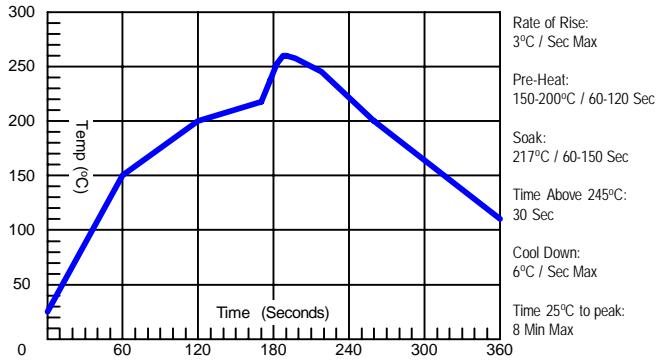

Tape and Reel

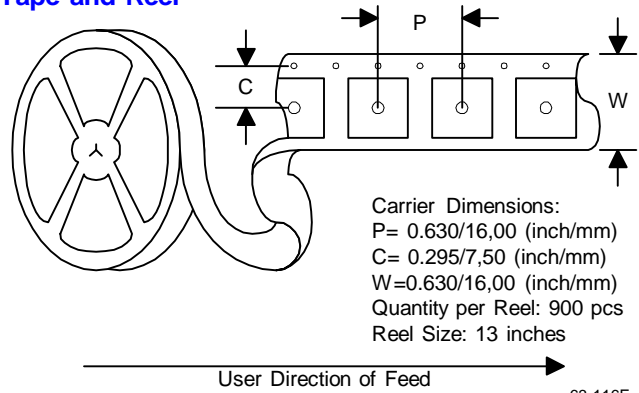

ENVIRONMENTAL & RELIABILITY DATA

Storage Temperature: -40C to +125C
Operating Temperature: -40C to +125C
Resistance to Solder Reflow: 3 passes thru. +235C for 30 seconds minimum

Marking permanency: Tested per JESD22-B107-A
Solderability: Tested per MIL-STD-750D
Life Test: Tested per MIL-STD-202F, Method 108A
Thermal Cycle: Tested per JESD22-B104-B, Test Condition G

ABOUT US

Vitec Electronics Corporation, founded in 1986, is a worldwide leader in the design, manufacture and sale of magnetic solutions. Vitec's market focus includes the power, power conditioning, telecom, networking, communications and computing. Vitec has also established strong alliances with chip manufacturers whereby magnetic solutions are designed in conjunction with unique silicon requirements and are offered as reference designs by the chip companies.

With its Corporate Headquarters and Research & Development center located in Carlsbad, California, and its state of the art manufacturing facility and material sourcing in China, Vitec is uniquely positioned to supply the latest technology at the lowest cost. Vitec offers both standard and custom product design capabilities with all of its facilities being ISO certified.

QUALITY POLICY

Vitec will provide products and services that meet or exceed our Customer's requirements, conform to company policies and standards, and exhibit continuously improving levels of Quality.

COMMITMENT

VITEC Electronics empowers each of its employees by providing a business environment that encourages a commitment to excellence, a sense of ownership and personal accountability to all Vitec Customers.

Competitive Pricing, Quality Products, and On Time Deliveries are expected from today's World Class Magnetics Suppliers. The high standards of today's customer are strengthening the dedication and commitment of VITEC Electronics to provide Total Customer Service.

CONTACT US

USA

VITEC ELECTRONICS CORPORATION
6213 El Camino Real
Carlsbad, CA 92009
U.S.A.

TEL: +1 (760) 918-8831
FAX: +1 (760) 918-8840

ASIA

SHANGHAI VITEC ELECTRONICS CO., LTD.
3369 He Chuan Road
Min Hang District, Shanghai, 201103
China

TEL: +86 (21) 6446-4828
FAX: +86 (21) 6446-4865

Hi-Frequency, Hi-Density SMD Power Inductor

59P907X

FEATURES

- Designed for use with Buck Regulators
- Operating Frequency of 0.250 - 2.0 MHz.
- Low DC Resistance.
- Operating Temperature Range of -40°C to 125°C.
- Surface Mount Package for pick and place assembly.
- Suitable for vapor phase and IR reflow soldering.

DRAWING

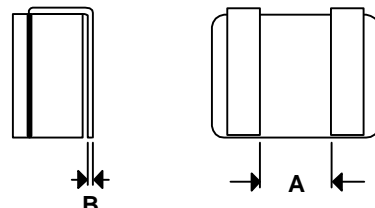
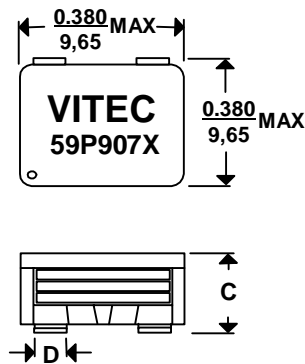

59P9071	
	Inch mm
A	.120 3,05
B	.016 0,41
C	.100 2,54
D	.090 2,29

59P9073 AF4363	
	Inch mm
A	.150 3,81
B	.020 0,51
C	.150 3,81
D	.070 1,78

SCHEMATIC

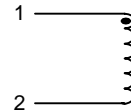

SUGGESTED PCB LAYOUT

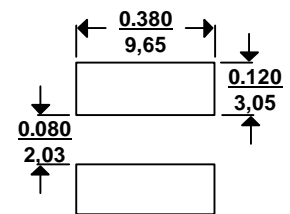

Drawing NOT to scale

Drawing NOT to scale.
Dimensions Inches/mm ± 0.010"/0,25mm unless noted.

ELECTRICAL CHARACTERISTICS @ 25°C

Part Number		Inductance ¹ @ 0Adc ⁴	Inductance ¹ @ Irated ⁴	Irated ¹	DCR		Saturation Current ²			Temp. Rise Current ³	Temp. Rise Factor ⁵	
Classic	RoHS	nH ± 10%	nH MIN	ADC MAX	mOhms TYP MAX		ADC -40°C	ADC 25°C	ADC 125°C	ADC MAX	A	B
59P9071	59PR9071	100	72	35	.49	.53	37	35	26	29	0.04724	3.76
59P9073	59PR9073	100	72	50	.26	.32	46	44	35	38	0.03796	3.43

Add an "R" to the part number after "P" for the RoHS compliant version (i.e. 59PR9071 is the RoHS compliant version of 59P9071).

Notes:

- 1 - The rated current is the saturation current @ 25°C.
- 2 - The I(Saturation) is the current at which the inductance drops by 20% maximum of its value at 0ADC. This current is measured at the stated ambient environment and by applying a short duration pulse current to the component, minimizing the self-heating effects.
- 3 - The I(Temp. Rise) is the current at which the temperature of the part increases by a maximum of 50°C. This test is performed with the part mounted on a PCB with 0.250" wide, 0.004" thick copper traces and applying the DC current for a minimum of 30 minutes.
- 4 - Inductance is measured at 100 KHz and 1.0 Vrms.
- 5 - The additional Temperature Rise due to High ET (Voltage x Time) can be estimated using the following formula:

$$\text{Trise (}^{\circ}\text{C)} = \left(\frac{\text{Core Loss} + \text{DCR Loss}}{B} \right)^{0.833}$$

$$\text{DCR Loss} = \left(I_{dc}^2 + \left(\frac{\Delta I}{2} \right)^2 \right) \times (\text{TYP DCR})$$

$$\text{Core Loss} = 0.00224 \times (F)^{1.84} \times (\text{Temp. Rise Factor A} \times \Delta I)^{2.28}$$

ΔI = Delta I across the inductor
 F = Switching Frequency (kHz)

This drawing is the property of Vitec Electronics Corporation. It is not a controlled document. Therefore it is subject to change without prior notice. Its intended use is to supply preliminary information only. Duplication of all or any part of this drawing is prohibited.

AF3541 092106

This page intentionally left blank

High Frequency SMD Power Inductors

Designed for VRD & VRM Applications

FEATURES

- High Current Handling Capability in the Smallest Footprint & Profile.
- Operating Frequency: 0.2 - 1.8 MHz.
- Operating Temperature Range of -40°C to 125°C.

MECHANICAL

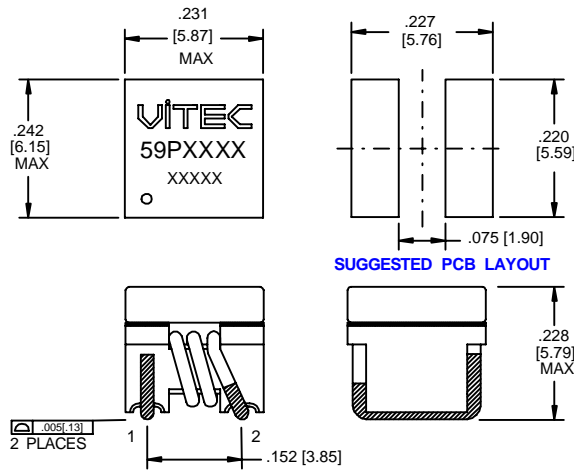

SCHEMATIC

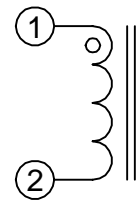

ALL DIMENSIONS GIVEN IN INCHES [MM].
TOLERANCES UNLESS OTHERWISE SPECIFIED.
LINEAR: .XX±.01 [X±.25] .XXX±.005 [XX±.13]
ANGULAR: ±1°

ELECTRICAL CHARACTERISTICS @ 25°C

Part Number		Inductance @ 0Adc ⁴	Inductance @ Irated ⁴	Irated ¹	DCR		Saturation Current ²			Temp. Rise Current ³	Temp. ⁵ Rise Factor	
Classic	RoHS	nH ± 15%	nH MIN	ADC MAX	mOhm		ADC -40°C	ADC 25°C	ADC 125°C	ADC MAX	A	B
59P8970	59PR8970	1200	816	10	6.0	7.0	10.5	10	8	9	0.17343	4.44
59P9091	59PR9091	500	340	17	3.5	4.0	18.5	18	14	13	0.09635	5.40
59P8972	59PR8972	400	272	20	3.0	3.5	23.5	23	18	15	0.07663	6.16
59P9090	59PR9090	215	146	27	1.4	1.8	29	28	23	21	0.06187	5.64

Add an "R" to the part number after "P" for the RoHS compliant version (i.e. 59PR8970 is the RoHS compliant version of 59P8970).

Notes:

- 1 - The rated current is the saturation current @ 25°C.
- 2 - The I(Saturation) is the current at which the inductance drops by 20% maximum of its value at 0ADC. This current is measured at the stated ambient environment and by applying a short duration pulse current to the component, minimizing the self-heating effects.
- 3 - The I(Temp. Rise) is the current at which the temperature of the part increases by a maximum of 50°C. This test is performed with the part mounted on a PCB with 0.250" wide, 0.004" thick copper traces and applying the DC current for a minimum of 30 minutes.
- 4 - Inductance is measured at 100 KHz and 1.0 Vrms.
- 5 - The additional Temperature Rise due to High ET (Voltage x Time) can be estimated using the following formula:

$$\text{Trise (}^{\circ}\text{C)} = \left(\frac{\text{Core Loss} + \text{DCR Loss}}{B} \right)^{0.833}$$

$$\text{DCR Loss} = \left(I_{dc}^2 + \left(\frac{\Delta I}{2} \right)^2 \right) (\text{TYP DCR})$$

$$\text{Core Loss} = 0.00125 \times (F)^{1.84} \times (\text{Temp. Rise Factor A} \times \Delta I)^{2.2}$$

ΔI = Delta I across the inductor
 F = Switching Frequency (kHz)

This drawing is the property of Vitec Electronics Corporation. It is not a controlled document. Therefore it is subject to change without prior notice. Its intended use is to supply preliminary information only. Duplication of all or any part of this drawing is prohibited.

AF4256, AF4304A, AF4315-17 092106

This page intentionally left blank

Multi-Phase SMD Coupled Inductor

Designed for Advanced Voltage Regulator Modules

FEATURES

- Designed for use with Volterra Semiconductor's 4th generation synchronous buck voltage regulator chipsets.
- Lowest output ripple current with less output capacitors.
- Up to 2MHz operating frequency.
- Extended operating temperature range: -40°C to 125°C.
- Robust SMD package capable of handling the most aggressive SMT assembly process.
- US Patent Number 6,362,986.
- RoHS Compliant Version Available.
- Faster transient response and higher efficiency.

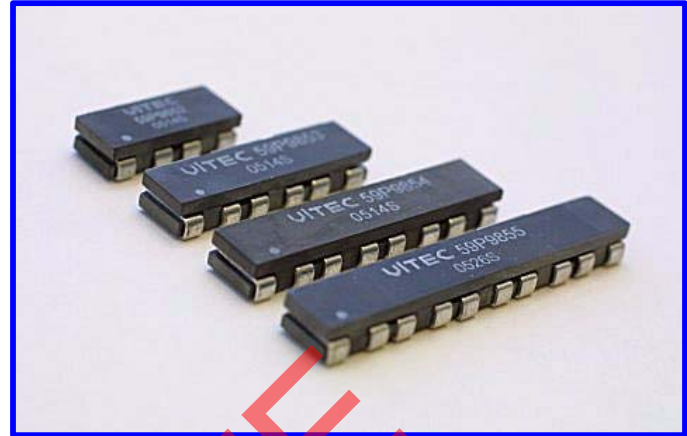

APPLICATIONS

- VRD and VRM 10.x and 11.x based designs
- Multi-Phase Switching regulator designs using Volterra VT1105M®, VT1115M® chipsets only
- Server, Desktop, Graphics cards, Notebook computers, DDR, telecom switches and routers

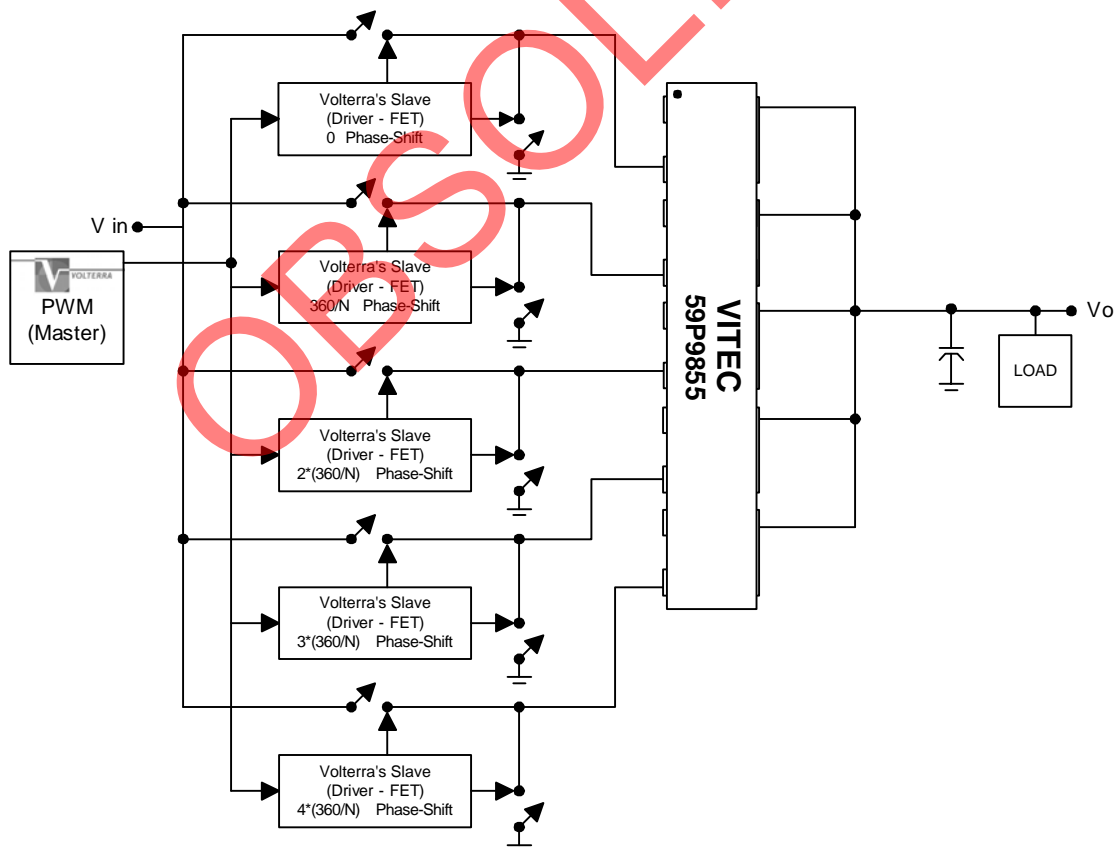

Typical Multi-Phase Application Circuit for a Synchronous Buck Converter

Multi-Phase SMD Coupled Inductor

Designed for Advanced Voltage Regulator Modules

PACKAGE

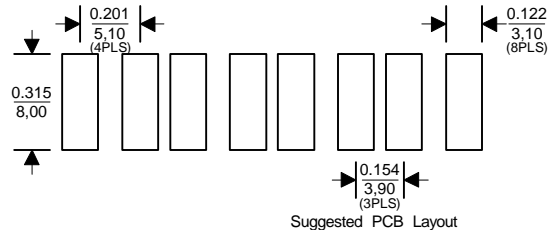
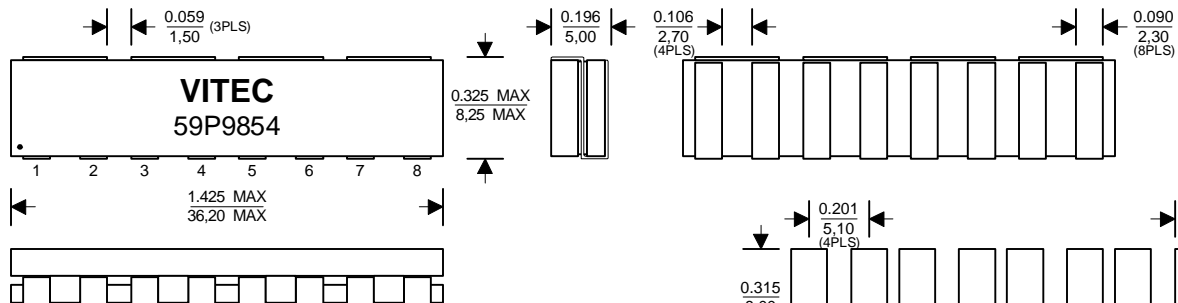
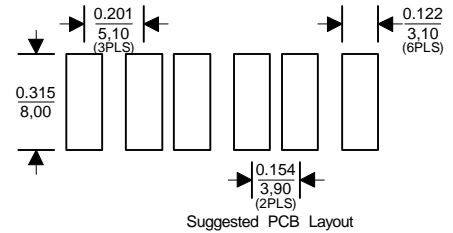
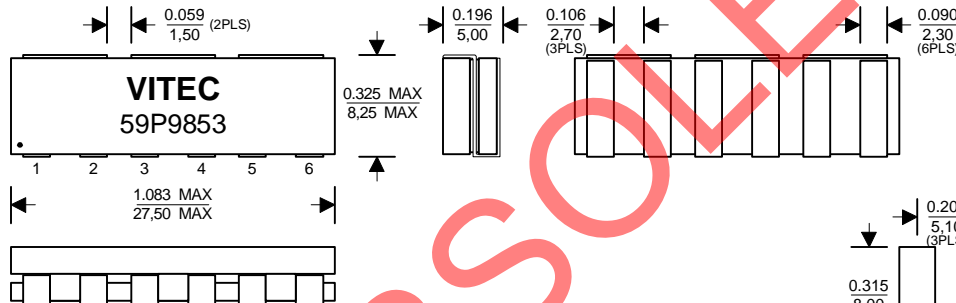
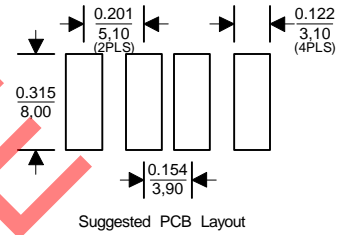
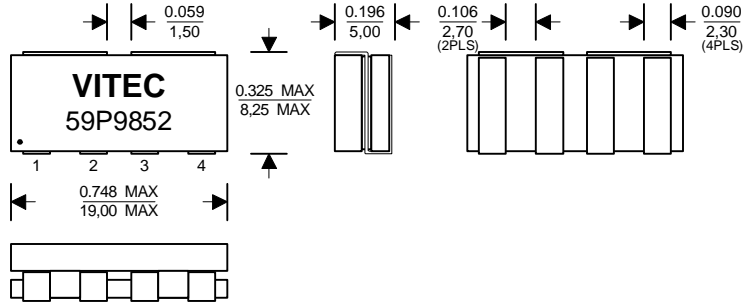

Dimensions: Inches/mm. Tolerances: +/- 0.010"/0,25mm unless otherwise noted

Multi-Phase SMD Coupled Inductor

Designed for Advanced Voltage Regulator Modules

PACKAGE - Continued

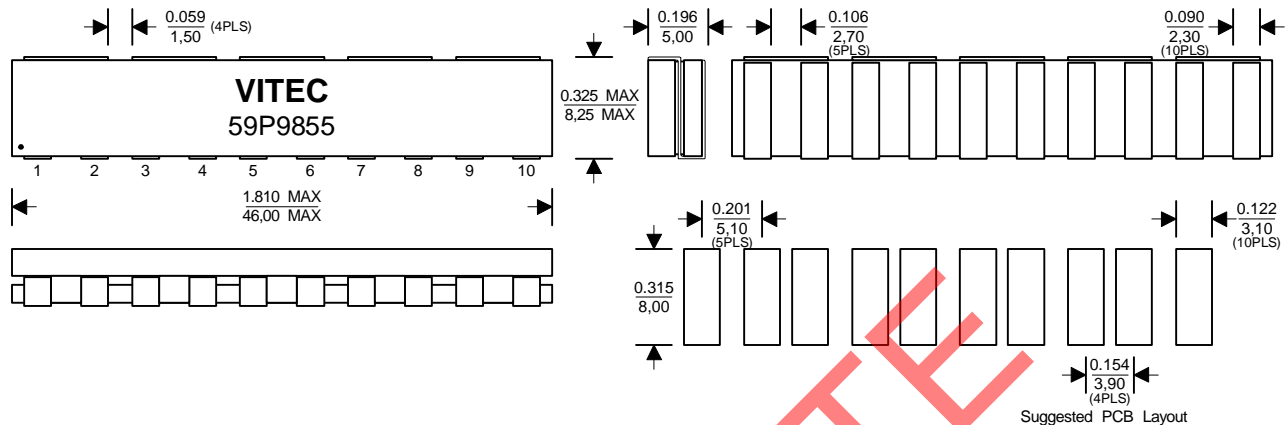

59P9852

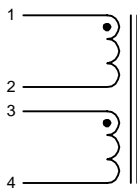

59P9853

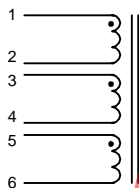

59P9854

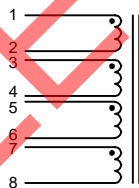

59P9855

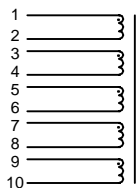

ELECTRICAL CHARACTERISTICS @ 25°C (unless otherwise noted)

Part Number		Phase Inductance (1)(2)	Phase Rated Current (4)(2)	Inductance @ 0 Adc (3)					Inductance @ 5 Adc (3)					DCR		
				L (1-2)	L (3-4)	L (5-6)	L (7-8)	L (9-10)	L (1-2)	L (3-4)	L (5-6)	L (7-8)	L (9-10)	mOhm TYP	mOhm MAX	
Classic	RoHS	nH ± 20%	ADC TYP	nH MIN	nH MIN	nH MIN	nH MIN	nH MIN	nH MIN	nH MIN	nH MIN	nH MIN	nH MIN	nH MIN		
59P9852	59PR9852	50	40	330	330	-	-	-	260	260	-	-	-	0.53	0.59	
59P9853	59PR9853	50	40	360	440	360	-	-	290	400	290	-	-	0.53	0.59	
59P9854	59PR9854	50	40	360	440	440	360	-	290	400	400	290	-	0.53	0.59	
59P9855	59PR9855	50	40	360	440	440	440	360	290	400	400	400	290	0.53	0.59	

Add an "R" to the part number after "P" for the RoHS compliant version (i.e. 59PR9852 is the RoHS compliant version of 59P9852).

Notes:

- (1) - Controlled by design based on Volterra's testing.
- (2) - Additional information on the in-circuit operation can be obtained by contacting Volterra.
- (3) - Open circuit inductance of each inductor, measured @100KHz and 1.0Vrms.
- (4) - Rated current per phase is based on practical thermal limits determined by Volterra.

ENVIRONMENTAL & RELIABILITY DATA

Storage Temperature: -40C to +125C
 Operating Temperature: -40C to +125C
 Resistance to Solder Reflow: 3 passes thru. +235C for 30 seconds minimum

Marking permanency: Tested per JESD22-B107-A
 Solderability: Tested per MIL-STD-750D
 Life Test: Tested per MIL-STD-202F, Method 108A
 Thermal Cycle: Tested per JESD22-B104-B, Test Condition G

Multi-Phase SMD Coupled Inductor

Designed for Advanced Voltage Regulator Modules

IR Profile

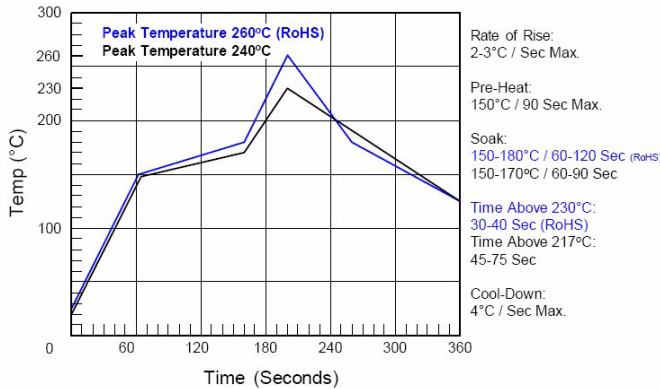

Tape and Reel

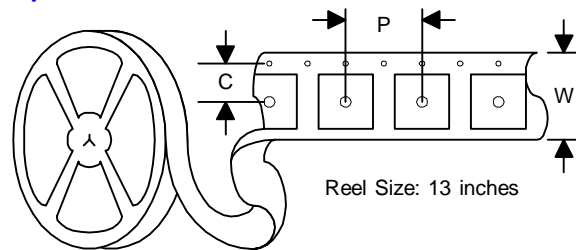

DIM	59P9852	59P9853	59P9854	59P9855
C	0.559 / 14,20	0.795 / 20,20	1.031 / 26,20	1.346 / 34,20
W	1.259 / 32,00	1.732 / 44,00	2.205 / 56,00	2.835 / 72,00
P	0.630 / 16,00	0.630 / 16,00	0.630 / 16,00	0.630 / 16,00
QTY/Reel	750	750	400	400

ABOUT US

Vitec Electronics Corporation, founded in 1986, is a worldwide leader in the design, manufacture and sale of magnetic solutions. Vitec's market focus includes the power, power conditioning, telecom, networking, communications and computing. Vitec has also established strong alliances with chip manufacturers whereby magnetic solutions are designed in conjunction with unique silicon requirements and are offered as reference designs by the chip companies.

With its Corporate Headquarters and Research & Development center located in Carlsbad, California, and its state of the art manufacturing facility and material sourcing in China, Vitec is uniquely positioned to supply the latest technology at the lowest cost. Vitec offers both standard and custom product design capabilities with all of its facilities being ISO certified.

QUALITY POLICY

Vitec will provide products and services that meet or exceed our Customer's requirements, conform to company policies and standards, and exhibit continuously improving levels of Quality.

COMMITMENT

VITEC Electronics empowers each of its employees by providing a business environment that encourages a commitment to excellence, a sense of ownership and personal accountability to all Vitec Customers.

Competitive Pricing, Quality Products, and On Time Deliveries are expected from today's World Class Magnetics Suppliers. The high standards of today's customer are strengthening the dedication and commitment of VITEC Electronics to provide Total Customer Service.

CONTACT US

USA

VITEC ELECTRONICS CORPORATION
6213 El Camino Real
Carlsbad, CA 92009
U.S.A.

TEL: +1 (760) 918-8831
FAX: +1 (760) 918-8840

ASIA

SHANGHAI VITEC ELECTRONICS CO., LTD.
3369 He Chuan Road
Min Hang District, Shanghai, 201103
China

TEL: +86 (21) 6446-4828
FAX: +86 (21) 6446-4865

Multi-Phase SMD Coupled Inductor

Designed for Advanced Voltage Regulator Modules

FEATURES

- Designed for use with Volterra Semiconductor's 4th generation synchronous buck voltage regulator chipsets.
- Lowest output ripple current with less output capacitors.
- Up to 2MHz operating frequency.
- Extended operating temperature range: -40°C to 125°C.
- Robust SMD package capable of handling the most aggressive SMT assembly process.
- US Patent Number 6,362,986.
- RoHS Compliant Version Available.
- Faster transient response and higher efficiency.

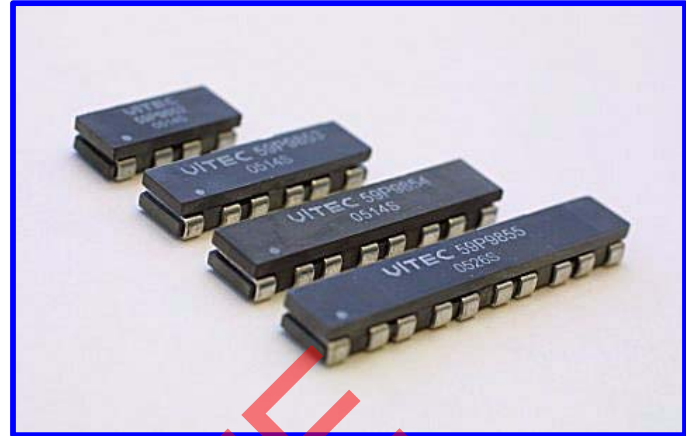

APPLICATIONS

- VRD and VRM 10.x and 11.x based designs
- Multi-Phase Switching regulator designs using Volterra VT1105M®, VT1115M® chipsets only
- Server, Desktop, Graphics cards, Notebook computers, DDR, telecom switches and routers

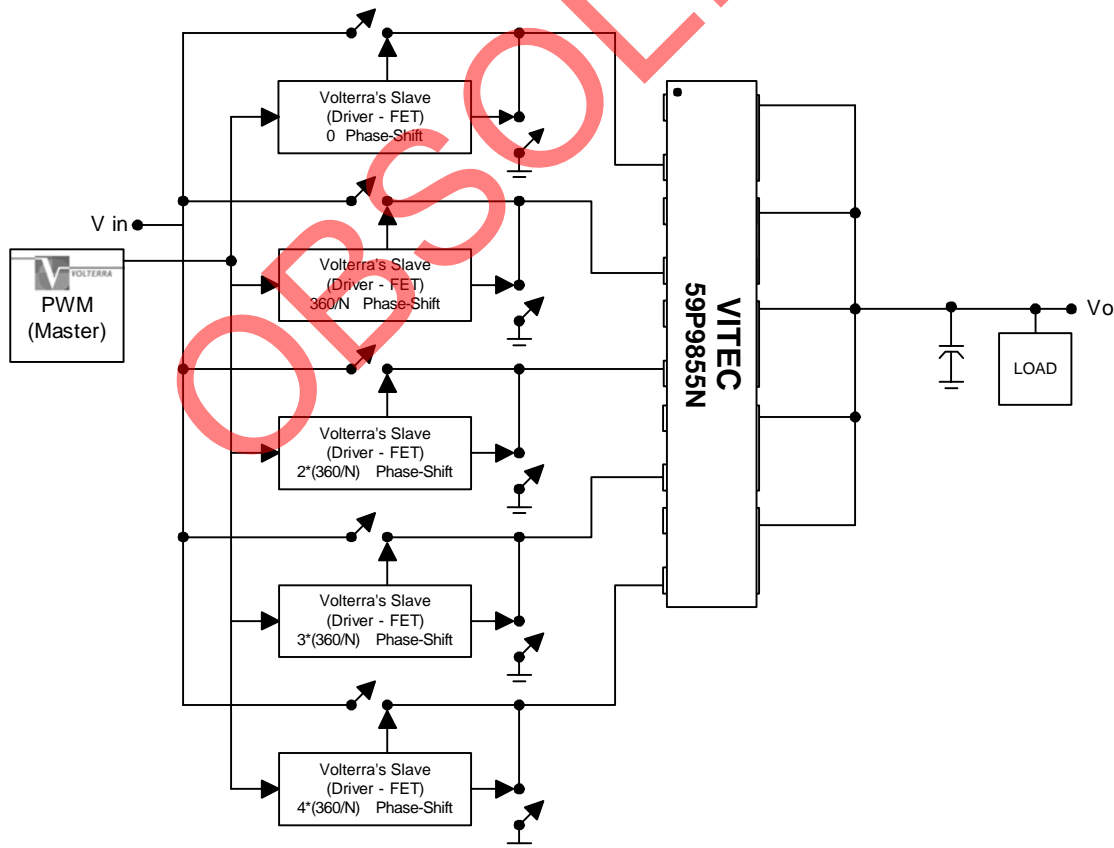

Typical Multi-Phase Application Circuit for a Synchronous Buck Converter

Multi-Phase SMD Coupled Inductor

Designed for Advanced Voltage Regulator Modules

PACKAGE

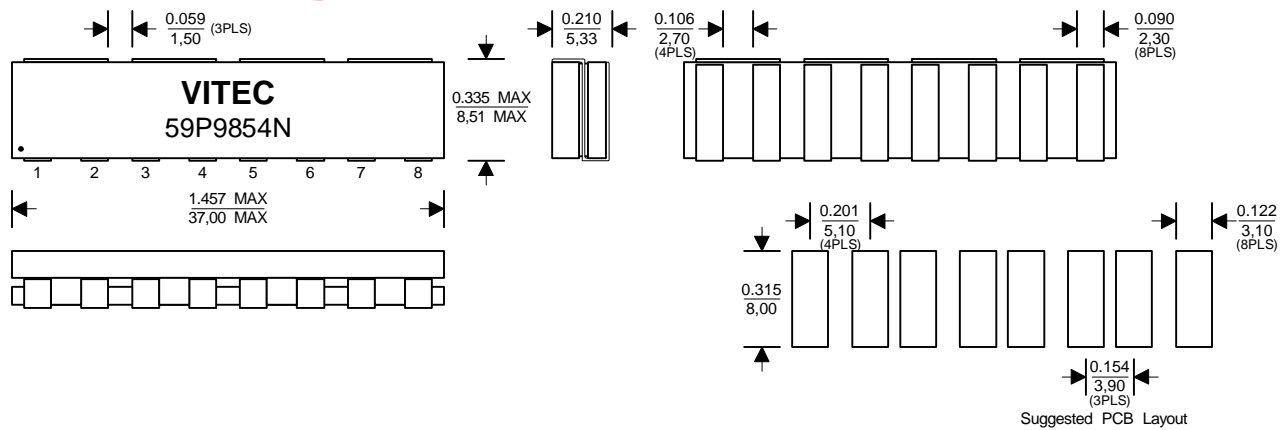
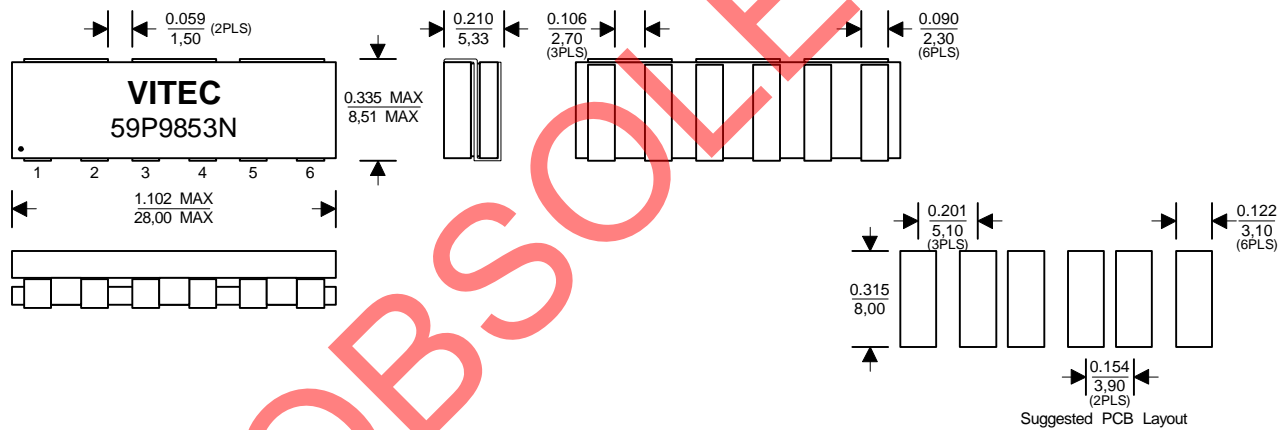
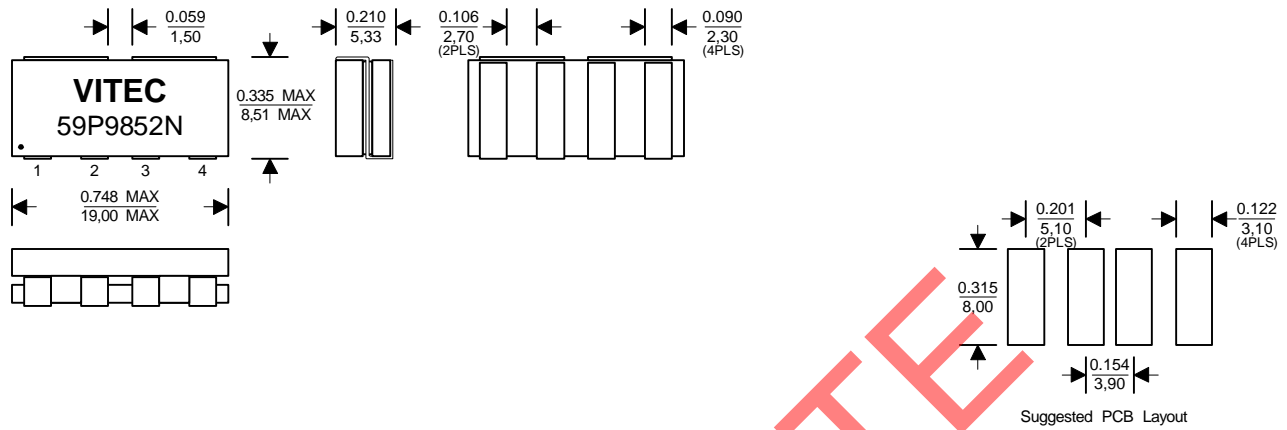

Dimensions: Inches/mm. Tolerances: +/- 0.010"/0,25mm unless otherwise noted

Multi-Phase SMD Coupled Inductor

Designed for Advanced Voltage Regulator Modules

PACKAGE - Continued

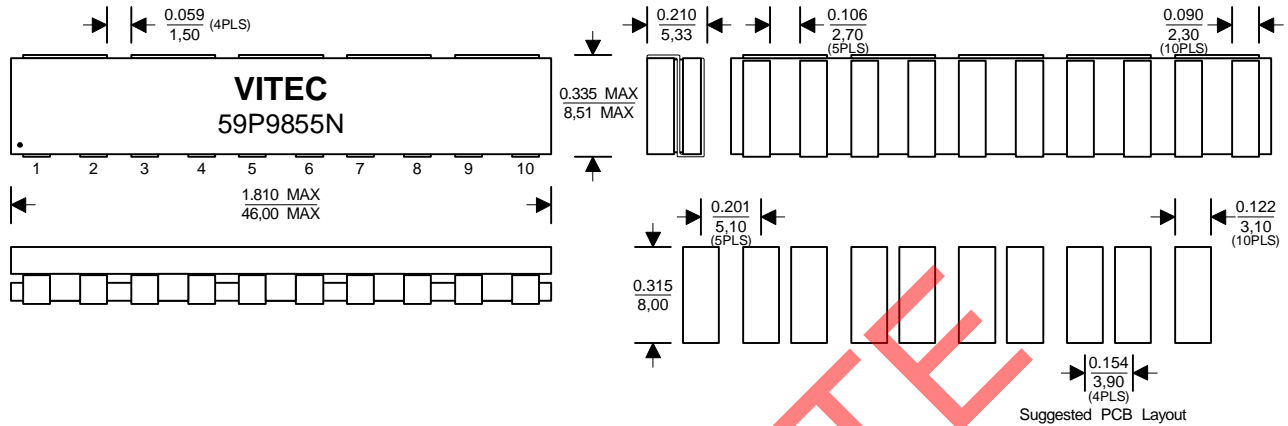

59P9852

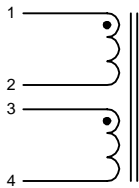

59P9853

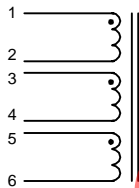

59P9854

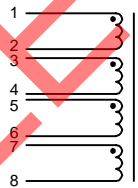

59P9855

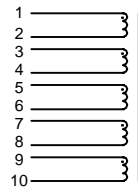

ELECTRICAL CHARACTERISTICS @ 25°C (unless otherwise noted)

Part Number		Phase Inductance (1)(2)	Phase Rated Current (4)(2)	Inductance @ 0 Adc (3)					Inductance @ 5 Adc (3)					DCR	
				L (1-2)	L (3-4)	L (5-6)	L (7-8)	L (9-10)	L (1-2)	L (3-4)	L (5-6)	L (7-8)	L (9-10)		
Classic	RoHS	nH ± 20%	ADC TYP	nH MIN	nH MIN	nH MIN	nH MIN	nH MIN	nH MIN	nH MIN	nH MIN	nH MIN	nH MIN	mOhm TYP	mOhm MAX
59P9852N	59PR9852N	50	40	330	330	-	-	-	260	260	-	-	-	0.37	0.41
59P9853N	59PR9853N	50	40	360	440	360	-	-	290	400	290	-	-	0.37	0.41
59P9854N	59PR9854N	50	40	360	440	440	360	-	290	400	400	290	-	0.37	0.41
59P9855N	59PR9855N	50	40	360	440	440	440	360	290	400	400	400	290	0.37	0.41

Add an "R" to the part number after "P" for the RoHS compliant version (i.e. 59PR9852N is the RoHS compliant version of 59P9852N).

Notes:

- (1) - Controlled by design based on Volterra's testing.
- (2) - Additional information on the in-circuit operation can be obtained by contacting Volterra.
- (3) - Open circuit inductance of each inductor, measured @100KHz and 1.0Vrms.
- (4) - Rated current per phase is based on practical thermal limits determined by Volterra.

ENVIRONMENTAL & RELIABILITY DATA

Storage Temperature: -40C to +125C
 Operating Temperature: -40C to +125C
 Resistance to Solder Reflow: 3 passes thru. +235C for 30 seconds minimum

Marking permanency: Tested per JESD22-B107-A
 Solderability: Tested per MIL-STD-750D
 Life Test: Tested per MIL-STD-202F, Method 108A
 Thermal Cycle: Tested per JESD22-B104-B, Test Condition G

Multi-Phase SMD Coupled Inductor

Designed for Advanced Voltage Regulator Modules

IR Profile

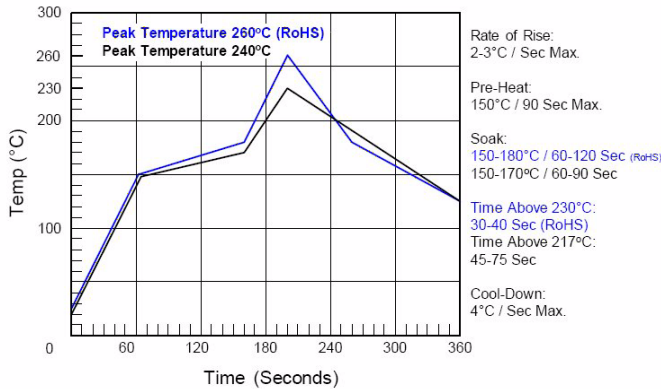

Tape and Reel

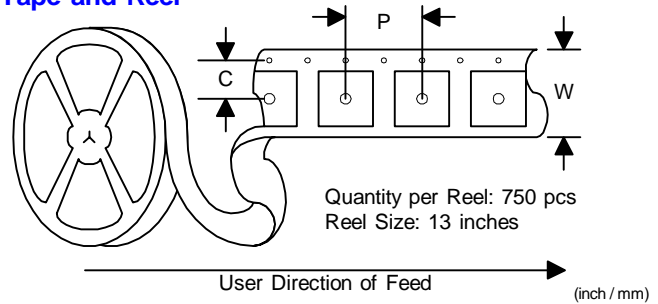

DIM	59P9852N	59P9853N	59P9854N	59P9855N
C	0.559 / 14,20	0.795 / 20,20	1.031 / 26,20	1.346 / 34,20
W	1.259 / 32,00	1.732 / 44,00	2.205 / 56,00	2.835 / 72,00
P	0.630 / 16,00	0.630 / 16,00	0.630 / 16,00	0.630 / 16,00
QTY/Reel	750	750	400	400

ABOUT US

Vitec Electronics Corporation, founded in 1986, is a worldwide leader in the design, manufacture and sale of magnetic solutions. Vitec's market focus includes the power, power conditioning, telecom, networking, communications and computing. Vitec has also established strong alliances with chip manufacturers whereby magnetic solutions are designed in conjunction with unique silicon requirements and are offered as reference designs by the chip companies.

With its Corporate Headquarters and Research & Development center located in Carlsbad, California, and its state of the art manufacturing facility and material sourcing in China, Vitec is uniquely positioned to supply the latest technology at the lowest cost. Vitec offers both standard and custom product design capabilities with all of its facilities being ISO certified.

QUALITY POLICY

Vitec will provide products and services that meet or exceed our Customer's requirements, conform to company policies and standards, and exhibit continuously improving levels of Quality.

COMMITMENT

VITEC Electronics empowers each of its employees by providing a business environment that encourages a commitment to excellence, a sense of ownership and personal accountability to all Vitec Customers.

Competitive Pricing, Quality Products, and On Time Deliveries are expected from today's World Class Magnetics Suppliers. The high standards of today's customer are strengthening the dedication and commitment of VITEC Electronics to provide Total Customer Service.

CONTACT US

USA

VITEC ELECTRONICS CORPORATION
6213 El Camino Real
Carlsbad, CA 92009
U.S.A.

TEL: +1 (760) 918-8831
FAX: +1 (760) 918-8840

ASIA

SHANGHAI VITEC ELECTRONICS CO., LTD.
3369 He Chuan Road
Min Hang District, Shanghai, 201103
China

TEL: +86 (21) 6446-4828
FAX: +86 (21) 6446-4865

SMD High Frequency Power Inductor

Designed for VRD & VRM 10.x & 11.x Applications

FEATURES

- Recommended for use with all major Voltage Regulator ICs
- High Current handling capability in the smallest footprint
- Up to 2MHz operating frequency
- Extended operating temperature range: -40C to 125C
- Robust SMD package capable of handling the most aggressive SMT assembly process
- RoHS compliant
- 100% tested to a 10% DCR tolerance

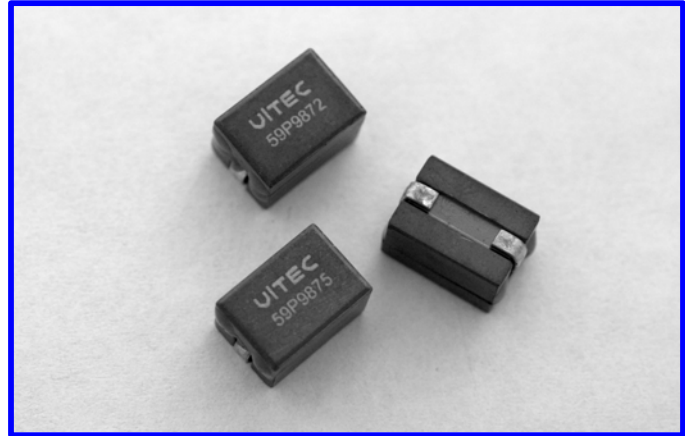

APPLICATIONS

- VRD and VRM 10.x and 11.x based designs
- Multi-Phase Voltage regulator designs
- Server, Desktop, PDA, Graphics cards, Notebook computers, DDR, telecom switches and routers
- DC-DC converters, Battery powered devices, high current power supplies
- High Current NPUs in networking equipment
- Point-of-load Modules
- DCR sensing

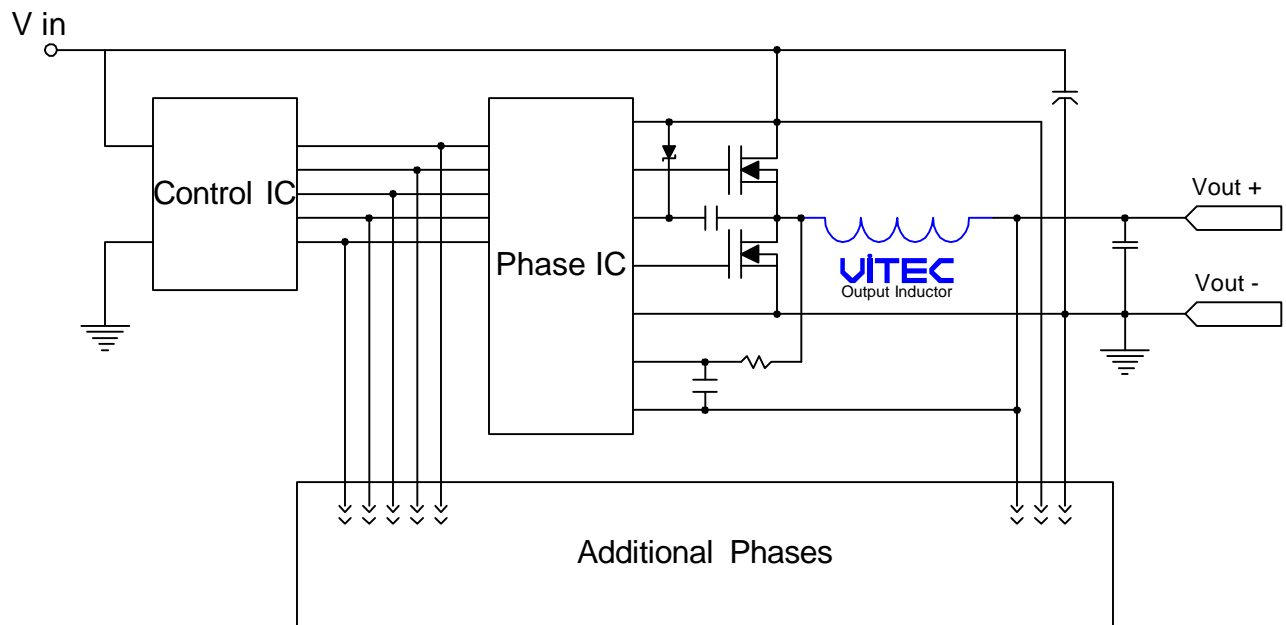

Typical Multi-Phase Application Circuit for a Buck Converter

SMD High Frequency Power Inductor

Designed for VRD & VRM 10.x & 11.x Applications

PACKAGE

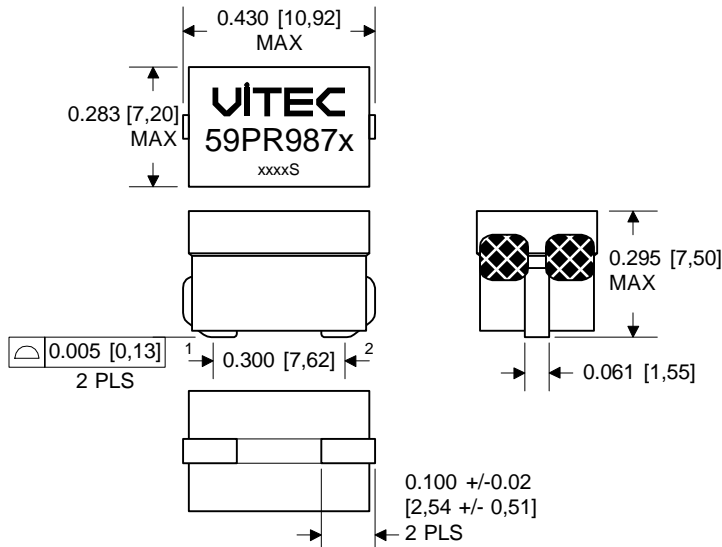

Dimensions: Inches [mm]. Tolerances: +/- 0.005" [0,13mm] unless otherwise noted

SCHEMATIC

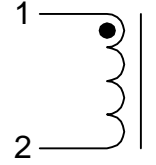

SUGGESTED PCB LAYOUT

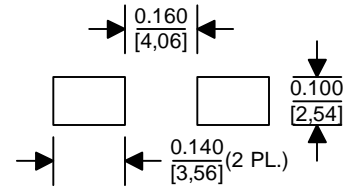

Drawing NOT to scale

ELECTRICAL CHARACTERISTICS @ 25°C (unless otherwise noted)

Part Number		Inductance ⁴ @ 0 Adc	Inductance ⁴ @ Isat ² (25°C)	DCR	Isat ² (Max Saturation Current)			Temp. Rise Current ³	Temp. Rise Factor A (TRF A) ⁵	Temp. Rise Factor B (TRF B) ⁵	Temp. Rise Factor C (TRF C) ⁵
					ADC						
Classic	RoHS	± 15%	MIN	± 10%	25°C	100°C	125°C	MAX			
59P9870	59PR9870	70	48	0.47	138	120	116	35	5.26	0.004428	0.01364
59P9871	59PR9871	120	82	0.47	87	76	73	35	5.26	0.004296	0.02357
59P9872	59PR9872	150	102	0.47	70	60	58	35	5.26	0.004265	0.02950
59P9873	59PR9873	220	156	0.47	47	41	39	35	5.26	0.004223	0.04334
59P9874	59PR9874	300	204	0.47	34	30	29	35	5.26	0.004203	0.05914
59P9875	59PR9875	400	272	0.47	23	20	19	35	5.26	0.004191	0.07887
59P9876	59PR9876	510	347	0.47	17	15	14	35	5.26	0.004183	0.10057

Add an "R" to the part number after "P" for the RoHS compliant version (i.e. 59PR9871 is the RoHS compliant version of 59P9871).

- The Rated Current (Irated) is either the Saturation Current at 25°C or the Temperature Rise Current; the lowest number of the two specified currents.
- The Saturation Current (Isat) is the current at which the Inductance drops by a maximum of 20% below the lower limit of its value specified at 0 ADC Bias. Inductance at Isat is measured at the specified Ambient Temperature by applying DC Bias by a short period of time to minimize the self-heating effect of the component.
- The Temperature Rise Current is the current at which the temperature of the part increases by 50°C. This test is performed with the part mounted on a PCB with traces having 1.7 times the cross sectional area of the copper leads of the part. The temperature of the part is measured after applying the DC current for a minimum of 10 minutes.
- Inductance is measured at 100 KHz and 1.0 Vrms.
- Temperature Rise can be estimated using the following formulas:

$$T_{rise} (°C) = \left(\frac{\text{Core Loss} + \text{DCR Loss}}{\text{TRF A}} \right)^{0.833}$$

$$\text{DCR Loss (mW)} = \left(I_{dc}^2 + \left(\frac{\Delta I}{2} \right)^2 \right) \times \text{TYP DCR (mOhms)}$$

$$\text{Core Loss (mW)} = \text{TRF B} \times (F)^{1.84} \times (\text{TRF C} \times \Delta I)^{2.28}$$

IDC = DC output current (ADC)
 ΔI = Delta I across the inductor (Amps)
 F = Switching frequency (kHz)

SMD High Frequency Power Inductor

Designed for VRD & VRM 10.x & 11.x Applications

59PR9870 Inductance vs. Idc @ 25°C

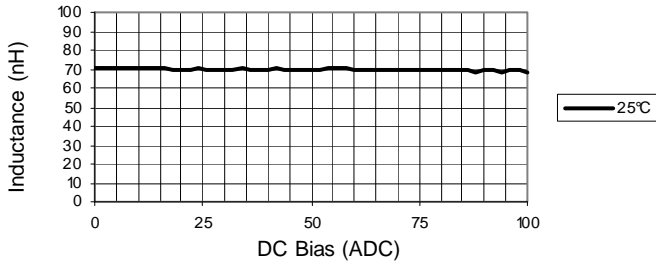

59PR9871 Inductance vs. Idc @ 25°C

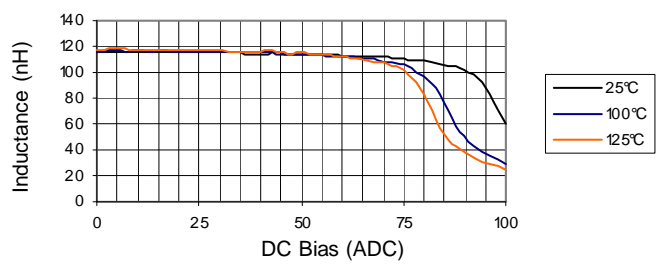

59PR9872 Inductance vs. Idc @ 25°C

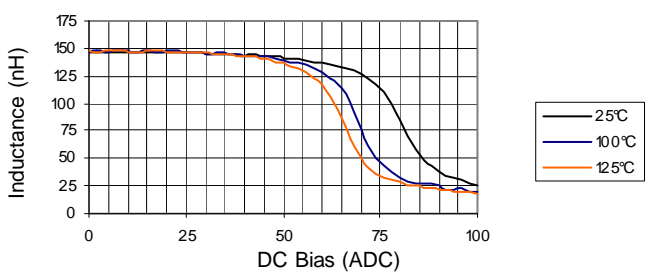

59PR9873 Inductance vs. Idc @ 25°C

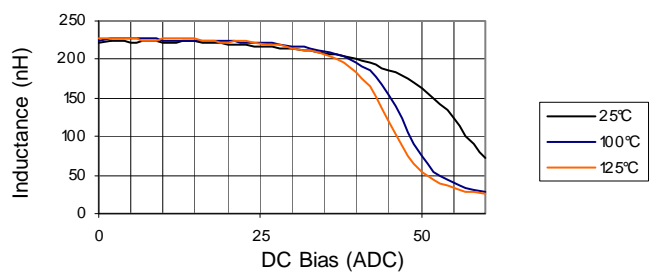

59PR9874 Inductance vs. Idc @ 25°C

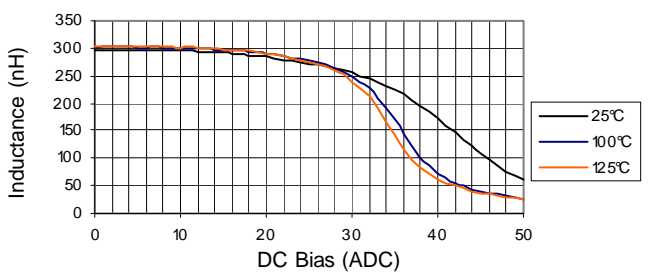

59PR9875 Inductance vs. Idc @ 25°C

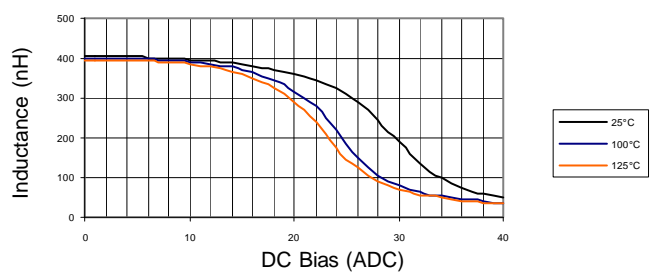

59PR9876 Inductance vs. Idc @ 25°C

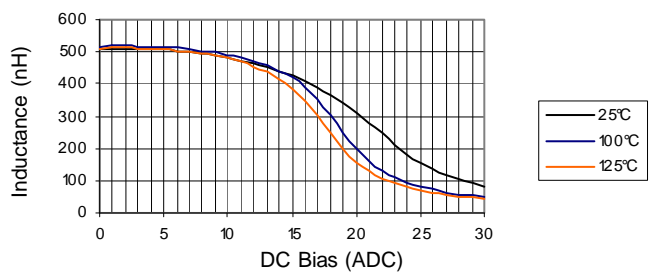

59PR987X Temp. Rise vs. Idc

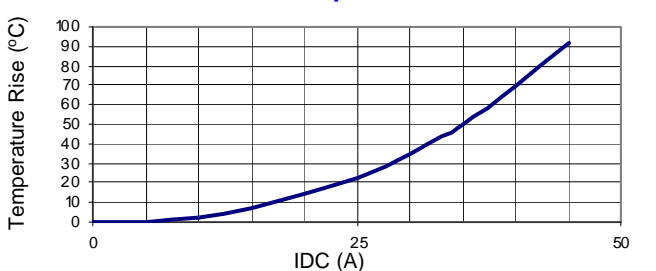

59PR987X Rdc vs. Temp. Rise

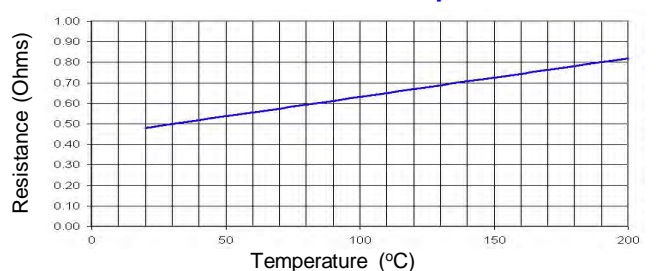

SMD High Frequency Power Inductor

Designed for VRD & VRM 10.x & 11.x Applications

IR Profile

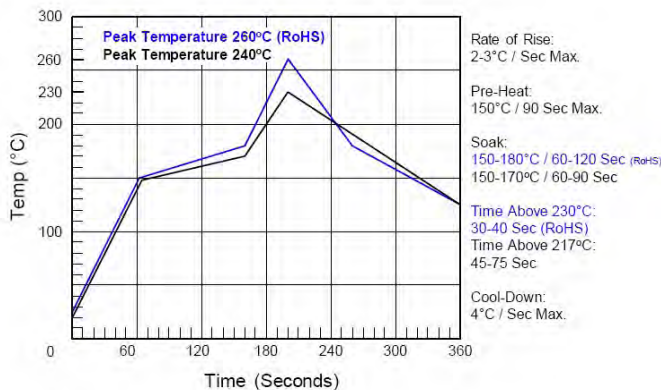

Tape and Reel

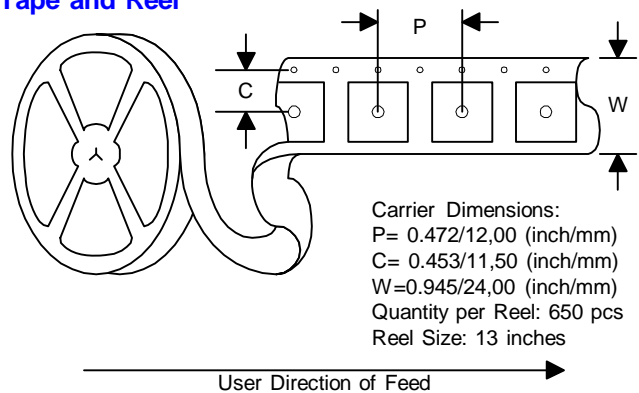

ENVIRONMENTAL & RELIABILITY DATA

Storage Temperature: -40C to +125C
Operating Temperature: -40C to +125C
Resistance to Solder Reflow: 3 passes thru. +235C for 30 seconds minimum

Marking permanency: Tested per JESD22-B107-A
Solderability: Tested per MIL-STD-750D
Life Test: Tested per MIL-STD-202F, Method 108A
Thermal Cycle: Tested per JESD22-B104-B, Test Condition G

ABOUT US

Vitec Electronics Corporation, founded in 1986, is a worldwide leader in the design, manufacture and sale of magnetic solutions. Vitec's market focus includes the power, power conditioning, telecom, networking, communications and computing. Vitec has also established strong alliances with chip manufacturers whereby magnetic solutions are designed in conjunction with unique silicon requirements and are offered as reference designs by the chip companies.

With its Corporate Headquarters and Research & Development center located in Carlsbad, California, and its state of the art manufacturing facility and material sourcing in China, Vitec is uniquely positioned to supply the latest technology at the lowest cost. Vitec offers both standard and custom product design capabilities with all of its facilities being ISO certified.

QUALITY POLICY

Vitec will provide products and services that meet or exceed our Customer's requirements, conform to company policies and standards, and exhibit continuously improving levels of Quality.

COMMITMENT

VITEC Electronics empowers each of its employees by providing a business environment that encourages a commitment to excellence, a sense of ownership and personal accountability to all Vitec Customers.

Competitive Pricing, Quality Products, and On Time Deliveries are expected from today's World Class Magnetics Suppliers. The high standards of today's customer are strengthening the dedication and commitment of VITEC Electronics to provide Total Customer Service.

CONTACT US

USA

VITEC ELECTRONICS CORPORATION
6213 El Camino Real
Carlsbad, CA 92009
U.S.A.

TEL: +1 (760) 918-8831
FAX: +1 (760) 918-8840

ASIA

SHANGHAI VITEC ELECTRONICS CO., LTD.
3369 He Chuan Road
Min Hang District, Shanghai, 201103
China

TEL: +86 (21) 6446-4828
FAX: +86 (21) 6446-4865

SMD High Frequency Power Inductor

Designed for VRD & VRM 10.x & 11.x Applications

FEATURES

- Recommended for use with all major Voltage Regulator ICs
- High Current handling capability in the smallest footprint
- Up to 2MHz operating frequency
- Extended operating temperature range: -40C to 125C
- Robust SMD package capable of handling the most aggressive SMT assembly process
- RoHS compliant
- 100% tested to a 10% DCR tolerance

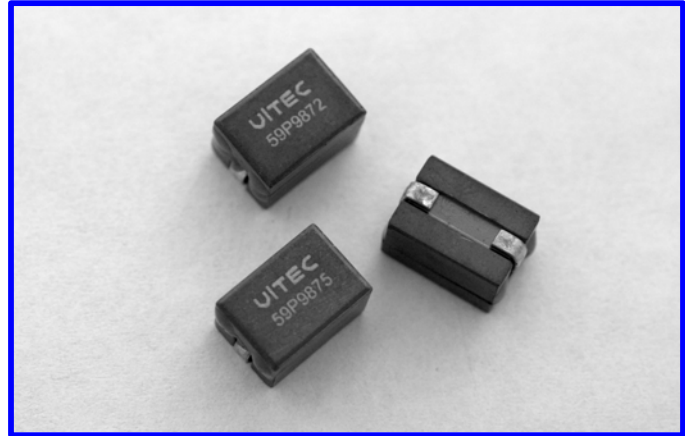

APPLICATIONS

- VRD and VRM 10.x and 11.x based designs
- Multi-Phase Voltage regulator designs
- Server, Desktop, PDA, Graphics cards, Notebook computers, DDR, telecom switches and routers
- DC-DC converters, Battery powered devices, high current power supplies
- High Current NPUs in networking equipment
- Point-of-load Modules
- DCR sensing

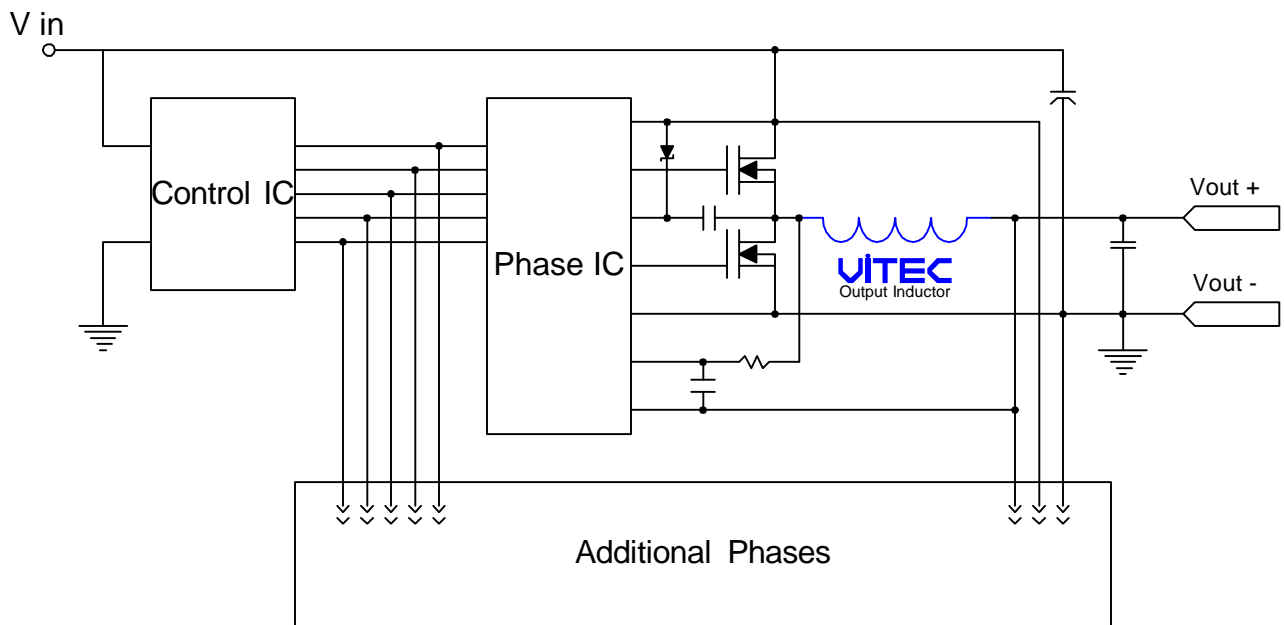

Typical Multi-Phase Application Circuit for a Buck Converter

SMD High Frequency Power Inductor

Designed for VRD & VRM 10.x & 11.x Applications

PACKAGE

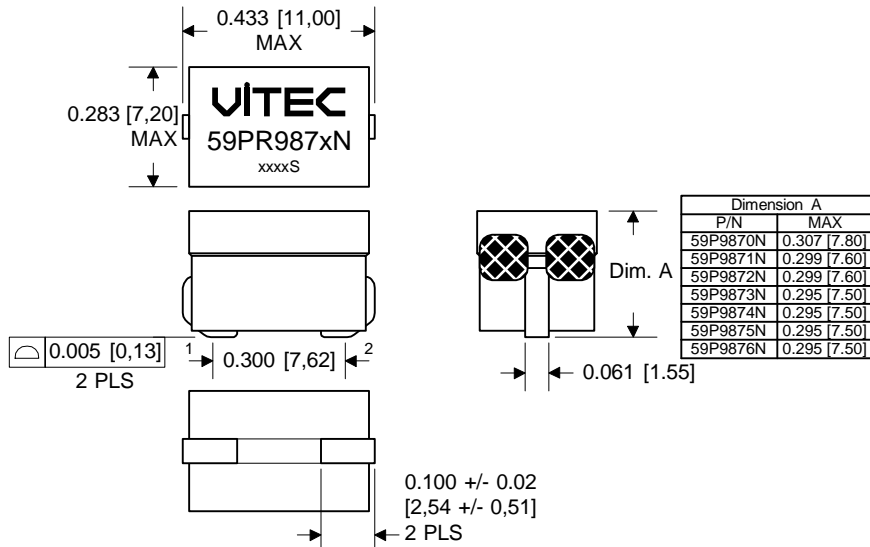

Dimensions: Inches [mm]. Tolerances: +/- 0.005" [0,13mm] unless otherwise noted

SCHEMATIC

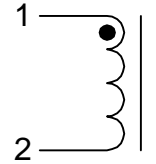

SUGGESTED PCB LAYOUT

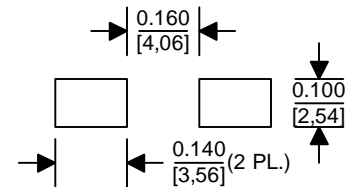

Drawing NOT to scale

ELECTRICAL CHARACTERISTICS @ 25°C (unless otherwise noted)

Part Number		Inductance ³ @ 0 Adc	Inductance ³ @ Isat ¹ (25°C)	DCR	Isat ¹ (Max Saturation Current)			Temp. Rise Current ²	Temp. Rise Factor A (TRF A) ⁴	Temp. Rise Factor B (TRF B) ⁴	Temp. Rise Factor C (TRF C) ⁴
					ADC						
Classic	RoHS	± 15%	MIN	± 10%	25°C	100°C	125°C	MAX			
59P9870N	59PR9870N	70	48	0.29	138	120	116	48	6.10	0.004428	0.01364
59P9871N	59PR9871N	120	82	0.29	87	76	73	48	6.10	0.004296	0.02357
59P9872N	59PR9872N	150	102	0.29	70	60	58	48	6.10	0.004265	0.02950
59P9873N	59PR9873N	220	150	0.29	47	41	39	48	6.10	0.004223	0.04334
59P9874N	59PR9874N	300	204	0.29	34	30	29	48	6.10	0.004203	0.05914
59P9875N	59PR9875N	400	272	0.29	23	20	19	48	6.10	0.004191	0.07887
59P9876N	59PR9876N	510	347	0.29	17	15	14	48	6.10	0.004183	0.10057

Add an "R" to the part number after "P" for the RoHS compliant version (i.e. 59PR9871N is the RoHS compliant version of 59P9871N).

- The Saturation Current (Isat) is the current at which the Inductance drops by a maximum of 20% below the lower limit of its value specified at 0 ADC Bias. Inductance at Isat is measured at the specified Ambient Temperature by applying DC Bias by a short period of time to minimize the self-heating effect of the component.
- The Temperature Rise Current is the current at which the temperature of the part increases by 50°C. This test is performed with the part mounted on a PCB with traces having 1.7 times the cross sectional area of the copper leads of the part. The temperature of the part is measured after applying the DC current for a minimum of 10 minutes.
- Inductance is measured at 100 KHz and 1.0 Vrms.
- Temperature Rise can be estimated using the following formulas:

$$Trise (°C) = \left(\frac{\text{Core Loss} + \text{DCR Loss}}{\text{TRF A}} \right)^{0.833}$$

$$\text{DCR Loss (mW)} = \left(I_{dc}^2 + \left(\frac{\Delta I}{2} \right)^2 \right) \times \text{TYP DCR (mOhms)}$$

$$\text{Core Loss (mW)} = \text{TRF B} \times (F)^{1.84} \times (\text{TRF C} \times \Delta I)^{2.28}$$

IDC = DC output current (ADC)
 ΔI = Delta I across the inductor (Amps)
 F = Switching frequency (kHz)

SMD High Frequency Power Inductor

Designed for VRD & VRM 10.x & 11.x Applications

59PR9870N Inductance vs. I_{dc} @ 25°C

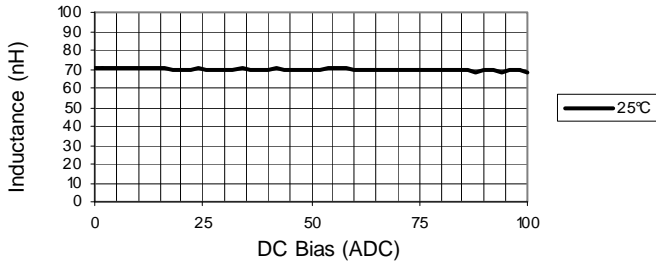

59PR9871N Inductance vs. I_{dc} @ 25°C

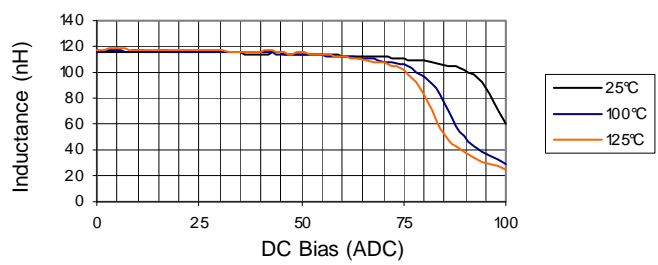

59PR9872N Inductance vs. I_{dc} @ 25°C

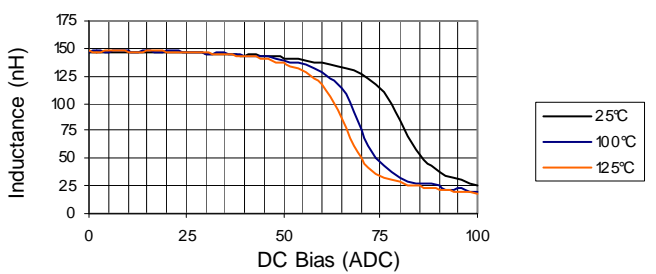

59PR9873N Inductance vs. I_{dc} @ 25°C

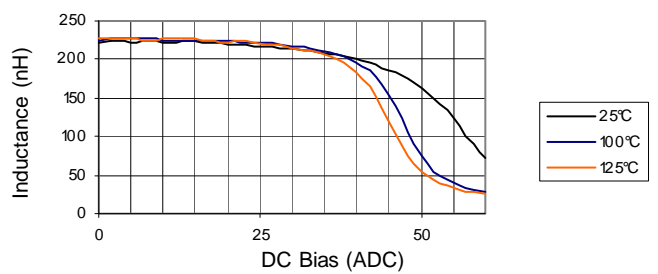

59PR9874N Inductance vs. I_{dc} @ 25°C

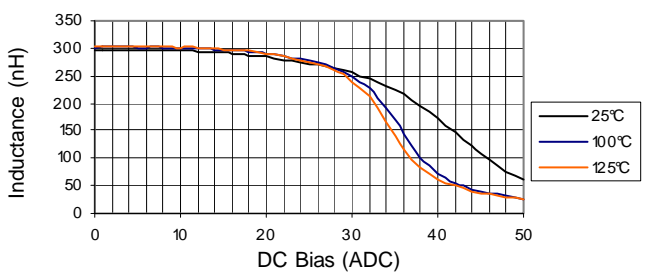

59PR9875N Inductance vs. I_{dc} @ 25°C

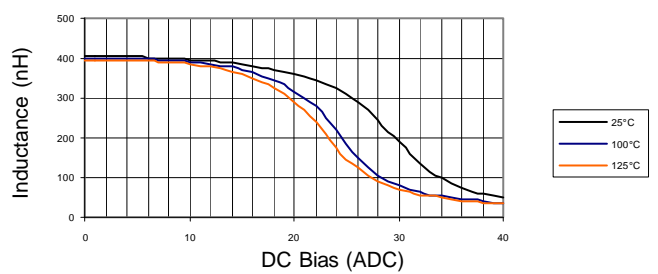

59PR9876N Inductance vs. I_{dc} @ 25°C

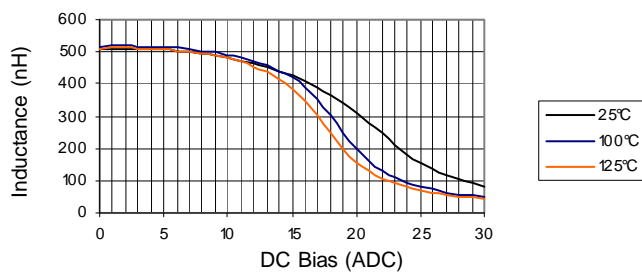

59PR987XN Temp. Rise vs. I_{dc}

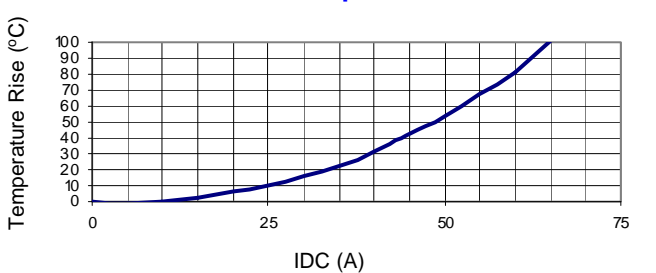

59PR987XN R_{dc} vs. Temp. Rise

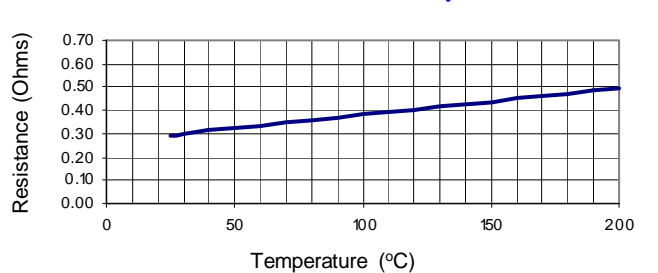

SMD High Frequency Power Inductor

Designed for VRD & VRM 10.x & 11.x Applications

IR Profile

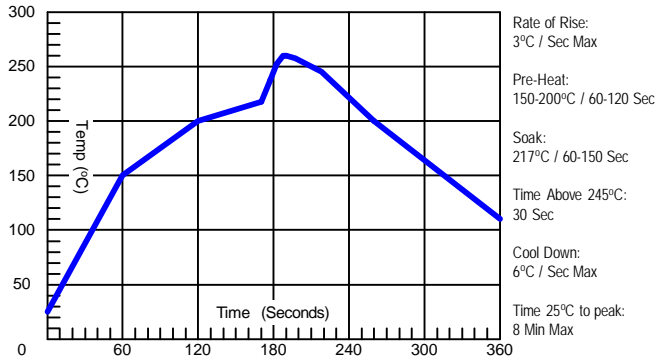

Tape and Reel

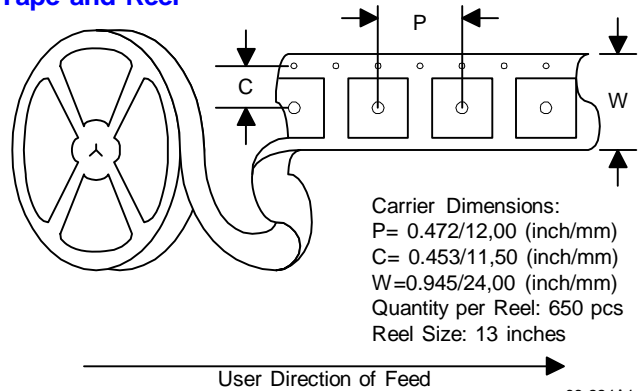

ENVIRONMENTAL & RELIABILITY DATA

Storage Temperature: -40C to +125C
Operating Temperature: -40C to +125C
Resistance to Solder Reflow: 3 passes thru. +235C for 30 seconds minimum

Marking permanency: Tested per JESD22-B107-A
Solderability: Tested per MIL-STD-750D
Life Test: Tested per MIL-STD-202F, Method 108A
Thermal Cycle: Tested per JESD22-B104-B, Test Condition G

ABOUT US

Vitec Electronics Corporation, founded in 1986, is a worldwide leader in the design, manufacture and sale of magnetic solutions. Vitec's market focus includes the power, power conditioning, telecom, networking, communications and computing. Vitec has also established strong alliances with chip manufacturers whereby magnetic solutions are designed in conjunction with unique silicon requirements and are offered as reference designs by the chip companies.

With its Corporate Headquarters and Research & Development center located in Carlsbad, California, and its state of the art manufacturing facility and material sourcing in China, Vitec is uniquely positioned to supply the latest technology at the lowest cost. Vitec offers both standard and custom product design capabilities with all of its facilities being ISO certified.

QUALITY POLICY

Vitec will provide products and services that meet or exceed our Customer's requirements, conform to company policies and standards, and exhibit continuously improving levels of Quality.

COMMITMENT

VITEC Electronics empowers each of its employees by providing a business environment that encourages a commitment to excellence, a sense of ownership and personal accountability to all Vitec Customers.

Competitive Pricing, Quality Products, and On Time Deliveries are expected from today's World Class Magnetics Suppliers. The high standards of today's customer are strengthening the dedication and commitment of VITEC Electronics to provide Total Customer Service.

CONTACT US

USA

VITEC ELECTRONICS CORPORATION
6213 El Camino Real
Carlsbad, CA 92009
U.S.A.

TEL: +1 (760) 918-8831
FAX: +1 (760) 918-8840

ASIA

SHANGHAI VITEC ELECTRONICS CO., LTD.
3369 He Chuan Road
Min Hang District, Shanghai, 201103
China

TEL: +86 (21) 6446-4828
FAX: +86 (21) 6446-4865

SMD High Frequency Power Inductor

Designed for VRM 9.x, 10.x & 11.x Applications

FEATURES

- Recommended for use with all major Voltage Regulator ICs
- High Current handling capability in the smallest footprint & profile
- Up to 2MHz operating frequency
- Extended operating temperature range: -40C to 125C
- Robust SMD package capable of handling the most aggressive SMT assembly process
- RoHS compliant version available

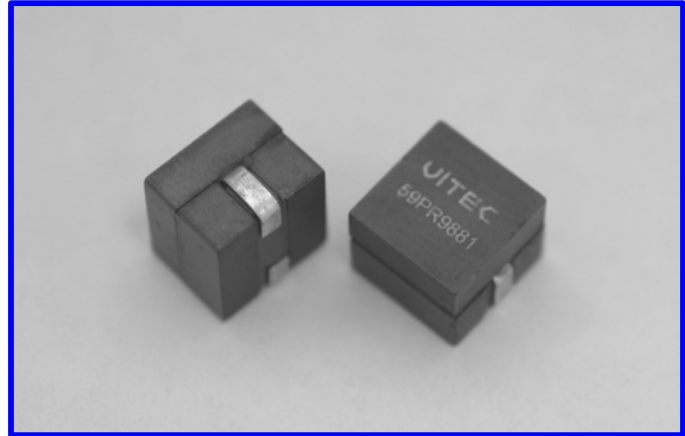

APPLICATIONS

- VRD and VRM 10.x and 11.x based designs
- Multi-Phase Voltage regulator designs
- Server, Desktop, PDA, Graphics cards, Notebook computers, DDR, telecom switches and routers
- DC-DC converters, Battery powered devices, high current power supplies
- High Current NPUs in networking equipment
- Point-of-load Modules
- DCR Sensing

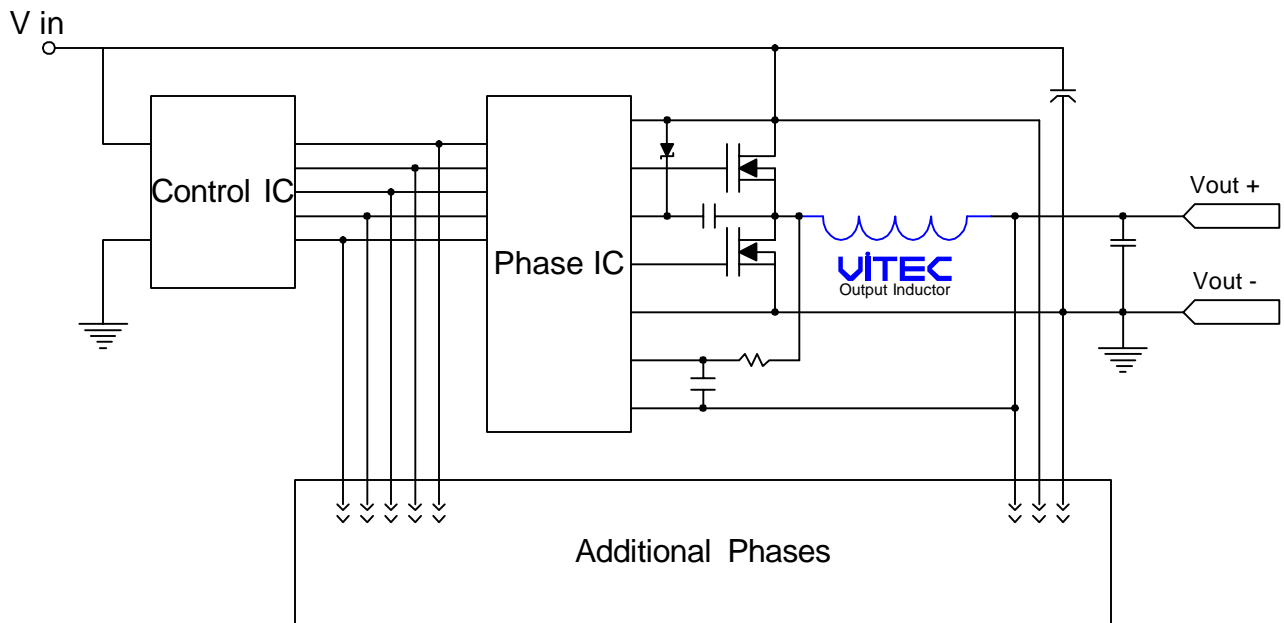

Typical Multi-Phase Application Circuit for a Buck Converter

SMD High Frequency Power Inductor

Designed for VRM 9.x, 10.x & 11.x Applications

PACKAGE

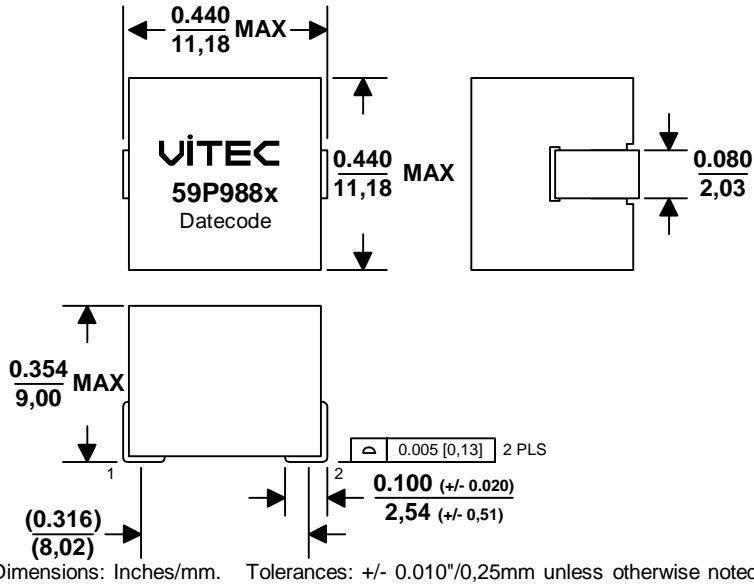

SCHEMATIC

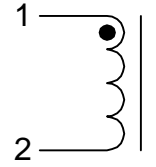

SUGGESTED PCB LAYOUT

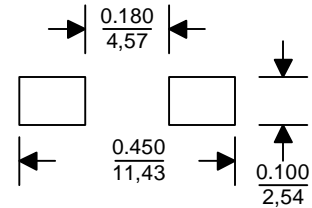

Drawing NOT to scale

ELECTRICAL CHARACTERISTICS @ 25°C (unless otherwise noted)

Part Number		Inductance @ 0Adc ⁴	Inductance @ Irated ⁴	Irated ¹	DCR	Saturation Current ²			Temp. Rise Current ³	Temp. Rise Factor ⁵
Classic	RoHS	nH ± 15%	nH MIN	ADC MAX	mOhm +/- 9%	ADC -40°C	ADC 25°C	ADC 125°C	ADC MAX	
59P9881	59PR9881	225	153	64	0.58	66	64	51	32	0.02756
59P9882	59PR9882	270	184	53	0.58	55	53	42	32	0.03309
59P9883	59PR9883	325	221	44	0.58	46	44	35	32	0.04045
59P9884	59PR9884	470	320	30	0.58	32	30	24	32	0.05766

Add an "R" to the part number after "P" for the RoHS compliant version (i.e. 59PR9881 is the RoHS compliant version of 59P9881).

Notes:

- The rated current is the saturation current @ 25°C.
- The I(Saturation) is the current at which the inductance drops by 20% maximum of its value at 0ADC. This current is measured at the stated ambient environment and by applying a short duration pulse current to the component, minimizing the self-heating effects.
- The I (Temp. Rise) is the current at which the temperature of the part increases by a maximum of 50°C. This test is performed with the part mounted on a PCB with traces having 2 times the cross sectional area of the copper leads and applying the DC current for a minimum of 10 minutes.
- Inductance is measured at 100 KHz and 1.0 Vrms.
- Temperature Rise can be estimated using the following formulas:

$$T_{rise} (^{\circ}C) = \left(\frac{\text{Core Loss} + \text{DCR Loss}}{5.42} \right)^{0.833}$$

$$\text{DCR Loss (mW)} = \left(I_{dc}^2 + \left(\frac{\Delta I}{2} \right)^2 \right) \times \text{TYP DCR (mOhms)}$$

$$\text{Core Loss (mW)} = 0.00852 \times (F)^{1.84} \times (\text{Temp. Rise factor} \times \Delta I)^{2.26}$$

IDC = DC output current (ADC)
 ΔI = Delta I across the inductor (Amps)
 F = Switching frequency (kHz)

SMD High Frequency Power Inductor

Designed for VRM 9.x, 10.x & 11.x Applications

59P9881 Inductance vs. I_{dc} @ 25°C

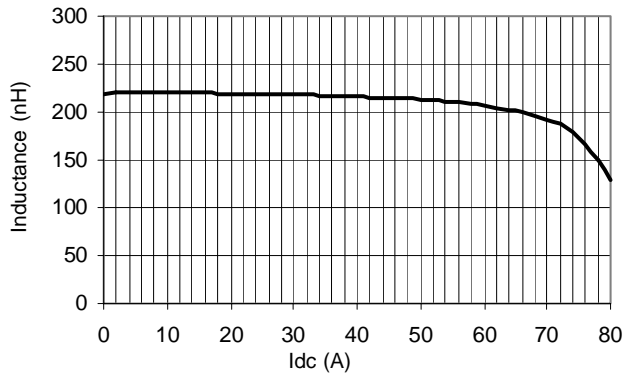

59P9882 Inductance vs. I_{dc} @ 25°C

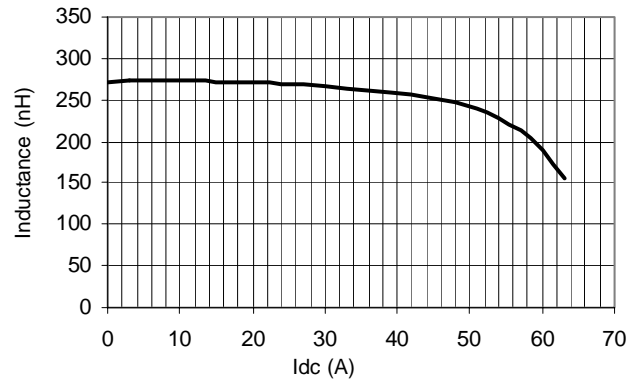

59P9883 Inductance vs. I_{dc} @ 25°C

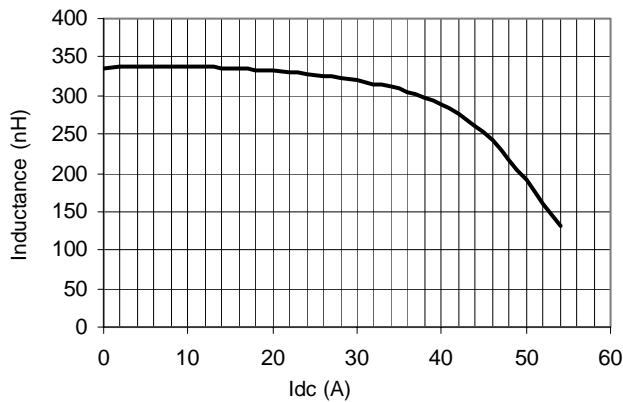

59P9884 Inductance vs. I_{dc} @ 25°C

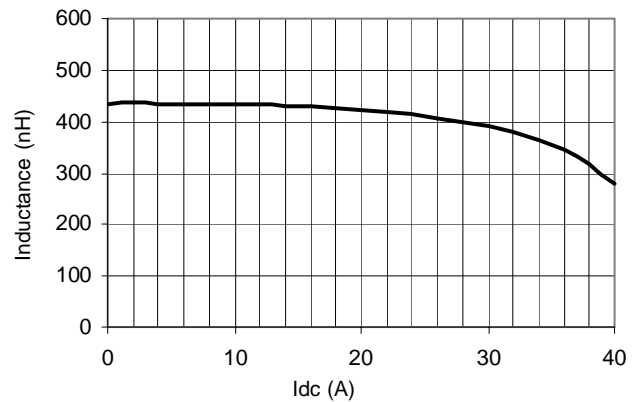

59P988x Temp. Rise vs. I_{dc}

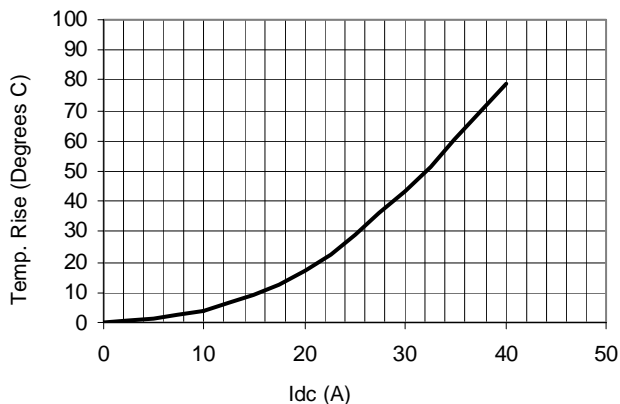

59P988x R_{dc} vs. Temp. Rise

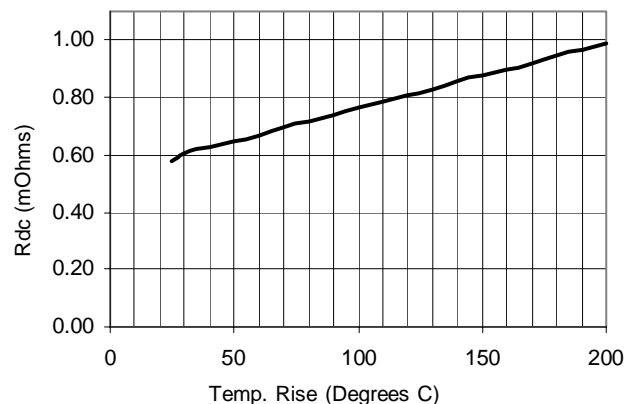

ENVIRONMENTAL & RELIABILITY DATA

Storage Temperature: -40C to +125C
 Operating Temperature: -40C to +125C
 Resistance to Solder Reflow: 3 passes thru. +235C for 30 seconds minimum

Marking permanency: Tested per JESD22-B107-A
 Solderability: Tested per MIL-STD-750D
 Life Test: Tested per MIL-STD-202F, Method 108A
 Thermal Cycle: Tested per JESD22-B104-B, Test Condition G

SMD High Frequency Power Inductor

Designed for VRM 9.x, 10.x & 11.x Applications

IR Profile

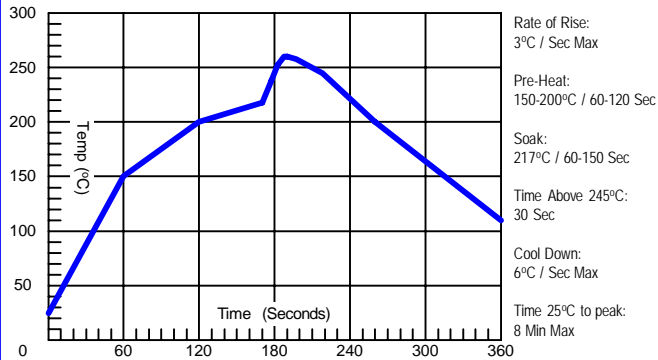

Tape and Reel

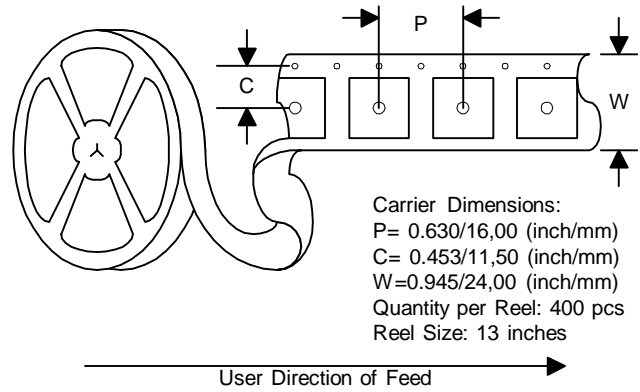

ABOUT US

Vitec Electronics Corporation, founded in 1986, is a worldwide leader in the design, manufacture and sale of magnetic solutions. Vitec's market focus includes the power, power conditioning, telecom, networking, communications and computing. Vitec has also established strong alliances with chip manufacturers whereby magnetic solutions are designed in conjunction with unique silicon requirements and are offered as reference designs by the chip companies.

With its Corporate Headquarters and Research & Development center located in Carlsbad, California, and its state of the art manufacturing facility and material sourcing in China, Vitec is uniquely positioned to supply the latest technology at the lowest cost. Vitec offers both standard and custom product design capabilities with all of its facilities being ISO certified.

QUALITY POLICY

Vitec will provide products and services that meet or exceed our Customer's requirements, conform to company policies and standards, and exhibit continuously improving levels of Quality.

COMMITMENT

VITEC Electronics empowers each of its employees by providing a business environment that encourages a commitment to excellence, a sense of ownership and personal accountability to all Vitec Customers.

Competitive Pricing, Quality Products, and On Time Deliveries are expected from today's World Class Magnetics Suppliers. The high standards of today's customer are strengthening the dedication and commitment of VITEC Electronics to provide Total Customer Service.

CONTACT US

USA

VITEC ELECTRONICS CORPORATION
6213 El Camino Real
Carlsbad, CA 92009
U.S.A.

TEL: +1 (760) 918-8831
FAX: +1 (760) 918-8840

ASIA

SHANGHAI VITEC ELECTRONICS CO., LTD.
3369 He Chuan Road
Min Hang District, Shanghai, 201103
China

TEL: +86 (21) 6446-4828
FAX: +86 (21) 6446-4865

DUAL SMT INDUCTOR

59P9891

FEATURES

- High Current Handling Capability in the Smallest Footprint and Profile.
- Up to 2 MHz Operating Frequency.
- Extended Operating Temperature Range: -40°C to 125°C.
- Robust SMD Package Capable of Handling the Most Aggressive SMT Assembly Process.

DRAWING

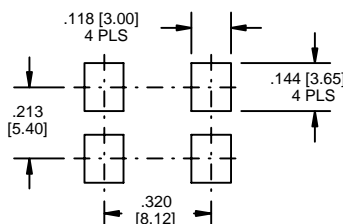
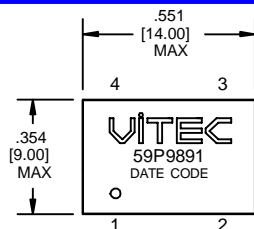

SUGGESTED PAD LAYOUT

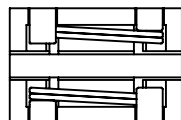
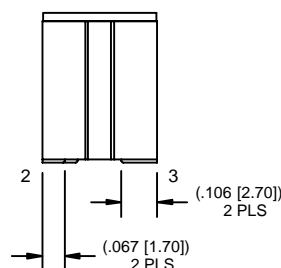
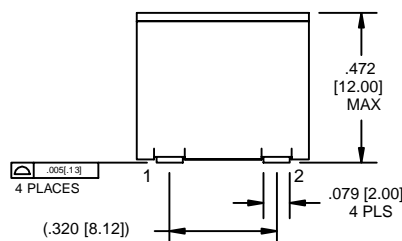

ALL DIMENSIONS GIVEN IN INCHES [MM].
TOLERANCES UNLESS OTHERWISE SPECIFIED.
LINEAR: .XX±.01 [X±.25] .XXX±.005 [XX±.13]
ANGULAR: ±1°

SCHEMATIC

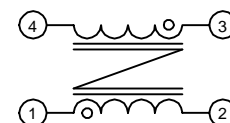

ELECTRICAL CHARACTERISTICS @ 25°C

Part Number		Inductance @ 0Adc ⁴	Inductance @ Irated ⁴	Irated ¹	DCR		MAX Saturation Current ²			Temp. Rise Current ³	Temp. Rise Factor ⁵
Classic	RoHS	nH ± 15%	nH MIN	ADC MAX	mOhms TYP MAX		ADC -40°C	ADC 25°C	ADC 125°C	ADC MAX	
59P9891	59PR9891	1000	680	27	1.6	1.8	28	27	21	21	0.06464

Add an "R" to the part number after "P" for the RoHS compliant version (i.e. 59PR9891 is the RoHS compliant version of 59P9891).

Notes:

- 1 - The rated current is the saturation current @ 25°C.
- 2 - The I(Saturation) is the current at which the inductance drops by 20% maximum of its value at 0ADC. This current is measured at the stated ambient environment and by applying a short duration pulse current to the component, minimizing the self-heating effects.
- 3 - The I(Temp. Rise) is the current at which the temperature of the part increases by a maximum of 50°C. This test is performed with the part mounted on a PCB with 0.250" wide, 0.004" thick copper traces and applying the DC current for a minimum of 30 minutes.
- 4 - Inductance is measured at 100 KHz and 1.0 Vrms.
- 5 - The additional Temperature Rise due to High ET (Voltage x Time) can be estimated using the following formula:

$$\text{Trise (}^{\circ}\text{C)} = \left(\frac{\text{Core Loss} + \text{DCR Loss}}{6.44} \right)^{0.833}$$

$$\text{DCR Loss} = \left(\text{Idc}^2 + \left(\frac{\Delta I}{2} \right)^2 \right) \times 1.60$$

$$\text{Core Loss} = 0.005131 \times (F)^{1.84} \times (\text{Temp. Rise Factor} \times \Delta I)^{2.28}$$

Δ I = Delta I across the inductor

F = Switching Frequency (kHz)

This drawing is the property of Vitec Electronics Corporation. It is not a controlled document. Therefore it is subject to change without prior notice. It's intended use is to supply preliminary information only. Duplication of all or any part of this drawing is prohibited.

AF4301D_091806

This page intentionally left blank

SMD High Frequency Power Inductor

Designed for VRM 9.x, 10.x, & 11.x Applications

FEATURES

- Recommended for use with all major Voltage Regulator ICs
- High Current handling capability in the smallest footprint & profile
- Up to 2MHz operating frequency
- Extended operating temperature range: -40°C to 125°C
- Robust SMD package capable of handling the most aggressive SMT assembly process
- RoHS compliant version available



APPLICATIONS

- VRM 9.0, 10.x, and 11.x based designs
- Multi-Phase Voltage regulator designs
- Server, Desktop, PDA, Graphics cards, Notebook computers, DDR, telecom switches and routers
- DC-DC converters, Battery powered devices, high current power supplies
- High Current NPUs in networking equipment
- Point-of-load Modules

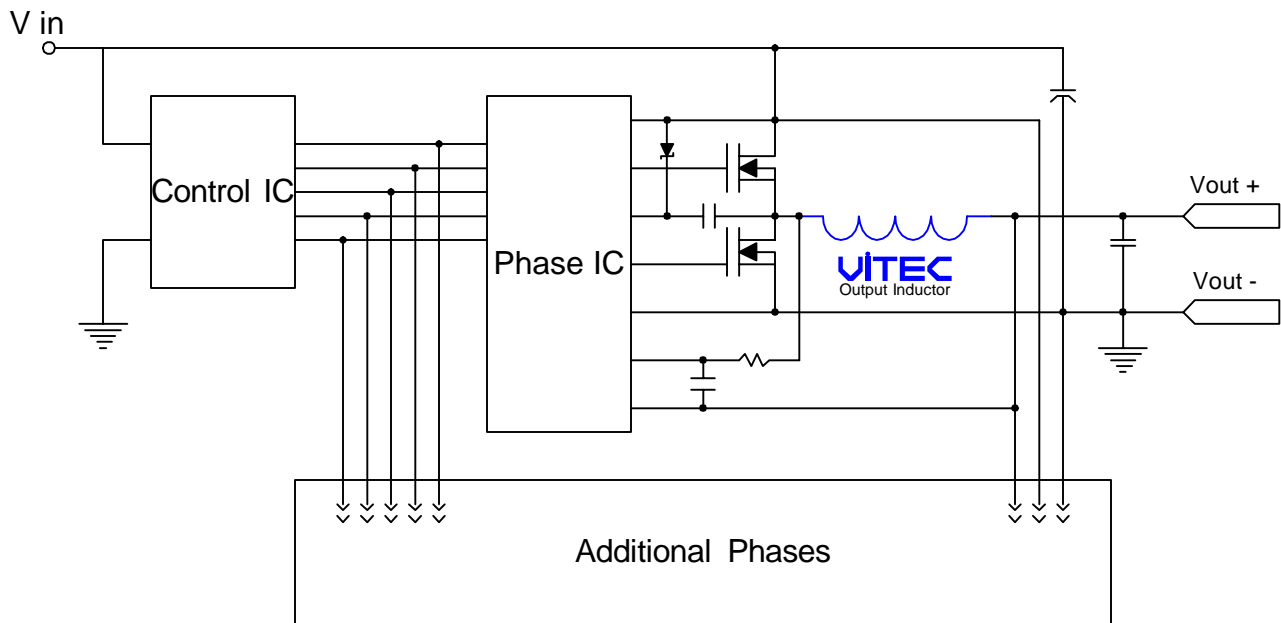

Typical Multi-Phase Application Circuit for a Buck Converter

SMD High Frequency Power Inductor

Designed for VRM 9.x, 10.x, & 11.x Applications

PACKAGE

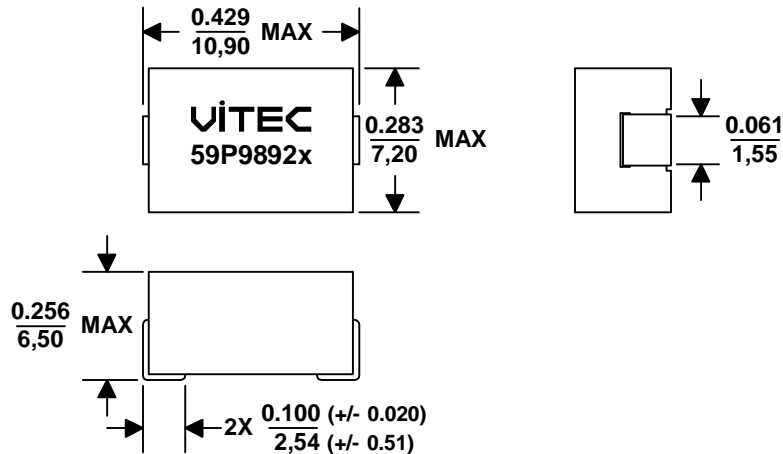

Dimensions: Inches/mm. Tolerances: +/- 0.010"/0,25mm unless otherwise noted

SCHEMATIC

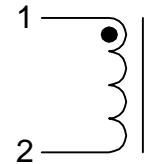

SUGGESTED PCB LAYOUT

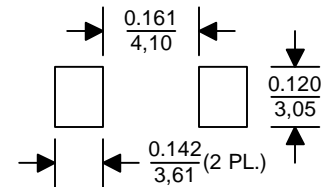

Drawing NOT to scale

ELECTRICAL CHARACTERISTICS @ 25°C (unless otherwise noted)

Part Number		Application Inductance	Inductance @ 0Adc ⁴	Inductance @ Irated ⁴	Irated ¹	DCR	Saturation Current ²			Temp. Rise Current ³	Temp. Rise Factor ⁵
Classic	RoHS	nH TYP	nH ± 15%	nH MIN	ADC MAX	mOhm +/- 8%	ADC -40°C	ADC 25°C	ADC 125°C	ADC MAX	
59P9892	59PR9892	200	200	136	42	0.550	43	42	34	33	.0413
59P9892N	59PR9892N	200	200	136	45	0.470	46	45	39	35	.0413

Add an "R" to the part number after "P" for the RoHS compliant version (i.e. 59PR9892 is the RoHS compliant version of 59P9892).

Notes:

- The rated current is the saturation current @ 25°C.
- The I(Saturation) is the current at which the inductance drops by 20% maximum of its value at 0ADC. This current is measured at the stated ambient environment and by applying a short duration pulse current to the component, minimizing the self-heating effects.
- The I(Temp. Rise) is the current at which the temperature of the part increases by a maximum of 50°C. This test is performed with the part mounted on a PCB with 0.250" wide, 0.004" thick copper traces and applying the DC current for a minimum of 30 minutes.
- Inductance is measured at 100 KHz and 1.0 Vrms.
- The additional Temperature Rise due to High ET (Voltage x Time) can be estimated using the following formula:

$$\text{Trise (}^{\circ}\text{C)} = \left(\frac{\text{Core Loss} + \text{DCR Loss}}{5.47} \right)^{0.833}$$

$$\text{DCR Loss} = \left(\text{Idc}^2 + \left(\frac{\Delta I}{2} \right)^2 \right) \times \text{NOM DCR}$$

$$\text{Core Loss} = 0.00438 \times (F)^{1.84} \times (\text{Temp. Rise Factor} \times \Delta I)^{2.28}$$

ΔI = Delta I across the inductor
F = Switching Frequency (kHz)

SMD High Frequency Power Inductor

Designed for VRM 9.x, 10.x, & 11.x Applications

59P9892 Temp. Rise vs. Idc

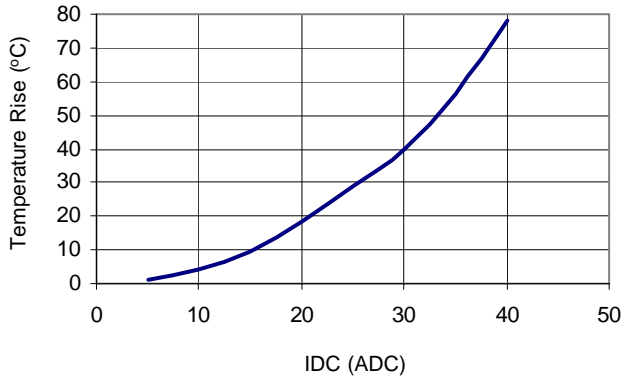

59P9892N Temp. Rise vs. Idc

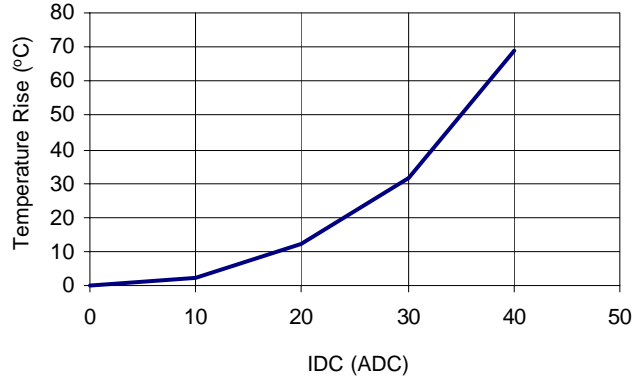

59P9892 Rdc vs. Temp. Rise

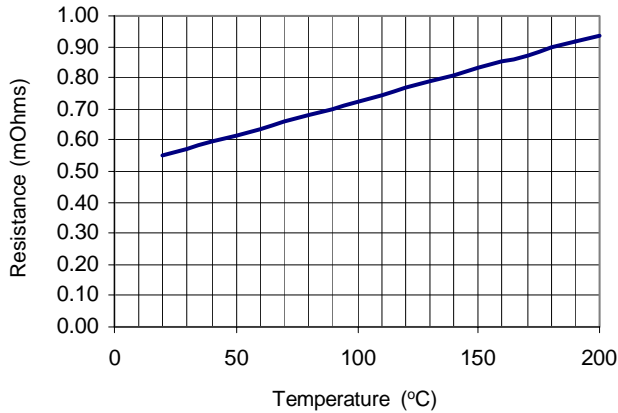

59P9892N Rdc vs. Temp. Rise

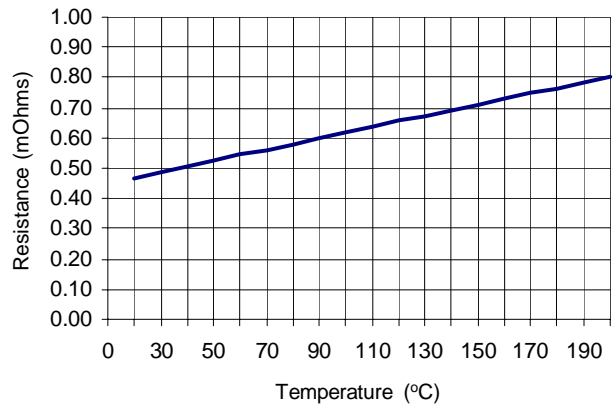

59P9892x Inductance vs. Idc @ 25°C

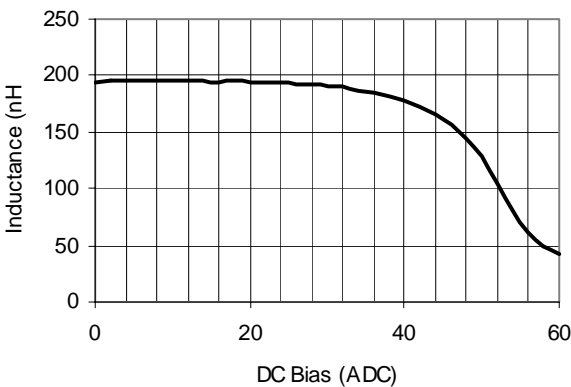

59P9892x Inductance vs. Idc @ 125°C

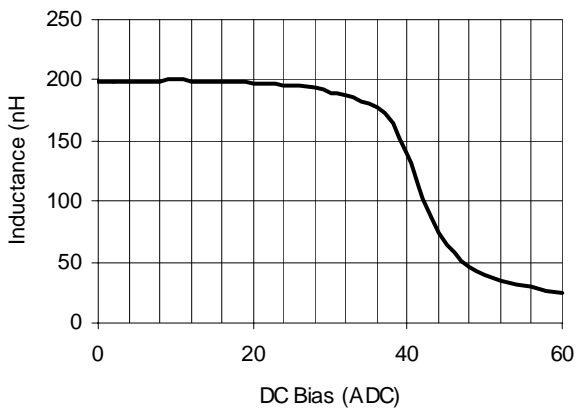

ENVIRONMENTAL & RELIABILITY DATA

Storage Temperature: -40C to +125C
 Operating Temperature: -40C to +125C
 Resistance to Solder Reflow: 3 passes thru. +235C for 30 seconds minimum

Marking permanency: Tested per JESD22-B107-A
 Solderability: Tested per JESD22-B102D
 Life Test: Tested per MIL-STD-202F, Method 108A
 Thermal Cycle: Tested per JESD22-B104-B, Test Condition G

SMD High Frequency Power Inductor

Designed for VRM 9.x, 10.x, & 11.x Applications

IR Profile

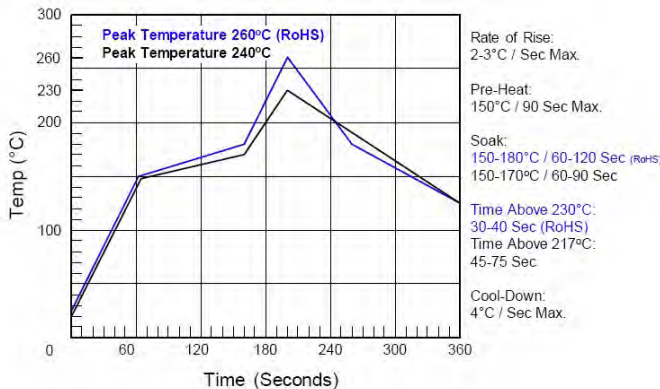

Tape and Reel

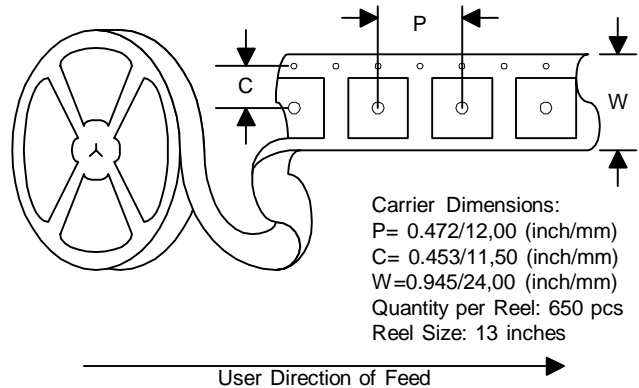

ABOUT US

Vitec Electronics Corporation, founded in 1986, is a worldwide leader in the design, manufacture and sale of magnetic solutions. Vitec's market focus includes the power, power conditioning, telecom, networking, communications and computing. Vitec has also established strong alliances with chip manufacturers whereby magnetic solutions are designed in conjunction with unique silicon requirements and are offered as reference designs by the chip companies.

With its Corporate Headquarters and Research & Development center located in Carlsbad, California, and its state of the art manufacturing facility and material sourcing in China, Vitec is uniquely positioned to supply the latest technology at the lowest cost. Vitec offers both standard and custom product design capabilities with all of its facilities being ISO certified.

QUALITY POLICY

Vitec will provide products and services that meet or exceed our Customer's requirements, conform to company policies and standards, and exhibit continuously improving levels of Quality.

COMMITMENT

VITEC Electronics empowers each of its employees by providing a business environment that encourages a commitment to excellence, a sense of ownership and personal accountability to all Vitec Customers.

Competitive Pricing, Quality Products, and On Time Deliveries are expected from today's World Class Magnetics Suppliers. The high standards of today's customer are strengthening the dedication and commitment of VITEC Electronics to provide Total Customer Service.

CONTACT US

USA

VITEC ELECTRONICS CORPORATION
6213 El Camino Real
Carlsbad, CA 92009
U.S.A.

TEL: +1 (760) 918-8831
FAX: +1 (760) 918-8840

ASIA

SHANGHAI VITEC ELECTRONICS CO., LTD.
3369 He Chuan Road
Min Hang District, Shanghai, 201103
China

TEL: +86 (21) 6446-4828
FAX: +86 (21) 6446-4865

High Freq., High Power Inductor

59P9893

FEATURES

- Designed for use in Buck Regulators.
- Operating Frequency 0.350 - 2.0 MHz.
- Operating Temperature Range of -40°C to 125°C.
- RoHS Compliant Version Available.
- Low DC Resistance for higher efficiency.

DRAWING

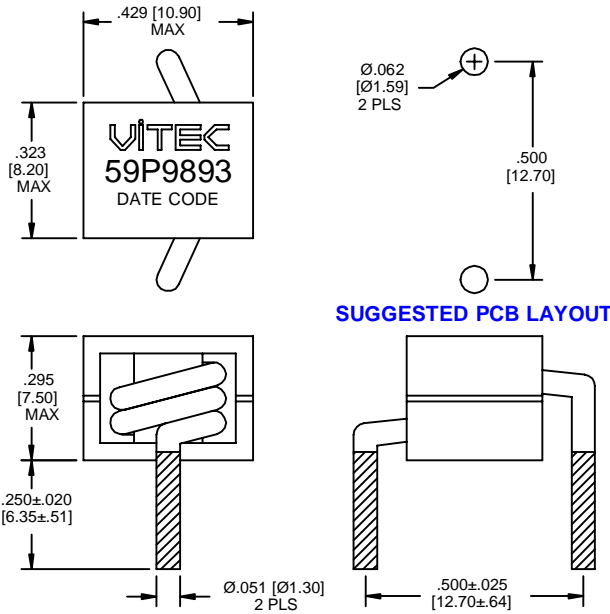

ALL DIMENSIONS GIVEN IN INCHES [MM].
TOLERANCES UNLESS OTHERWISE SPECIFIED.
XX±.01 [X±.25] XX±.004 [XX±.10] ANGULAR: ±1°

SCHEMATIC

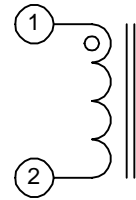

ELECTRICAL CHARACTERISTICS @ 25°C

Part Number		Application Inductance	Inductance @ 0Adc ⁴	Inductance @ Irated ⁴	Irated ¹	DCR	MAX Saturation Current ²			Temp. Rise Current ³	Temp. Rise Factor ⁵
Classic	RoHS	nH	nH ± 10%	nH MIN	ADC MAX	mOhms ±10%	ADC -40°C	ADC 25°C	ADC 125°C	ADC MAX	
59P9893	59PR9893	300	300	216	42	0.87	43	42	33	26	0.04247

Add an "R" to the part number after "P" for the RoHS compliant version (i.e. 59PR9893 is the RoHS compliant version of 59P9893).

Notes:

- 1 - The rated current is the saturation current @ 25°C.
- 2 - The I(Saturation) is the current at which the inductance drops by 20% maximum of its value at 0ADC. This current is measured at the stated ambient environment and by applying a short duration pulse current to the component, minimizing the self-heating effects.
- 3 - The I(Temp. Rise) is the current at which the temperature of the part increases by a maximum of 50°C. This test is performed with the part mounted on a PCB with 0.250" wide, 0.004" thick copper traces and applying the DC current for a minimum of 30 minutes.
- 4 - Inductance is measured at 100 KHz and 1.0 Vrms.
- 5 - The additional Temperature Rise due to High ET (Voltage x Time) can be estimated using the following formula:

$$\text{Trise (}^{\circ}\text{C)} = \left(\frac{\text{Core Loss} + \text{DCR Loss}}{5.37} \right)^{0.833}$$

$$\text{DCR Loss} = \left(\text{Idc}^2 + \left(\frac{\Delta I}{2} \right)^2 \right) \times \text{TYP DCR}$$

$$\text{Core Loss} = 0.003484 \times (F)^{1.84} \times (\text{Temp. Rise Factor} \times \Delta I)^{2.28}$$

ΔI = Delta I across the inductor

F = Switching Frequency (kHz)

This drawing is the property of Vitec Electronics Corporation. It is not a controlled document. Therefore it is subject to change without prior notice. Its intended use is to supply preliminary information only. Duplication of all or any part of this drawing is prohibited.

AF3933_091306

This page intentionally left blank

SMD High Frequency Power Inductor

Designed for Utility Regulator Applications

FEATURES

- Recommended for use with all major Voltage Regulator ICs
- High Current handling capability in the smallest footprint
- Up to 2MHz operating frequency
- Extended operating temperature range: -40C to 125C
- Robust SMD package capable of handling the most aggressive SMT assembly process
- RoHS compliant version available

APPLICATIONS

- Powering Utility Regulator functions such as input/output (I/O), memory and application-specific integrated circuit (ASICs).
- Server, Desktop, PDA, Graphics cards, Notebook computers, DDR, telecom switches and routers
- DC-DC converters, Battery powered devices, high current power supplies
- High Current NPUs in networking equipment
- Point-of-load Modules
- DCR sensing

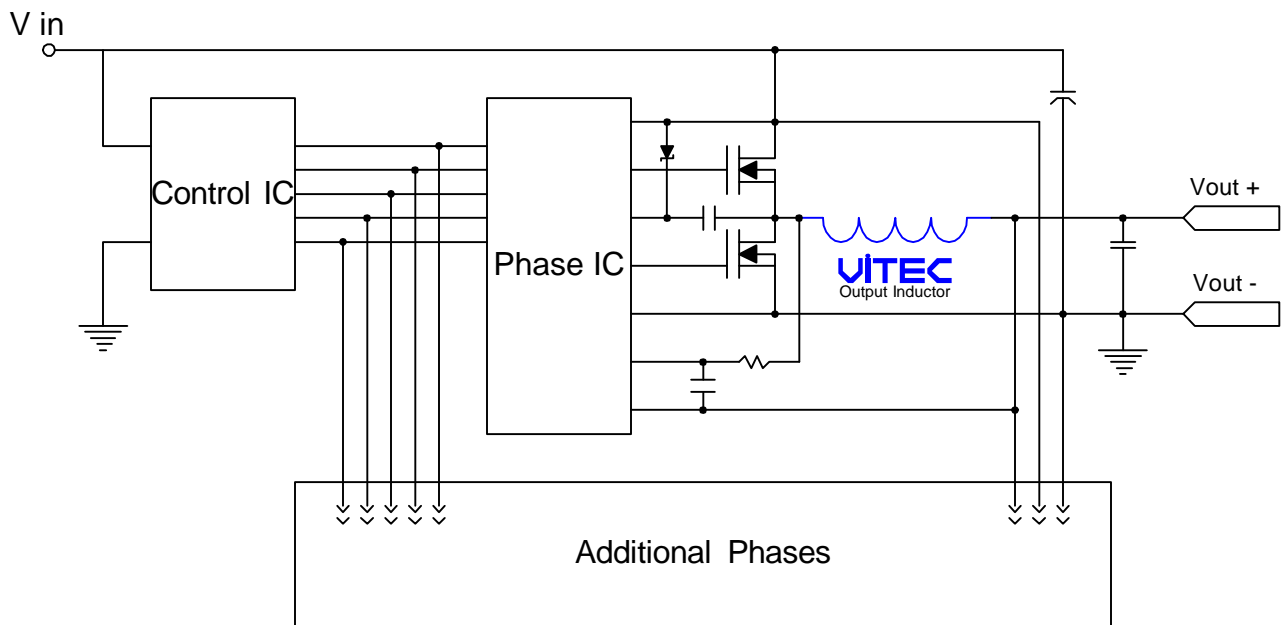

Typical Multi-Phase Application Circuit for a Buck Converter

SMD High Frequency Power Inductor

Designed for Utility Regulator Applications

PACKAGE

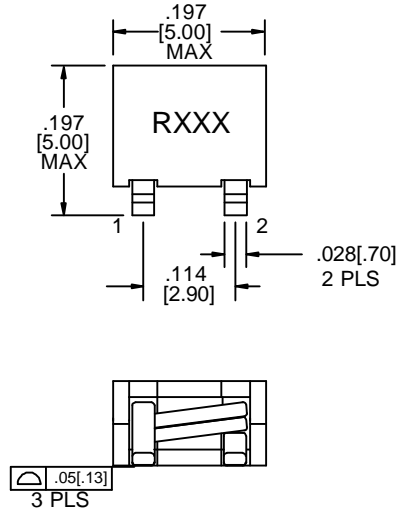

FIG. 2

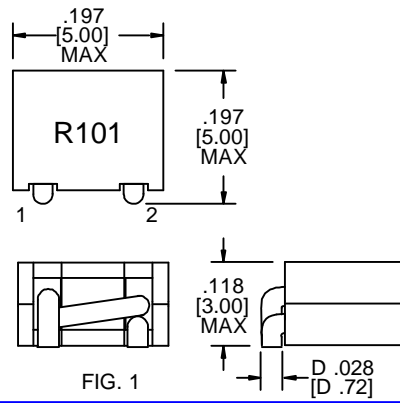

FIG. 1

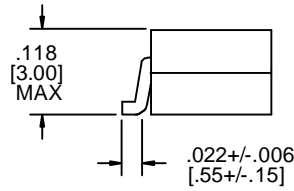
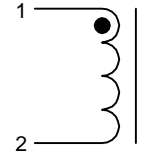

FIG. 2

Dimensions: Inches/mm. Tolerances: +/- 0.008"/0.20mm unless otherwise noted

SCHEMATIC



SUGGESTED PCB LAYOUT

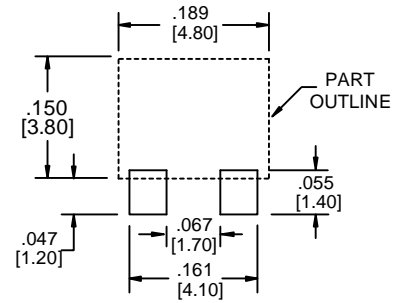

Drawing NOT to scale

ELECTRICAL CHARACTERISTICS @ 25°C (unless otherwise noted)

Part Number	FIG	Inductance @ 0Adc ⁴	Inductance @ Irated ⁴	Irated ¹	DCR		MAX Saturation Current ²			Temp. Rise Current ³	Temp. Rise Factor ⁵	
		nH	nH	ADC	mOhm		ADC			ADC	A	B
		± 10%	MIN	MAX	TYP	MAX	-40°C	25°C	125°C	MAX		
59PR21-101	1	100	72	23.0	0.9	1.0	23.5	23.0	18.0	15.0	0.07200	1.05
59PR21-201	2	200	144	15.0	2.0	2.5	18.0	17.5	13.5	8.0	0.09466	1.17
59PR21-331	2	330	238	10.5	2.0	2.5	11.0	10.5	8.2	8.0	0.15851	1.17
59PR21-471	2	470	338	10.0	3.7	4.3	10.5	10.0	7.8	6.3	0.16878	1.34
59PR21-681	2	680	490	6.8	3.7	4.1	6.9	6.8	5.3	6.3	0.24419	1.34
59PR21-102	2	1000	680	5.7	5.5	6.1	6.0	5.8	4.5	5.5	0.28785	1.52

Notes:

- The rated current is the saturation current @ 25°C.
- The I(Saturation) is the current at which the inductance drops by 20% maximum of its value at 0ADC. This current is measured at the stated ambient environment and by applying a short duration pulse current to the component, minimizing the self-heating effects.
- The I (Temp. Rise) is the current at which the temperature of the part increases by a maximum of 50°C. This test is performed with the part mounted on a PCB with 0.250" wide, 0.004" thick copper traces and applying the DC current for a minimum of 30 minutes.
- Inductance is measured at 100 KHz and 1.0 Vrms.
- Temperature Rise can be estimated using the following formulas:

$$\text{Trise (}^{\circ}\text{C)} = \left(\frac{\text{Core Loss} + \text{DCR Loss}}{B} \right)^{0.833}$$

$$\text{DCR Loss (mW)} = \left(I_{dc}^2 + \left(\frac{\Delta I}{2} \right)^2 \right) \times \text{TYP DCR (mOhms)}$$

$$\text{Core Loss (mW)} = 0.00224 \times (F)^{1.84} \times (\text{Temp. Rise factor} \times \Delta I)^{2.2}$$

IDC = DC output current (ADC)
 ΔI = Delta I across the inductor (Amps)
 F = Switching frequency (kHz)

SMD High Frequency Power Inductor

Designed for Utility Regulator Applications

59P21-101 Inductance vs. I_{dc} @ 25°C

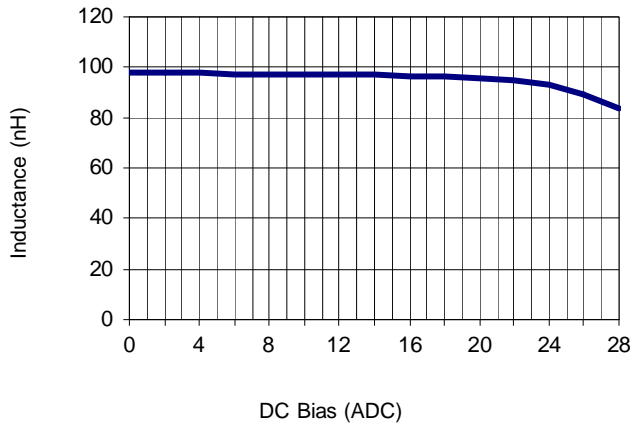

59P21-201 Inductance vs. I_{dc} @ 25°C

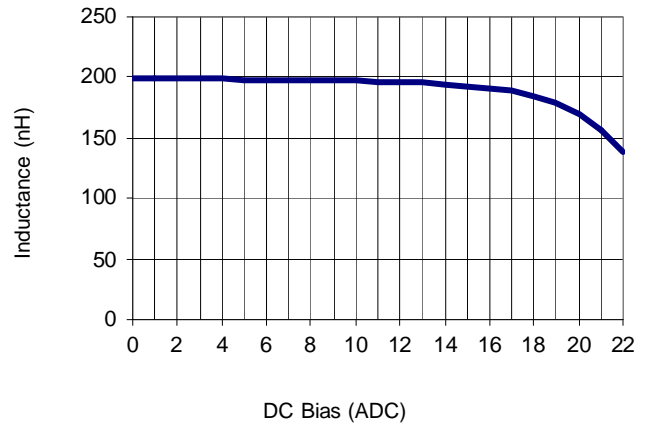

59P21-331 Inductance vs. I_{dc} @ 25°C

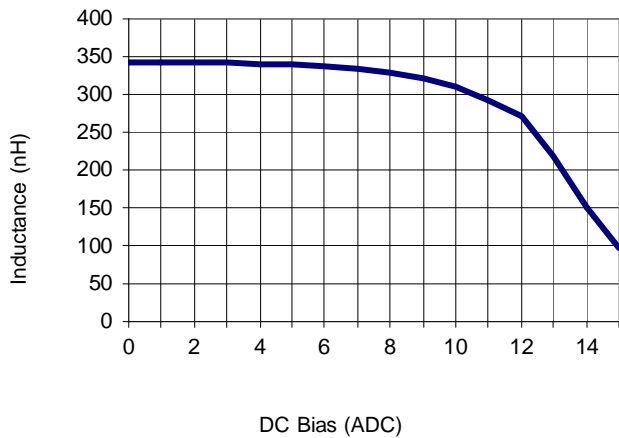

59P21-471 Inductance vs. I_{dc} @ 25°C

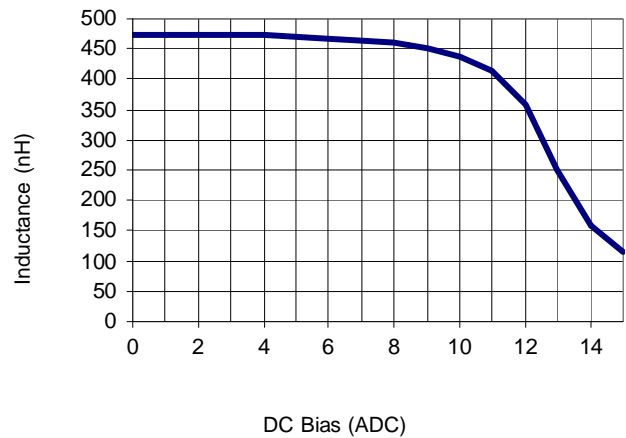

59P21-681 Inductance vs. I_{dc} @ 25°C

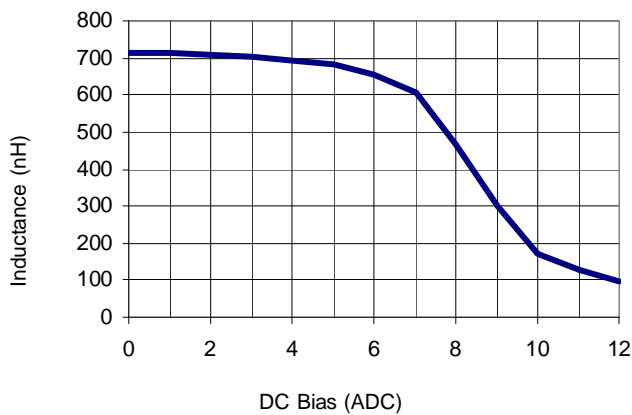

59P21-102 Inductance vs. I_{dc} @ 25°C

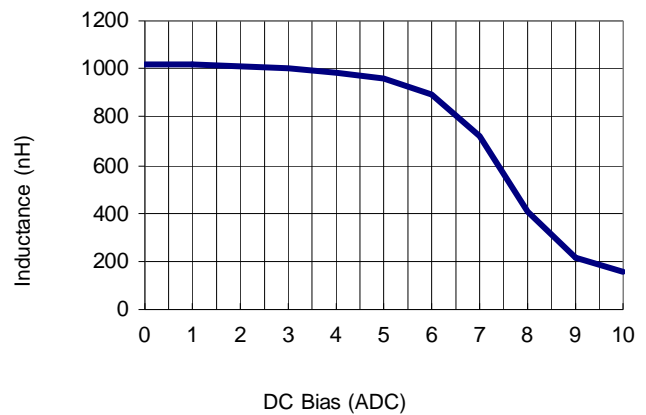

SMD High Frequency Power Inductor

Designed for Utility Regulator Applications

59P21-101 Temp. Rise vs. Idc

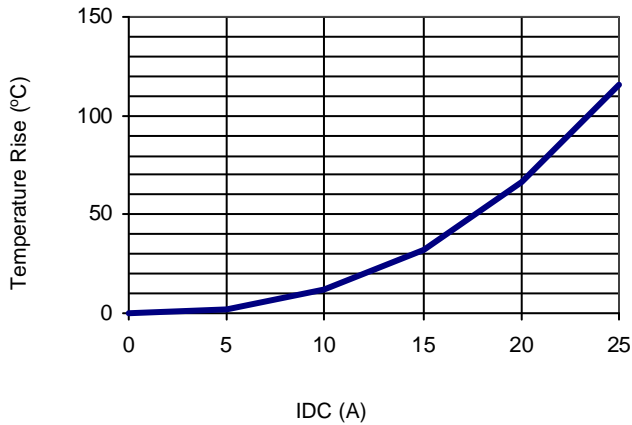

59P21-201 Temp. Rise vs. Idc

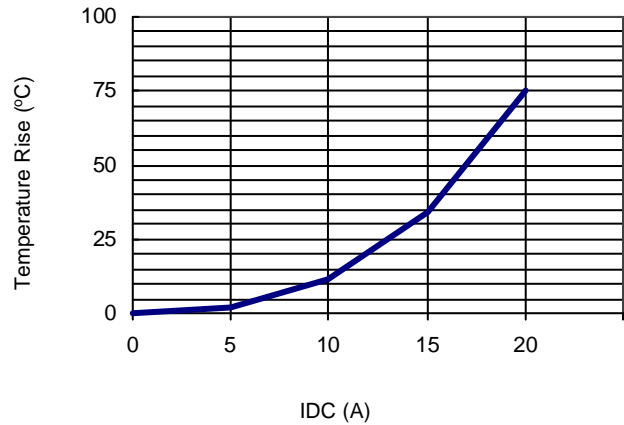

59P21-331 Temp. Rise vs. Idc

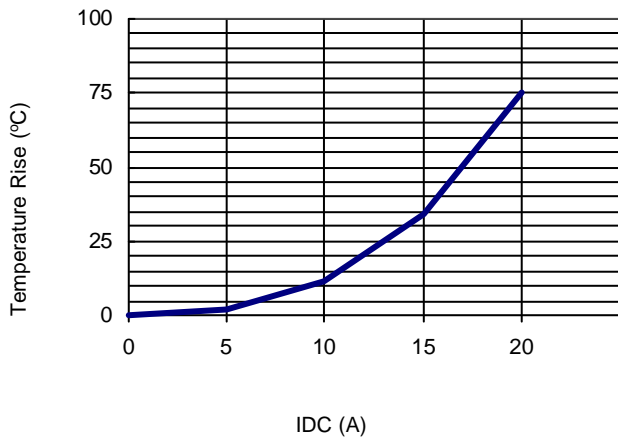

59P21-471 Temp. Rise vs. Idc

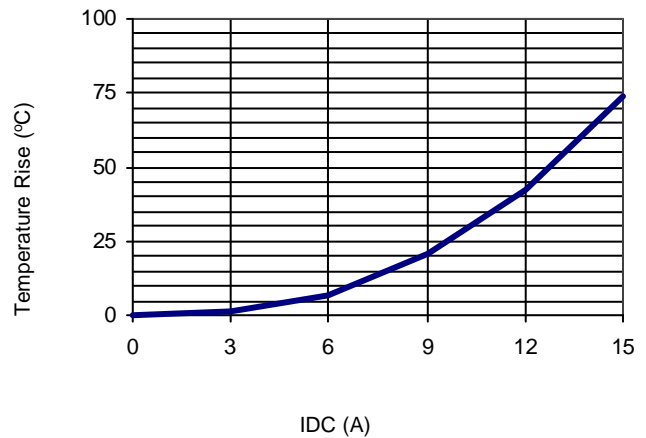

59P21-681 Temp. Rise vs. Idc

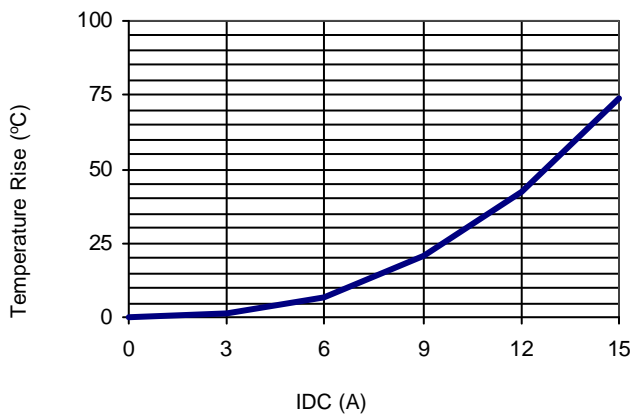

59P21-102 Temp. Rise vs. Idc

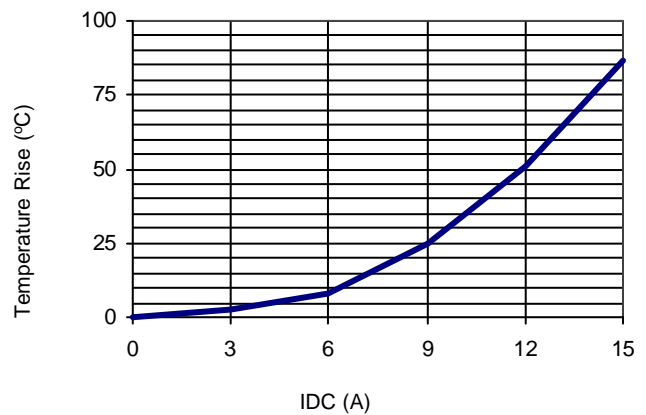

SMD High Frequency Power Inductor

Designed for Utility Regulator Applications

59P21-101 Rdc vs. Temp. Rise

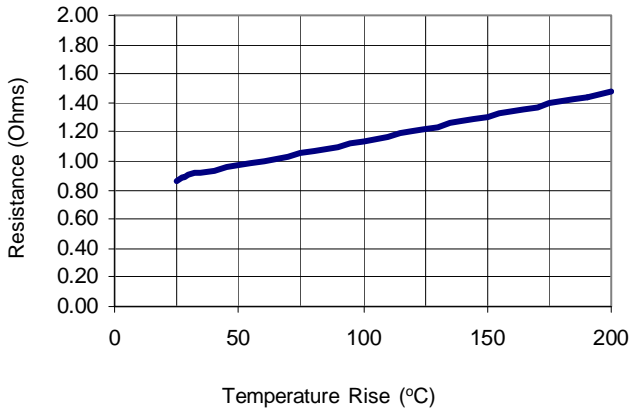

59P21-201 Rdc vs. Temp. Rise

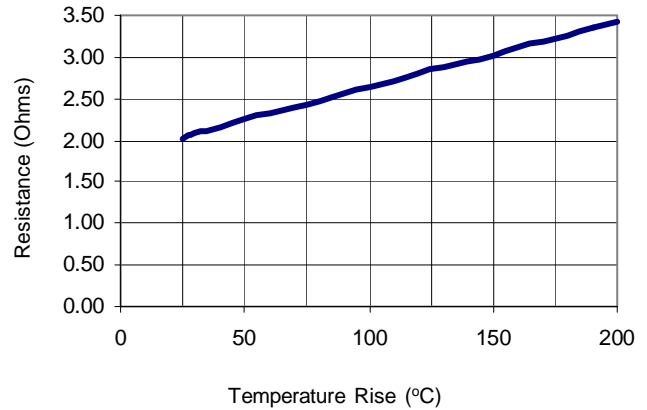

59P21-331 Rdc vs. Temp. Rise

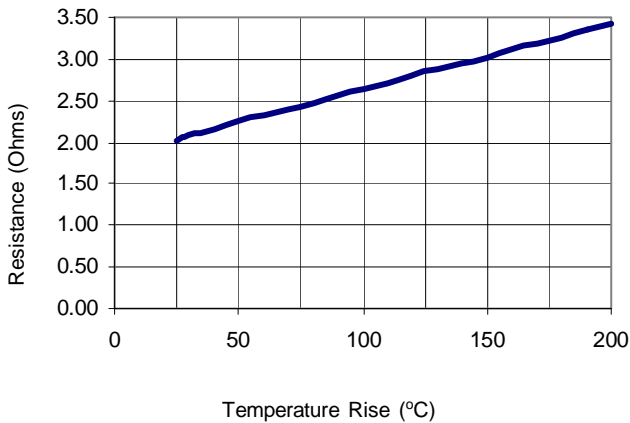

59P21-471 Rdc vs. Temp. Rise

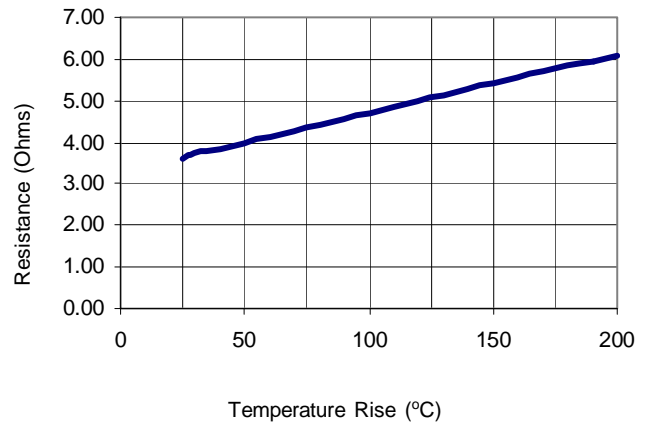

59P21-681 Rdc vs. Temp. Rise

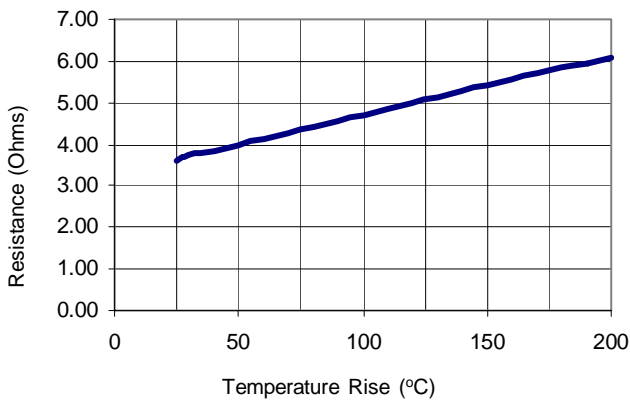

59P21-102 Rdc vs. Temp. Rise

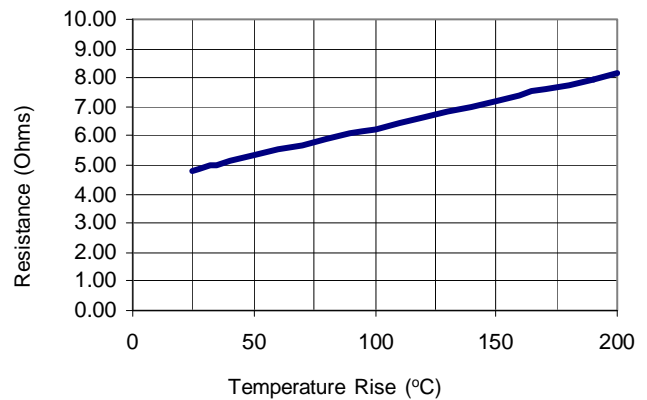

SMD High Frequency Power Inductor

Designed for Utility Regulator Applications

IR Profile

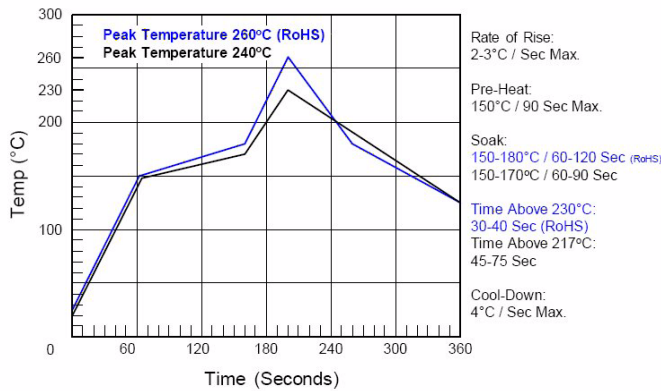

Tape and Reel

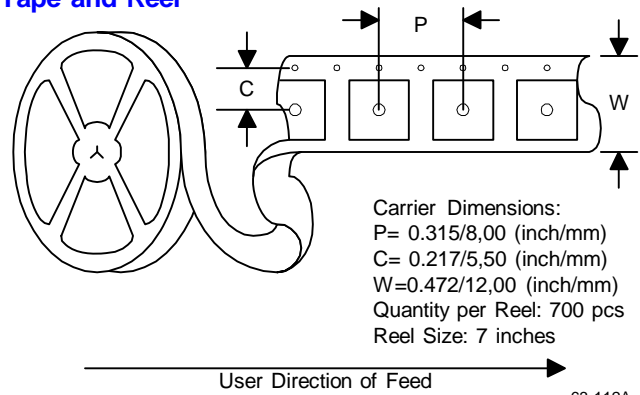

ENVIRONMENTAL & RELIABILITY DATA

Storage Temperature: -40C to +125C
Operating Temperature: -40C to +125C
Resistance to Solder Reflow: 3 passes thru. +235C for 30 seconds minimum

Marking permanency: Tested per JESD22-B107-A
Solderability: Tested per MIL-STD-750D
Life Test: Tested per MIL-STD-202F, Method 108A
Thermal Cycle: Tested per JESD22-B104-B, Test Condition G

ABOUT US

Vitec Electronics Corporation, founded in 1986, is a worldwide leader in the design, manufacture and sale of magnetic solutions. Vitec's market focus includes the power, power conditioning, telecom, networking, communications and computing. Vitec has also established strong alliances with chip manufacturers whereby magnetic solutions are designed in conjunction with unique silicon requirements and are offered as reference designs by the chip companies.

With its Corporate Headquarters and Research & Development center located in Carlsbad, California, and its state of the art manufacturing facility and material sourcing in China, Vitec is uniquely positioned to supply the latest technology at the lowest cost. Vitec offers both standard and custom product design capabilities with all of its facilities being ISO certified.

QUALITY POLICY

Vitec will provide products and services that meet or exceed our Customer's requirements, conform to company policies and standards, and exhibit continuously improving levels of Quality.

COMMITMENT

VITEC Electronics empowers each of its employees by providing a business environment that encourages a commitment to excellence, a sense of ownership and personal accountability to all Vitec Customers.

Competitive Pricing, Quality Products, and On Time Deliveries are expected from today's World Class Magnetics Suppliers. The high standards of today's customer are strengthening the dedication and commitment of VITEC Electronics to provide Total Customer Service.

CONTACT US

USA

VITEC ELECTRONICS CORPORATION
6213 El Camino Real
Carlsbad, CA 92009
U.S.A.

TEL: +1 (760) 918-8831
FAX: +1 (760) 918-8840

ASIA

SHANGHAI VITEC ELECTRONICS CO., LTD.
3369 He Chuan Road
Min Hang District, Shanghai, 201103
China

TEL: +86 (21) 6446-4828
FAX: +86 (21) 6446-4865

High Frequency Power Inductor

59PR31-XXX

FEATURES

- Designed for use in VRM Applications.
- Operating Frequency 0.100 - 2.0 MHz.
- Operating Temperature Range of -40°C to 125°C.
- RoHS Compliant Version Available.
- Surface Mount Package for pick and place assembly.

DRAWING

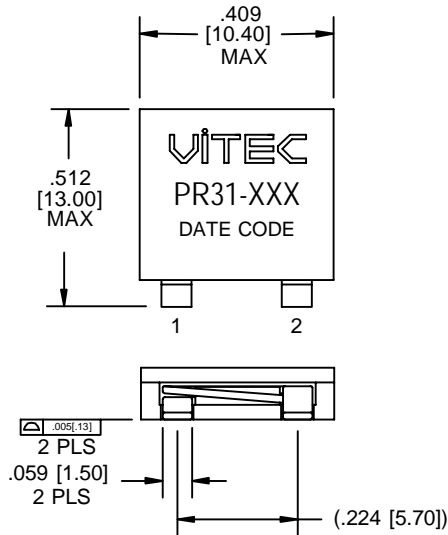

PRELIMINARY

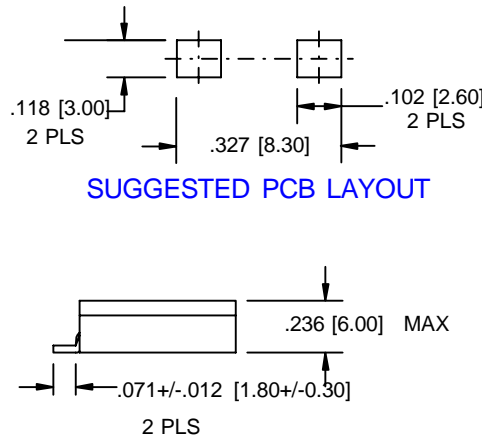

SCHEMATIC

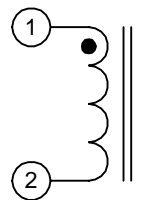

ALL DIMENSIONS GIVEN IN INCHES [MM].
TOLERANCES UNLESS OTHERWISE SPECIFIED.
.XX+/.01 [X+0.25] .XXX+/.005 [XX+0.13]
ANGULAR: +/-°

ELECTRICAL CHARACTERISTICS @ 25°C

Part Number	Inductance ⁴ @ 0 Adc	Inductance ⁴ @ Irated ¹	Inductance ⁴ @ Isat ²	Irated ¹	Isat ²	DCR	MAX Saturation Current ²			Temp. Rise Current ³	Temp. Rise Factor A (TRF A) ⁵	Temp. Rise Factor B (TRF B) ⁵	Temp. Rise Factor C (TRF C) ⁵	
							ADC	ADC	ADC					
Classic	RoHS	nH +/-10%	nH TYP	nH MIN	ADC MAX	ADC MAX	mOhms +/-10%	ADC -40°C	ADC 25°C	ADC 125°C	ADC MAX			
59P31-721	59PR31-721	720	580	550	TBD	35	0.90	36	35	26	TBD	TBD	TBD	TBD

Add an "R" to the part number after "P" for the RoHS compliant version (i.e. 59PR31-721 is the RoHS compliant version of 59P31-721).

Notes:

- 1 - The Rated Current (Irated) is either the Saturation Current at 25°C or the Temperature Rise Current ; the lowest number of the two specified currents.
- 2 - The Saturation Current (Isat) is the current at which the Inductance drops by a maximum of 20% below the lower limit of its value specified at 0 ADC Bias. Inductance at Isat is measured at the specified Ambient Temperature by applying DC Bias by a short period of time to minimize the self-heating effect of the component.
- 3 - The Temperature Rise Current is the current at which the temperature of the part increases by 50°C. This test is performed with the part mounted on a PCB with traces having 1.7 times the cross sectional area of the copper leads of the part. The temperature of the part is measured after applying the DC current for a minimum of 10 minutes.
- 4 - Inductance is measured at 100 KHz and 1.0 Vrms.
- 5 - Temperature Rise can be estimated using the following formulas:

$$\text{Trise (}^\circ\text{C)} = \left(\frac{\text{Core Loss} + \text{DCR Loss}}{\text{TRF A}} \right)^{0.833}$$

$$\text{DCR Loss (mW)} = \left(\text{IDC}^2 + \left(\frac{\Delta I}{2} \right)^2 \right) \times \text{TYP DCR (mOhms)}$$

$$\text{Core Loss (mW)} = \text{TRF B} \times (\text{F})^{1.84} \times (\text{TRF C} \times \Delta I)^{2.28}$$

IDC = DC Output Current (ADC)

ΔI = Delta I across the inductor (Amps)

F = Switching Frequency (kHz)

This drawing is the property of Vitec Electronics Corporation. It is not a controlled document. Therefore it is subject to change without prior notice. It's intended use is to supply preliminary information only. Duplication of all or any part of this drawing is prohibited.

This page intentionally left blank

High Frequency Power Inductor

59PR32-XXX

FEATURES

- Designed for use in VRM Applications.
- Operating Frequency 0.100 - 2.0 MHz.
- Operating Temperature Range of -40°C to 125°C.
- RoHS Compliant Version Available.
- Surface Mount Package for pick and place assembly.

DRAWING

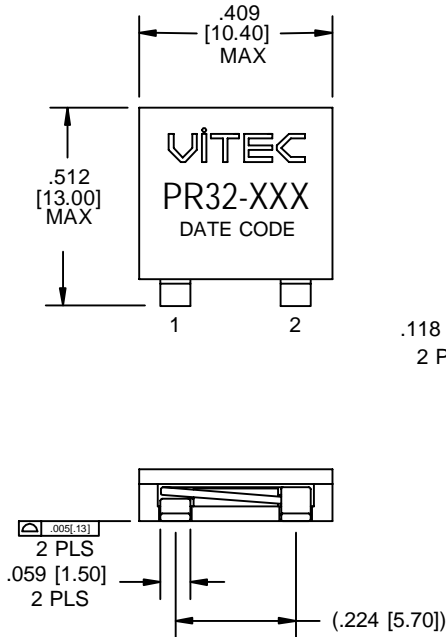

Preliminary

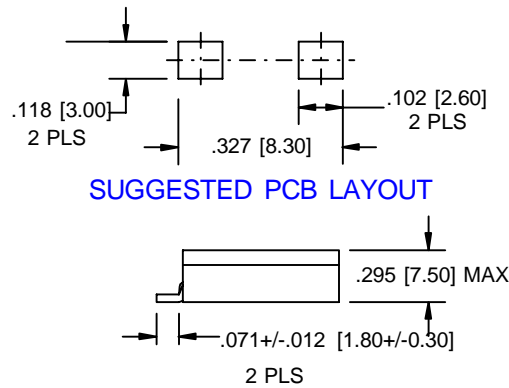

SCHEMATIC

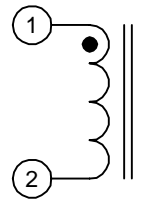

ALL DIMENSIONS GIVEN IN INCHES [MM].
TOLERANCES UNLESS OTHERWISE SPECIFIED.
.XX±.01 [X±.25] .XXX±.005 [XX±.13] ANGULAR: ±1°

PACKAGE TYPE: ER13

ELECTRICAL CHARACTERISTICS @ 25°C

Part Number		Inductance ⁴ @ 0 Adc	Inductance ⁴ @ Irated ¹	Inductance ⁴ @ Isat ²	Irated ¹	Isat ²	DCR	MAX Saturation Current ²			Temp. Rise Current ³	Temp. Rise Factor A (TRF A) ⁵	Temp. Rise Factor B (TRF B) ⁵	Temp. Rise Factor C (TRF C) ⁵
Classic	RoHS	nH	nH	nH	ADC	ADC	mOhms	ADC	ADC	ADC	ADC			
		TYP	MIN	MAX	MAX	MAX	+/-10%	-40°C	25°C	125°C	MAX			
59P32-102	59PR32-102	1000	790	720	33	33	1.5	34	33	26	26	8.64	0.007173	0.05899

Add an "R" to the part number after "P" for the RoHS compliant version (i.e. 59PR31-721 is the RoHS compliant version of 59P31-721).

Notes:

- 1 - The Rated Current (Irated) is either the Saturation Current at 25°C or the Temperature Rise Current ; the lowest number of the two specified currents.
- 2 - The Saturation Current (Isat) is the current at which the Inductance drops by a maximum of 20% below the lower limit of its value specified at 0 ADC Bias. Inductance at Isat is measured at the specified Ambient Temperature by applying DC Bias by a short period of time to minimize the self-heating effect of the component.
- 3 - The Temperature Rise Current is the current at which the temperature of the part increases by 50°C. This test is performed with the part mounted on a PCB with traces having 1.7 times the cross sectional area of the copper leads of the part. The temperature of the part is measured after applying the DC current for a minimum of 10 minutes.
- 4 - Inductance is measured at 100 KHz and 1.0 Vrms.
- 5 - Temperature Rise can be estimated using the following formulas:

$$Trise (^{\circ}C) = \left(\frac{Core Loss + DCR Loss}{TRF A} \right)^{0.833}$$

$$DCR Loss (mW) = (IDC2 + \left(\frac{\Delta I}{2}\right)^2) \times TYP DCR (mOhms)$$

$$Core Loss (mW) = TRF B \times (F)^{1.84} \times (TRF C \times \Delta I)^{2.28}$$

IDC = DC Output Current (ADC)

ΔI = Delta I across the inductor (Amps)

F = Switching Frequency (kHz)

This drawing is the property of Vitec Electronics Corporation. It is not a controlled document. Therefore it is subject to change without prior notice. It's intended use is to supply preliminary information only. Duplication of all or any part of this drawing is prohibited.

59PR32-XXX AFS0183-013008
AS0183 12/07

This page intentionally left blank

SMD High Frequency Power Inductor

Designed for VRD & VRM 10.x & 11.x Applications

FEATURES

- Designed for use in VRM 9.x, 10.x, & 11.x applications.
- Operating frequency 0.1 - 2.0 MHz.
- Operating temperature range: -40°C to 125°C.
- RoHS compliant version available.
- Surface mount package for pick and place assembly.

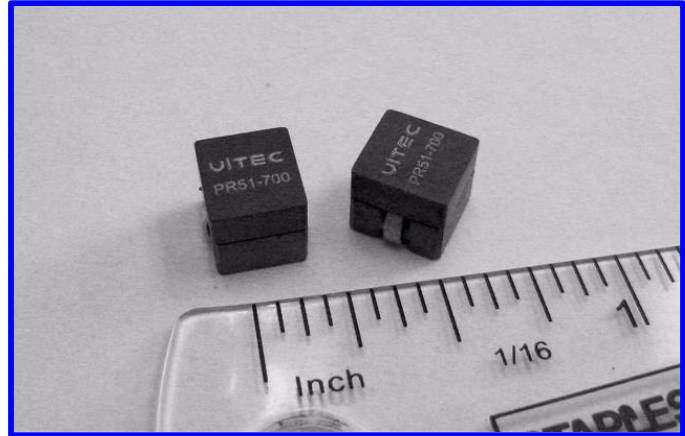

APPLICATIONS

- VRD and VRM 10.x and 11.x based designs
- Multi-Phase Voltage regulator designs
- Server, Desktop, PDA, Graphics cards, Notebook computers, DDR, telecom switches and routers
- DC-DC converters, Battery powered devices, high current power supplies
- High Current NPUs in networking equipment
- Point-of-load Modules
- DCR sensing

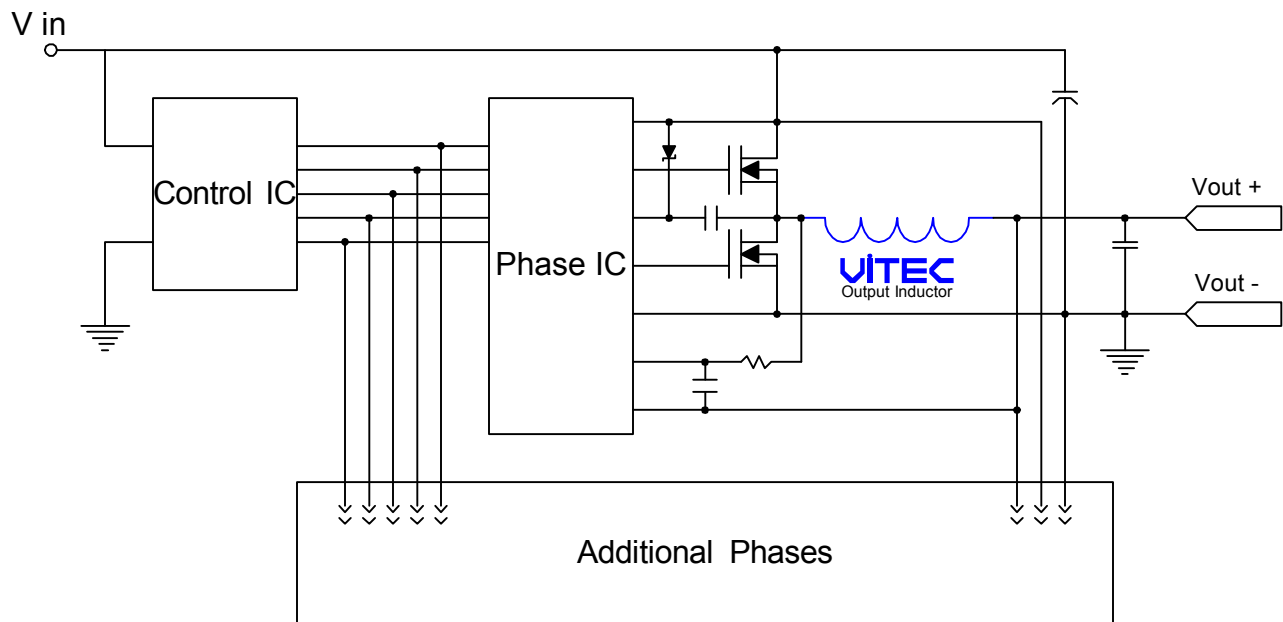

Typical Multi-Phase Application Circuit for a Buck Converter

SMD High Frequency Power Inductor

Designed for VRD & VRM 10.x & 11.x Applications

PACKAGE

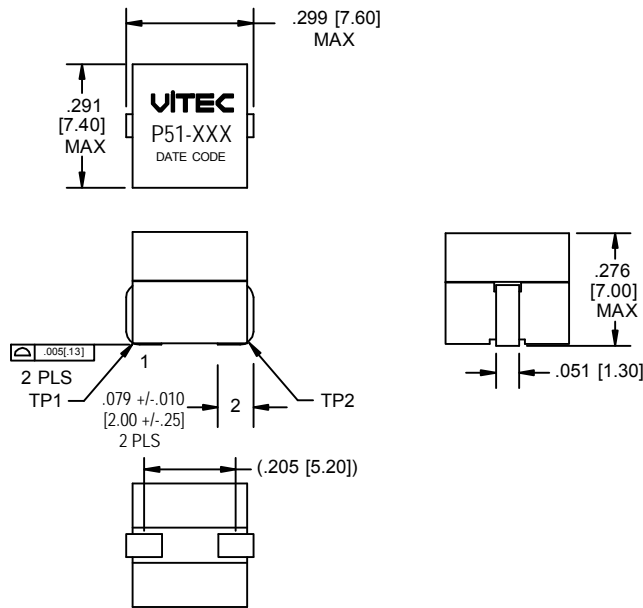

SCHEMATIC

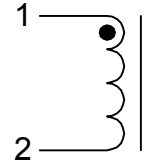

SUGGESTED PCB LAYOUT

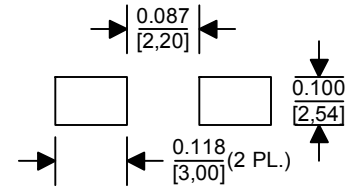

Dimensions: Inches [mm]. Tolerances unless otherwise specified. .xx +/- .01 [x +/- .25] .xxx +/- .005 [xx +/- .13] Angular +/- 1°

Drawing NOT to scale

ELECTRICAL CHARACTERISTICS @ 25°C (unless otherwise noted)

Part Number		Inductance ³ @ 0 Adc	Inductance ³ @ Isat ¹ (25°C)	DCR ⁵	Isat ¹ (Max Saturation Current)			Temp. Rise Current ²	Temp. Rise Factor A (TRF A) ⁴	Temp. Rise Factor B (TRF B) ⁴	Temp. Rise Factor C (TRF C) ⁴
		nH	nH		mOhms	ADC					
Classic	RoHS	± 15%	MIN	± 8%	25°C	100°C	125°C	MAX			
59P51-700	59PR51-700	70	48	0.55	85	72	67	26	3.39	0.002737	0.01944
59P51-101	59PR51-101	100	68	0.55	60	51	47	26	3.39	0.002693	0.02788
59P51-121	59PR51-121	120	82	0.55	50	42	39	26	3.39	0.002679	0.03349
59P51-151	59PR51-151	150	102	0.55	40	34	32	26	3.39	0.002664	0.04190
59P51-181	59PR51-181	180	122	0.55	33	28	26	26	3.39	0.002657	0.05030
59P51-221	59PR51-221	220	150	0.55	27	23	22	26	3.39	0.002649	0.06150

Add an "R" to the part number after "P" for the RoHS compliant version (i.e. 59PR51-700 is the RoHS compliant version of 59P51-700).

- The Saturation Current (Isat) is the current at which the Inductance drops by a maximum of 20% below the lower limit of its value specified at 0 ADC Bias. Inductance at Isat is measured at the specified Ambient Temperature by applying DC Bias by a short period of time to minimize the self-heating effect of the component.
- The Temperature Rise Current is the current at which the temperature of the part increases by 50°C. This test is performed with the part mounted on a PCB with traces having 1.75 times the cross sectional area of the copper leads of the part. The temperature of the part is measured after applying the DC current for a minimum of 10 minutes.
- Inductance is measured at 100 KHz and 1.0 Vrms.
- Temperature Rise can be estimated using the provided formulas.
- DCR is measured at test points (TP1-TP2).

$$\text{Trise (°C)} = \left(\frac{\text{Core Loss} + \text{DCR Loss}}{\text{TRF A}} \right)^{0.833}$$

$$\text{DCR Loss (mW)} = \left(I_{dc}^2 + \left(\frac{\Delta I}{2} \right)^2 \right) \times \text{NOM DCR (mOhms)}$$

$$\text{Core Loss (mW)} = \text{TRF B} \times (F)^{1.84} \times (\text{TRF C} \times \Delta I)^{2.28}$$

IDC = DC output current (ADC)
 ΔI = Delta I across the inductor (Amps)
 F = Switching frequency (kHz)

SMD High Frequency Power Inductor

Designed for VRD & VRM 10.x & 11.x Applications

59P51-700 Inductance vs. I_{dc} @ 25°C

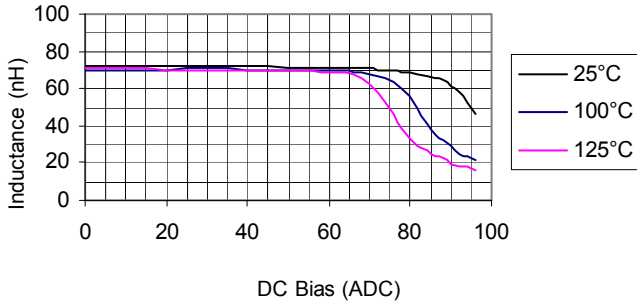

59P51-101 Inductance vs. I_{dc} @ 25°C

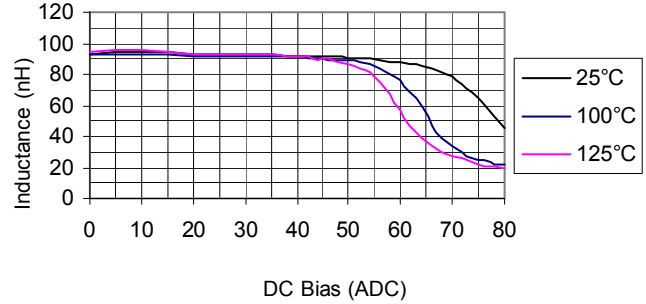

59P51-121 Inductance vs. I_{dc} @ 25°C

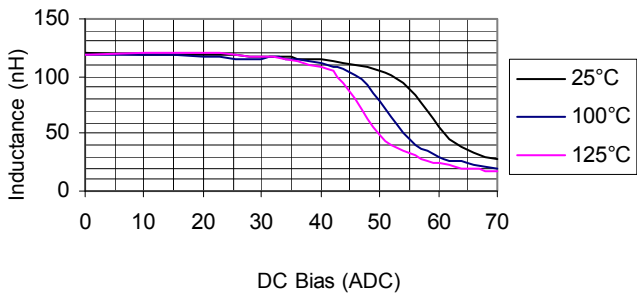

59P51-151 Inductance vs. I_{dc} @ 25°C

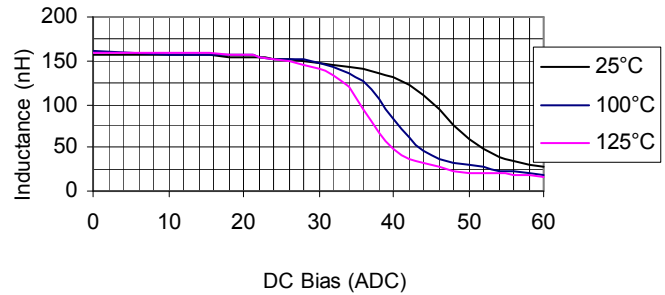

59P51-181 Inductance vs. I_{dc} @ 25°C

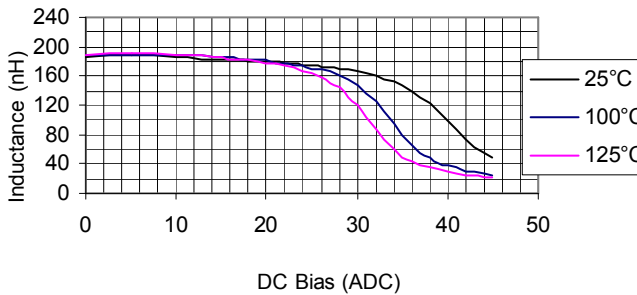

59P51-221 Inductance vs. I_{dc} @ 25°C

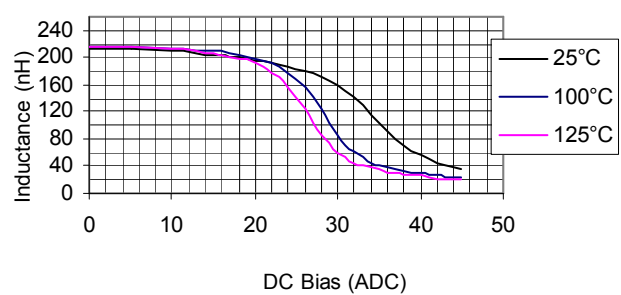

59P51-xxx Temp. Rise vs. I_{dc}

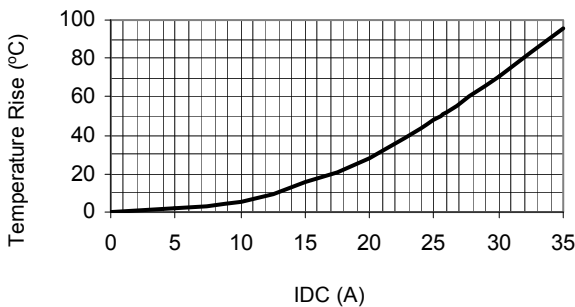

59P51-xxx R_{dc} vs. Temp. Rise

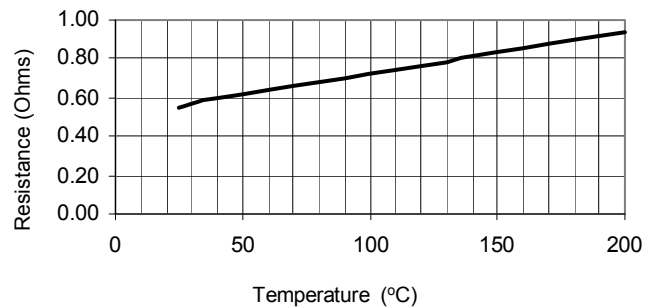

SMD High Frequency Power Inductor

Designed for VRD & VRM 10.x & 11.x Applications

IR Profile

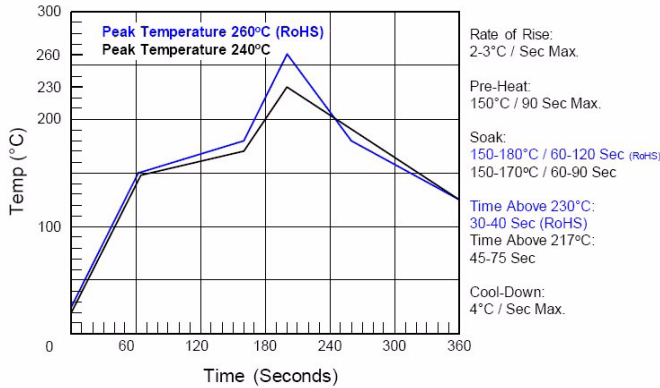

Tape and Reel

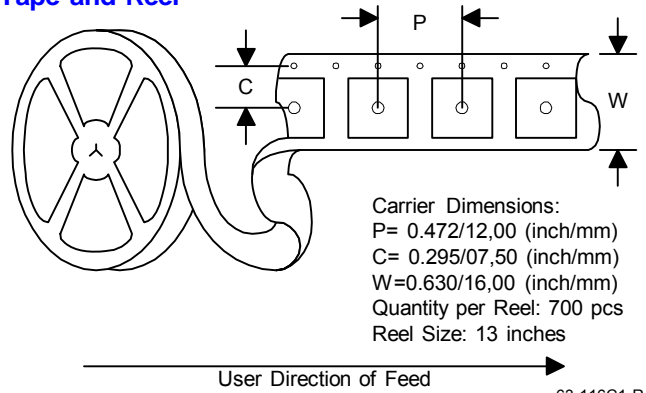

ENVIRONMENTAL & RELIABILITY DATA

Storage Temperature: -40C to +125C
Operating Temperature: -40C to +125C
Resistance to Solder Reflow: 3 passes thru. +235C for 30 seconds minimum

Marking permanency: Tested per JESD22-B107-A
Solderability: Tested per MIL-STD-750D
Life Test: Tested per MIL-STD-202F, Method 108A
Thermal Cycle: Tested per JESD22-B104-B, Test Condition G

ABOUT US

Vitec Electronics Corporation, founded in 1986, is a worldwide leader in the design, manufacture and sale of magnetic solutions. Vitec's market focus includes the power, power conditioning, telecom, networking, communications and computing. Vitec has also established strong alliances with chip manufacturers whereby magnetic solutions are designed in conjunction with unique silicon requirements and are offered as reference designs by the chip companies.

With its Corporate Headquarters and Research & Development center located in Carlsbad, California, and its state of the art manufacturing facility and material sourcing in China, Vitec is uniquely positioned to supply the latest technology at the lowest cost. Vitec offers both standard and custom product design capabilities with all of its facilities being ISO certified.

QUALITY POLICY

Vitec will provide products and services that meet or exceed our Customer's requirements, conform to company policies and standards, and exhibit continuously improving levels of Quality.

COMMITMENT

VITEC Electronics empowers each of its employees by providing a business environment that encourages a commitment to excellence, a sense of ownership and personal accountability to all Vitec Customers.

Competitive Pricing, Quality Products, and On Time Deliveries are expected from today's World Class Magnetics Suppliers. The high standards of today's customer are strengthening the dedication and commitment of VITEC Electronics to provide Total Customer Service.

CONTACT US

USA

VITEC ELECTRONICS CORPORATION
6213 El Camino Real
Carlsbad, CA 92009
U.S.A.

TEL: +1 (760) 918-8831
FAX: +1 (760) 918-8840

ASIA

SHANGHAI VITEC ELECTRONICS CO., LTD.
3369 He Chuan Road
Min Hang District, Shanghai, 201103
China

TEL: +86 (21) 6446-4828
FAX: +86 (21) 6446-4865

High Frequency Power Inductor

59P53-XXX

FEATURES

- Designed for use in VRM 9.X, 10.X & 11.X Applications.
- Operating Frequency 0.100 - 2.0 MHz.
- Operating Temperature Range of -40°C to 125°C.
- RoHS Compliant Version Available.
- Surface Mount Package for pick and place assembly.
- Low Profile SMT Package.

DRAWING

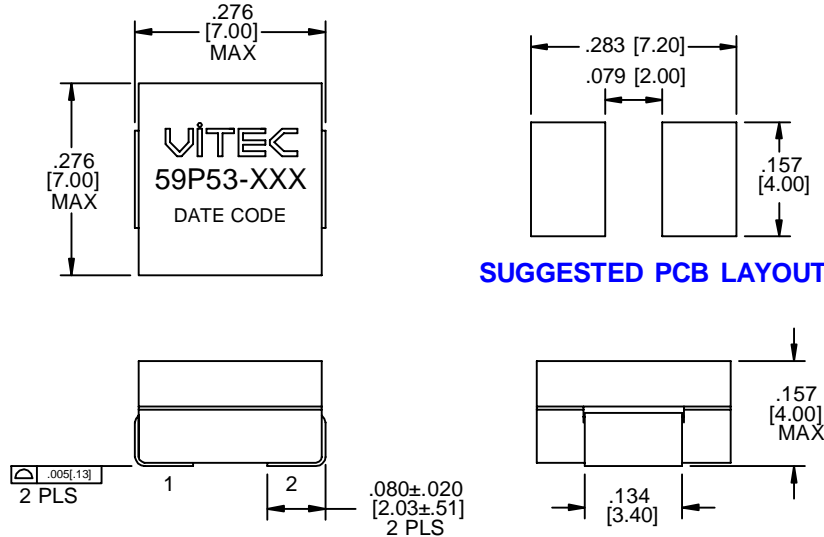

SCHEMATIC

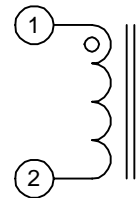

ALL DIMENSIONS GIVEN IN INCHES (MM).
TOLERANCES UNLESS OTHERWISE SPECIFIED.
XX±.01 [X±.25] .XX±.005 [XX±.13] ANGULAR: ±1°

ELECTRICAL CHARACTERISTICS @ 25°C

Part Number		Inductance @ 0Adc ⁴	Inductance @ Irated ⁴	Irated ¹	DCR	MAX Saturation Current ²			Temp. Rise Current ³	Temp. Rise Factor ⁵
Classic	RoHS	nH	nH	ADC	mOhms	ADC	ADC	ADC	ADC	
		-	MIN	MAX	±10%	-40°C	25°C	125°C	MAX	
59P53-750	59PR53-750	75 ±10%	54	42	0.40	43	42	33	30	0.03627
59P53-101	59PR53-101	100 ±10%	72	32	0.40	33	32	24	30	0.04841
59P53-151	59PR53-151	150 ±10%	108	21	0.40	22	21	16	30	0.07271
59P53-201	59PR53-201	200 ±10%	144	15	0.40	15.5	15	12	30	0.09698
59P53-471	59PR53-471	470 ±15%	320	5	0.40	5.5	5	3.6	30	0.22798

Notes:

- 1 - The rated current is the saturation current @ 25°C.
- 2 - The I(Saturation) is the current at which the inductance drops by 20% maximum of its value at 0ADC. This current is measured at the stated ambient environment and by applying a short duration pulse current to the component, minimizing the self-heating effects.
- 3 - The I(Temp. Rise) is the current at which the temperature of the part increases by a maximum of 50°C. This test is performed with the part mounted on a PCB with traces having 1.7 times the cross sectional area of the copper leads and applying the DC current for a minimum of 30 minutes.
- 4 - Inductance is measured at 100 KHz and 1.0 Vrms.
- 5 - Temperature Rise can be estimated using the following formulas:

PRELIMINARY

$$\text{Trise } (^\circ\text{C}) = \left(\frac{\text{Core Loss} + \text{DCR Loss}}{3.29} \right)^{0.833}$$

$$\text{DCR Loss (mW)} = \left(\text{IDC}^2 + \left(\frac{\Delta I}{2} \right)^2 \right) \times \text{DCR (mOhms)}$$

$$\text{Core Loss (mW)} = 0.001655 \times (F)^{1.84} \times (\text{Temp. Rise Factor} \times \Delta)^{2.28}$$

IDC = DC Output Current (ADC)

ΔI = Delta I across the inductor (Amps)

F = Switching Frequency (kHz)

This drawing is the property of Vitec Electronics Corporation. It is not a controlled document. Therefore it is subject to change without prior notice. Its intended use is to supply preliminary information only. Duplication of all or any part of this drawing is prohibited.

This page intentionally left blank

SMD High Frequency Power Inductor

Designed for VRM 9.x, 10.x, & 11.x Applications

FEATURES

- Recommended for use with all major Voltage Regulator ICs.
- High Current handling capability in the smallest footprint.
- Up to 2MHz operating frequency.
- Extended operating temperature range: -40C to 125C.
- Robust SMD package capable of handling the most aggressive SMT assembly process.
- RoHS compliant version available.

APPLICATIONS

- VRM 9.x, 10.x, and 11.x based designs
- Multi-Phase Voltage regulator designs
- Server, Desktop, PDA, Graphics cards, Notebook computers, DDR, telecom switches and routers
- DC-DC converters, Battery powered devices, high current power supplies
- High Current NPUs in networking equipment
- Point-of-load Modules
- DCR sensing

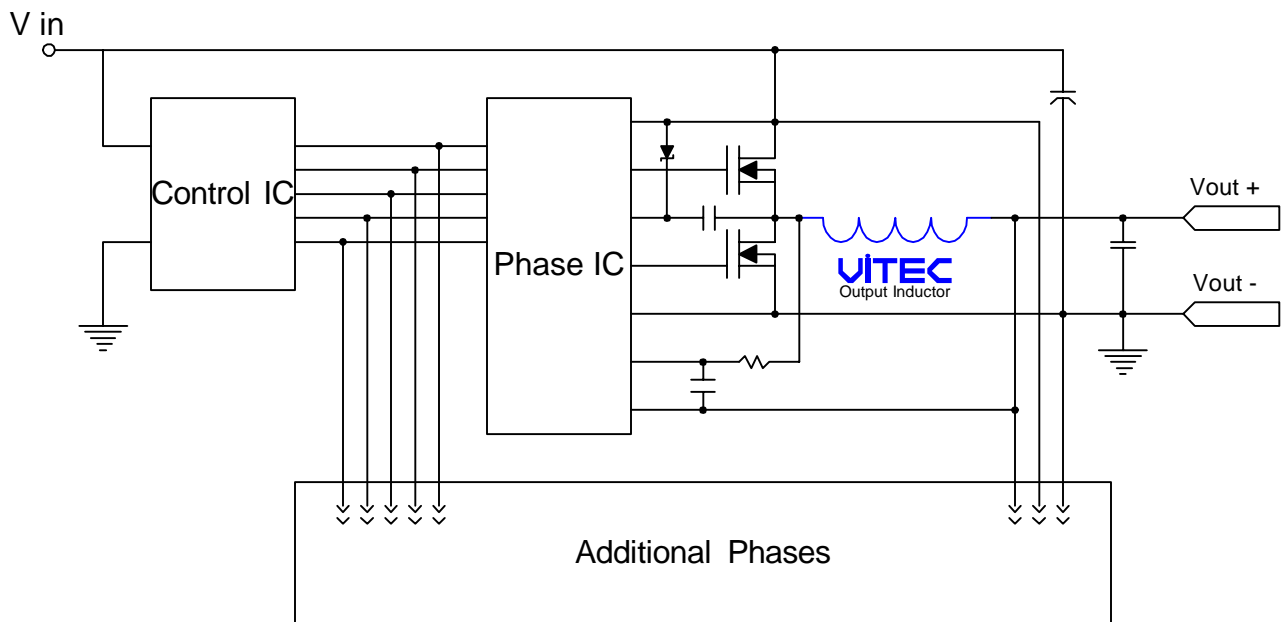

Typical Multi-Phase Application Circuit for a Buck Converter

SMD High Frequency Power Inductor

Designed for VRM 9.x, 10.x, & 11.x Applications

PACKAGE

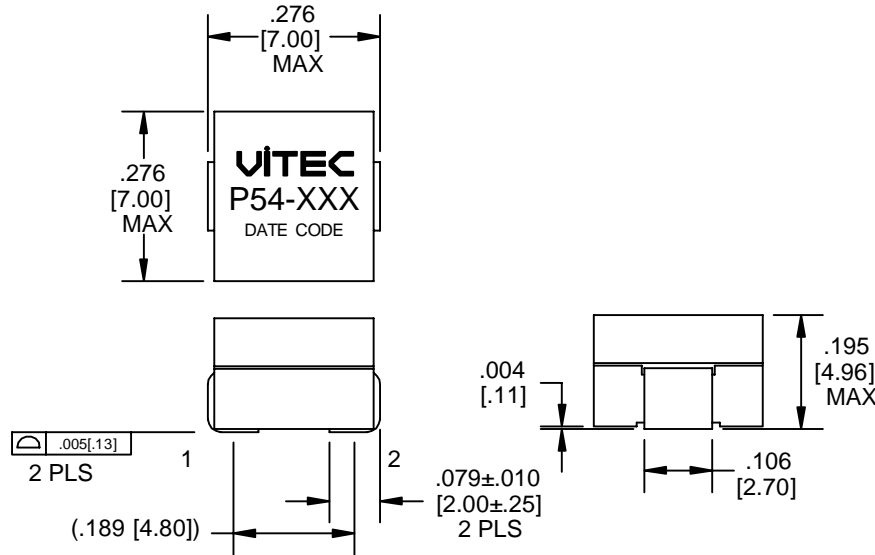

Dimensions: Inches [mm]. Tolerances: +/- 0.005" [0,13mm] unless otherwise noted

SCHEMATIC

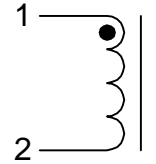

SUGGESTED PCB LAYOUT

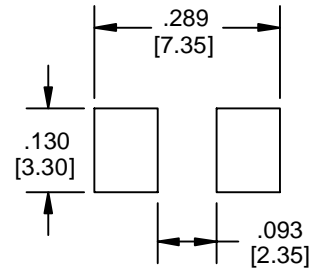

Drawing NOT to scale

ELECTRICAL CHARACTERISTICS @ 25°C (unless otherwise noted)

Part Number		Inductance @ 0 ADC (4)	Inductance @ Irated (4)(1)	Inductance @ Isat 25°C (4)(2)	Irated (1)	DCR	Isat Max Saturation Current (2)			Temp. Rise Current (3) ADC	Temp. Rise Factor A (5)	Temp. Rise Factor B (5)	Temp. Rise Factor C (5)
		nH	nH	nH	ADC		mOhm	ADC	ADC				
Classic	RoHS	± 10%	TYP	MIN	MAX	± 8%	25°C	100°C	125°C	MAX			
59P54-700	59PR54-700	70	67	50	40	0.27	64	57	52	40	3.65	0.001894	0.02910
59P54-101	59PR54-101	100	95	72	40	0.27	44	40	36	40	3.65	0.001873	0.04168
59P54-121	59PR54-121	120	96	86	37	0.27	37	33	30	40	3.65	0.001865	0.05006
59P54-151	59PR54-151	150	120	108	30	0.27	30	26	24	40	3.65	0.001860	0.06260
59P54-181	59PR54-181	180	144	130	25	0.27	25	22	20	40	3.65	0.001856	0.07514
59P54-221	59PR54-221	220	176	158	20	0.27	20	18	16	40	3.65	0.001853	0.09186

Add an "R" to the part number after "P" for the RoHS compliant version (i.e. 59PR54-101 is the RoHS compliant version of 59P54-101).

- The Rated Current (Irated) is either the Saturation Current at 25oC or the Temperature Rise Current ; the lowest number of the two specified currents.
- The Saturation Current (Isat) is the current at which the Inductance drops by a maximum of 20% below the lower limit of its value specified at 0 ADC Bias. Inductance at Isat is measured at the specified Ambient Temperature by applying DC Bias by a short period of time to minimize the self-heating effect of the component.
- The Temperature Rise Current is the current at which the temperature of the part increases by 50oC. This test is performed with the part mounted on a PCB with traces having 1.7 times the cross sectional area of the copper leads of the part. The temperature of the part is measured after applying the DC current for a minimum of 10 minutes.
- Inductance is measured at 100 KHz and 1.0 Vrms.
- Temperature Rise can be estimated using the following formulas:

$$T_{rise} (°C) = \left(\frac{\text{Core Loss} + \text{DCR Loss}}{\text{TRF A}} \right)^{0.833}$$

$$\text{DCR Loss (mW)} = \left(I_{dc}^2 + \left(\frac{\Delta I}{2} \right)^2 \right) \times \text{TYP DCR (mOhms)}$$

$$\text{Core Loss (mW)} = \text{TRF B} \times (F)^{1.84} \times (\text{TRF C} \times \Delta I)^{2.28}$$

IDC = DC output current (ADC)

Δ I = Delta I across the inductor (Amps)

F = Switching frequency (kHz)

SMD High Frequency Power Inductor

Designed for VRM 9.x, 10.x, & 11.x Applications

59PR54-700 Inductance vs. I_{dc} @ 25°C

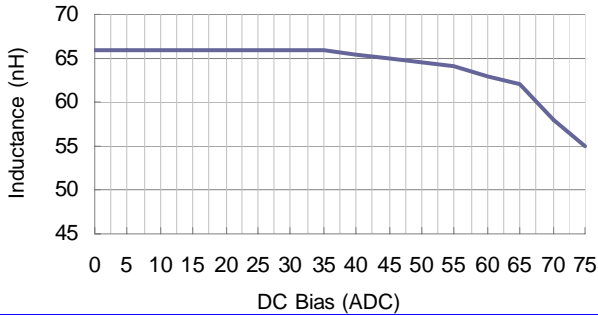

59PR54-101 Inductance vs. I_{dc} @ 25°C

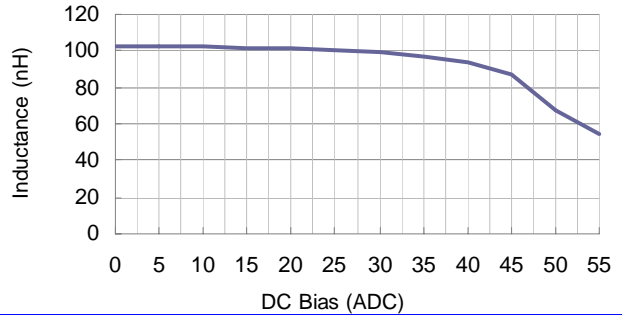

59PR54-121 Inductance vs. I_{dc} @ 25°C

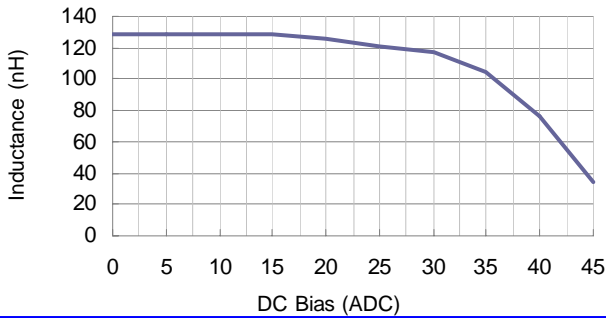

59PR54-151 Inductance vs. I_{dc} @ 25°C

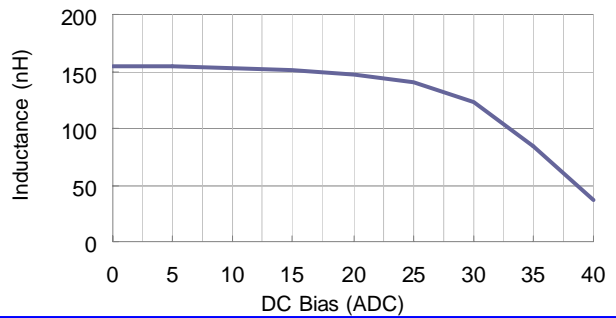

59PR54-181 Inductance vs. I_{dc} @ 25°C

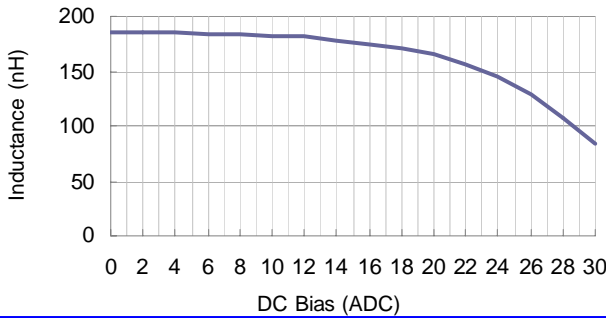

59PR54-221 Inductance vs. I_{dc} @ 25°C

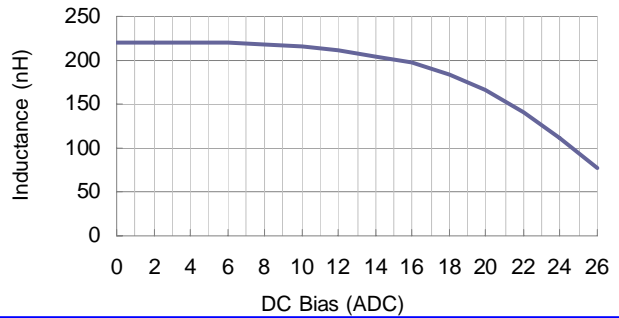

59PR54-XXX Temp. Rise vs. I_{dc}

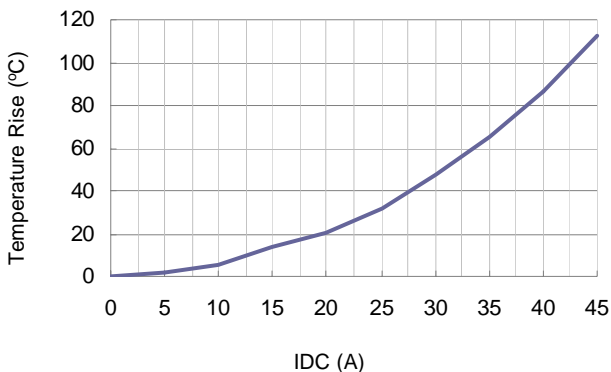

SMD High Frequency Power Inductor

Designed for VRM 9.x, 10.x, & 11.x Applications

IR Profile

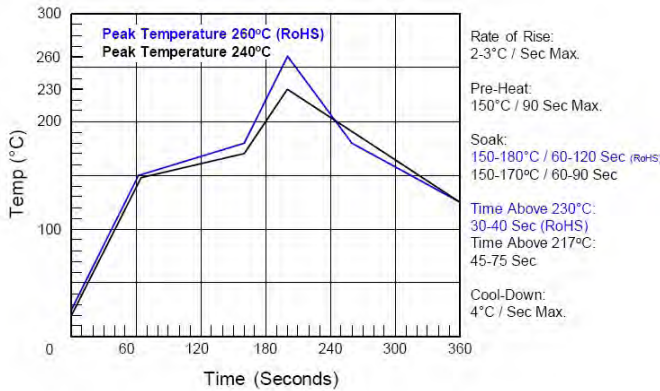

Tape and Reel

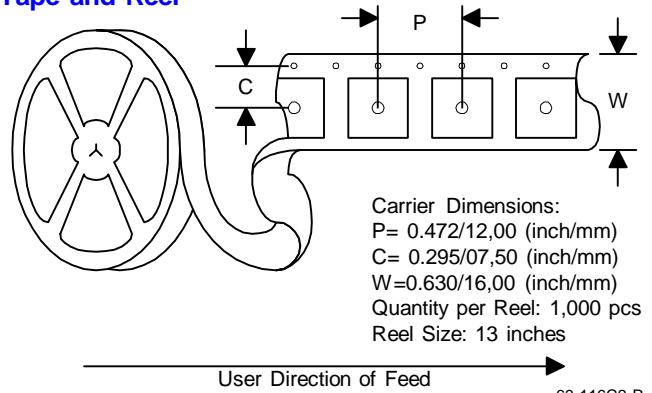

ENVIRONMENTAL & RELIABILITY DATA

Storage Temperature: -40C to +125C
Operating Temperature: -40C to +125C
Resistance to Solder Reflow: 3 passes thru. +235C for 30 seconds minimum

Marking permanency: Tested per JESD22-B107-A
Solderability: Tested per MIL-STD-750D
Life Test: Tested per MIL-STD-202F, Method 108A
Thermal Cycle: Tested per JESD22-B104-B, Test Condition G

ABOUT US

Vitec Electronics Corporation, founded in 1986, is a worldwide leader in the design, manufacture and sale of magnetic solutions. Vitec's market focus includes the power, power conditioning, telecom, networking, communications and computing. Vitec has also established strong alliances with chip manufacturers whereby magnetic solutions are designed in conjunction with unique silicon requirements and are offered as reference designs by the chip companies.

With its Corporate Headquarters and Research & Development center located in Carlsbad, California, and its state of the art manufacturing facility and material sourcing in China, Vitec is uniquely positioned to supply the latest technology at the lowest cost. Vitec offers both standard and custom product design capabilities with all of its facilities being ISO certified.

QUALITY POLICY

Vitec will provide products and services that meet or exceed our Customer's requirements, conform to company policies and standards, and exhibit continuously improving levels of Quality.

COMMITMENT

VITEC Electronics empowers each of its employees by providing a business environment that encourages a commitment to excellence, a sense of ownership and personal accountability to all Vitec Customers.

Competitive Pricing, Quality Products, and On Time Deliveries are expected from today's World Class Magnetics Suppliers. The high standards of today's customer are strengthening the dedication and commitment of VITEC Electronics to provide Total Customer Service.

CONTACT US

USA

VITEC ELECTRONICS CORPORATION
6213 El Camino Real
Carlsbad, CA 92009
U.S.A.

TEL: +1 (760) 918-8831
FAX: +1 (760) 918-8840

ASIA

SHANGHAI VITEC ELECTRONICS CO., LTD.
3369 He Chuan Road
Min Hang District, Shanghai, 201103
China

TEL: +86 (21) 6446-4828
FAX: +86 (21) 6446-4865

SMD High Frequency Power Inductor

Designed for VRM 9.x, 10.x, & 11.x Applications

FEATURES

- Recommended for use with all major Voltage Regulator ICs
- High Current handling capability in the smallest footprint & profile
- Up to 2MHz operating frequency
- Extended operating temperature range: -40°C to 125°C
- Robust SMD package capable of handling the most aggressive SMT assembly process
- RoHS compliant version available



APPLICATIONS

- VRM 9.0, 10.x, and 11.x based designs
- Multi-Phase Voltage regulator designs
- Server, Desktop, PDA, Graphics cards, Notebook computers, DDR, telecom switches and routers
- DC-DC converters, Battery powered devices, high current power supplies
- High Current NPUs in networking equipment
- Point-of-load Modules

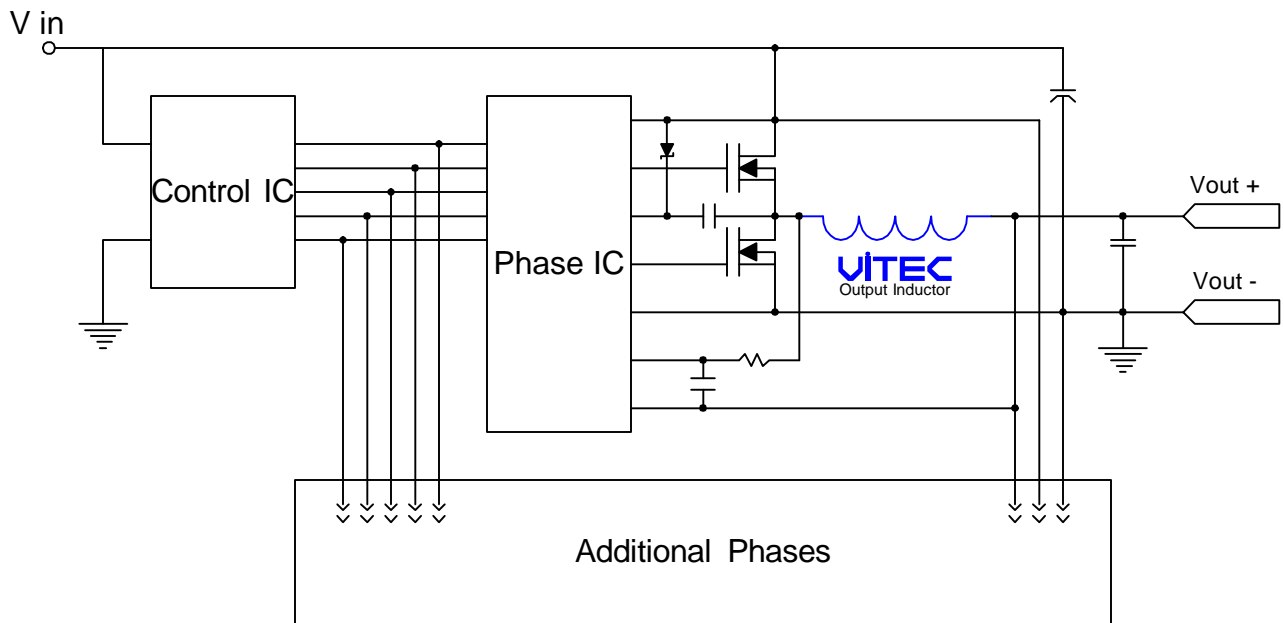

Typical Multi-Phase Application Circuit for a Buck Converter

PRELIMINARY

SMD High Frequency Power Inductor

Designed for VRM 9.x, 10.x, & 11.x Applications

PACKAGE

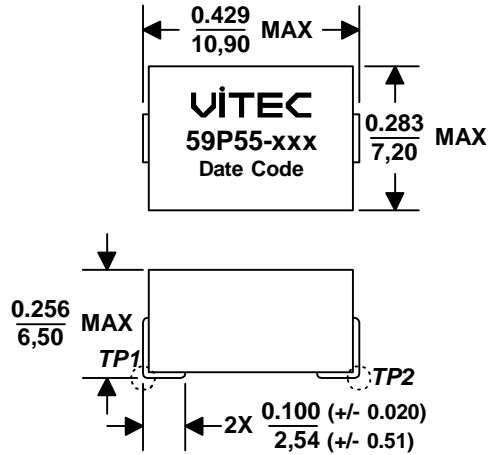

All dimensions given in inches [mm].
Tolerances unless otherwise specified. 0.XX±0.01 [0.X±0.25] 0.XXX±0.005 [0.XX±0.13] Angular ± 1°

SCHEMATIC

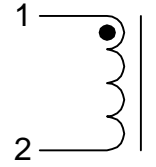

SUGGESTED PCB LAYOUT

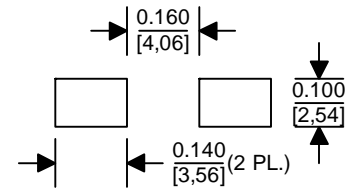

Drawing NOT to scale

ELECTRICAL CHARACTERISTICS @ 25°C (unless otherwise noted)

Part Number		Inductance @ 0Adc ⁴	Inductance ⁴ @ Isat ²	DCR ⁵	Isat ² Max Saturation Current			Temp. Rise Current ³		Temp. Rise Factor ⁶ (TRF)		
Classic	RoHS	nH ± 10%	nH MIN	mOhm ± 8%	ADC			ADC MAX		A	B	C
					25°C	100°C	125°C	50°C	60°C			
59P55-121	59PR55-121	120	86	0.48	75	65	61	38	40	6.33	0.003695	0.02469
59P55-171	59PR55-171	170	122	0.48	52	45	43	38	40	6.33	0.003655	0.03505
59P55-221	59PR55-221	220	158	0.48	40	35	33	38	40	6.33	0.003630	0.04542
59P55-301	59PR55-301	300	216	0.48	29	26	24	38	40	6.33	0.003616	0.06197
59P55-471	59PR55-471	470	338	0.48	17	16	15	38	40	6.33	0.003600	0.09713

Add an "R" to the part number after "P" for the RoHS compliant version (i.e. 59PR55-121 is the RoHS compliant version of 59P55-121).

- The Rated Current (I_{rated}) is either the Saturation Current at 25°C or the Temperature Rise Current; the lowest number of the two specified currents.
- The Saturation Current (I_{sat}) is the current at which the Inductance drops by a maximum of 20% below the lower limit of its value specified at 0 ADC Bias. Inductance at I_{sat} is measured at the specified Ambient Temperature by applying DC Bias by a short period of time to minimize the self-heating effect of the component.
- The Temperature Rise Current is the current at which the temperature of the part increases by 50°C. This test is performed with the part mounted on a PCB with traces having 1.75 times the cross sectional area of the copper leads of the part. The temperature of the part is measured after applying the DC current for a minimum of 10 minutes.
- Inductance is measured at 100 KHz and 1.0 Vrms.
- The normal DCR tolerance is by design, DCR is measured from lead to lead at test point TP1 - TP2.
- Temperature Rise can be estimated using the following formulas:

$$\text{Trise (}^\circ\text{C)} = \left(\frac{\text{Core Loss} + \text{DCR Loss}}{\text{TRF A}} \right)^{0.833}$$

$$\text{DCR Loss (mW)} = \left(I_{dc}^2 + \left(\frac{\Delta I}{2} \right)^2 \right) \times \text{TYP DCR (mOhms)}$$

$$\text{Core Loss (mW)} = \text{TRF B} \times (F)^{1.84} \times (\text{TRF C} \times \Delta I)^{2.28}$$

IDC = DC output current (ADC)

ΔI = Delta I across the inductor (Amps)

F = Switching frequency (kHz)

PRELIMINARY

SMD High Frequency Power Inductor

Designed for VRM 9.x, 10.x, & 11.x Applications

PRELIMINARY

59P55-121 Inductance vs DC Bias @ 25°C

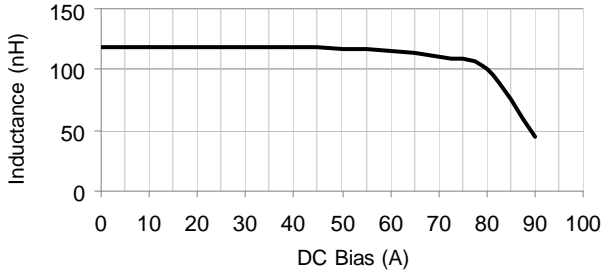

59P55-171 Inductance vs DC Bias @ 25°C

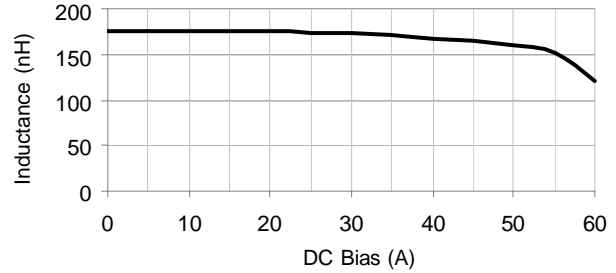

59P55-221 Inductance vs DC Bias @ 25°C

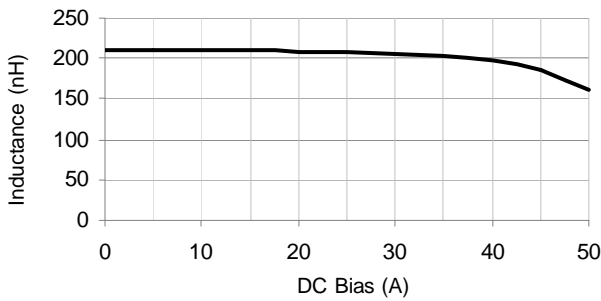

59P55-301 Inductance vs DC Bias @ 25°C

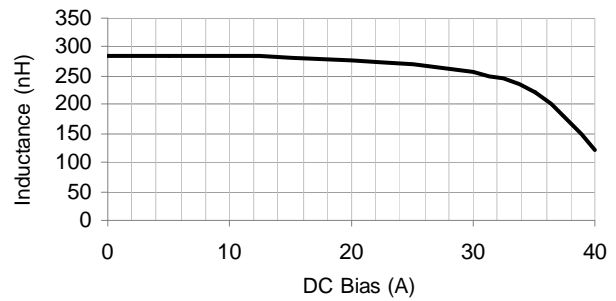

59P55-471 Inductance vs DC Bias @ 25°C

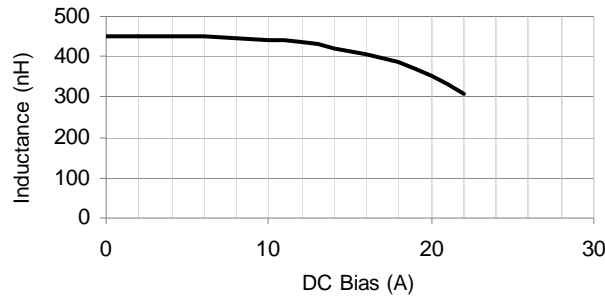

59P55-xxx Temp. Rise vs. IDC

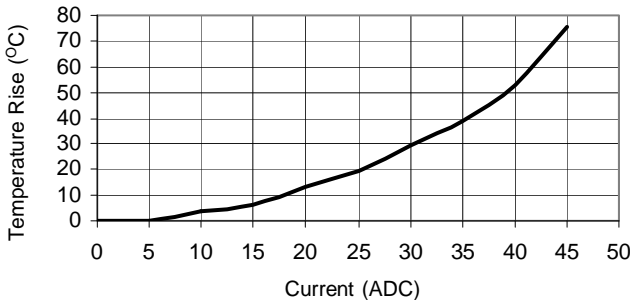

59P55-xxx RDC vs. Temperature

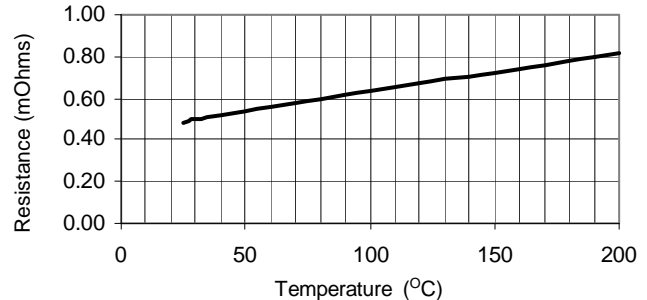

ENVIRONMENTAL & RELIABILITY DATA

Storage Temperature: -40C to +125C
 Operating Temperature: -40C to +125C
 Resistance to Solder Reflow: 3 passes thru. +235C for 30 seconds minimum

Marking permanency: Tested per JESD22-B107-A
 Solderability: Tested per JESD22-B102D
 Life Test: Tested per MIL-STD-202F, Method 108A
 Thermal Cycle: Tested per JESD22-B104-B, Test Condition G

SMD High Frequency Power Inductor

Designed for VRM 9.x, 10.x, & 11.x Applications

IR Profile

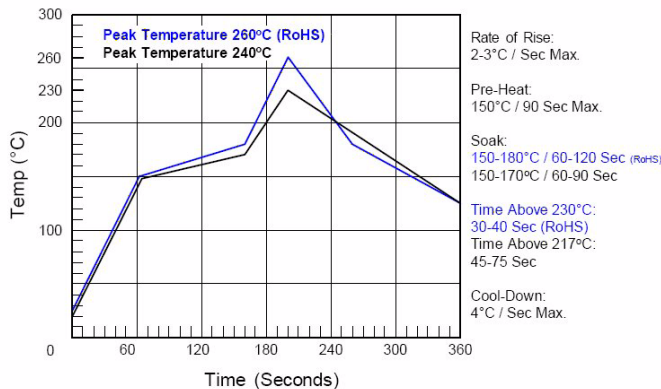

Tape and Reel

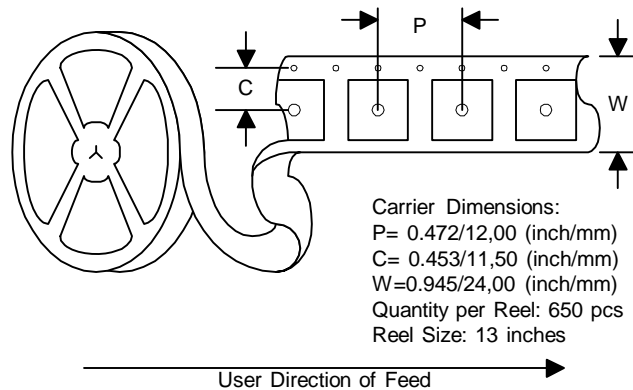

63-224A1

ABOUT US

Vitec Electronics Corporation, founded in 1986, is a worldwide leader in the design, manufacture and sale of magnetic solutions. Vitec's market focus includes the power, power conditioning, telecom, networking, communications and computing. Vitec has also established strong alliances with chip manufacturers whereby magnetic solutions are designed in conjunction with unique silicon requirements and are offered as reference designs by the chip companies.

With its Corporate Headquarters and Research & Development center located in Carlsbad, California, and its state of the art manufacturing facility and material sourcing in China, Vitec is uniquely positioned to supply the latest technology at the lowest cost. Vitec offers both standard and custom product design capabilities with all of its facilities being ISO certified.

QUALITY POLICY

Vitec will provide products and services that meet or exceed our Customer's requirements, conform to company policies and standards, and exhibit continuously improving levels of Quality.

COMMITMENT

VITEC Electronics empowers each of its employees by providing a business environment that encourages a commitment to excellence, a sense of ownership and personal accountability to all Vitec Customers.

Competitive Pricing, Quality Products, and On Time Deliveries are expected from today's World Class Magnetics Suppliers. The high standards of today's customer are strengthening the dedication and commitment of VITEC Electronics to provide Total Customer Service.

CONTACT US

USA

VITEC ELECTRONICS CORPORATION
6213 El Camino Real
Carlsbad, CA 92009
U.S.A.

TEL: +1 (760) 918-8831
FAX: +1 (760) 918-8840

ASIA

SHANGHAI VITEC ELECTRONICS CO., LTD.
3369 He Chuan Road
Min Hang District, Shanghai, 201103
China

TEL: +86 (21) 6446-4828
FAX: +86 (21) 6446-4865

SMD High Frequency Power Inductor

Designed for VRD & VRM 10.X & 11.X Applications

FEATURES

- Low Profile SMT Package
- Operating Frequency of 0.100 - 2.0 MHz
- Extended Operating Temperature Range of -40°C to 125°C
- High Current Handling Capability in the Smallest Footprint

MECHANICAL

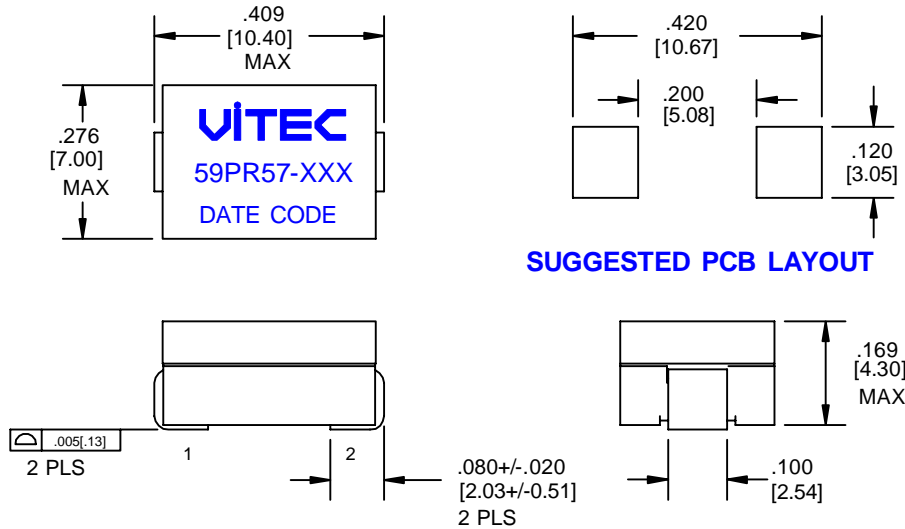

ALL DIMENSIONS GIVEN IN INCHES [MM].
TOLERANCES UNLESS OTHERWISE SPECIFIED.
.XX +/- .01 [X +/- 0.25] .XXX +/- .005 [XX +/- 0.13] ANGULAR: +/- 1°

SCHEMATIC

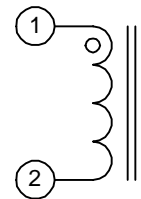

ELECTRICAL CHARACTERISTICS @ 25°C

Part Number		Inductance @ 0ADC ⁴	Inductance @ I _{rated} ⁴	I _{rated} ¹	DCR	MAX Saturation Current ²			Temp. Rise Current ³	Temp. Rise Factor ⁵
Classic	RoHS	nH	nH	ADC	mOhms	ADC	ADC	ADC	ADC	
		+/-10%	MIN	MAX	+/-10%	-40°C	25°C	125°C	MAX	
59P57-121	59PR57-121	120	86	25	0.45	26	25	20	25	0.036520
59P57-201	59PR57-201	200	144	20	0.45	21	20	16	25	0.060867

Add an "R" to the part number after "P" for the RoHS compliant version

Notes:

1. The rated current is the saturation current @ 25°C.
2. The I(Saturation) is the current at which the inductance drops by 20% maximum of its value at 0ADC. This current is measured at the stated ambient environment and by applying a short duration pulse current to the component, minimizing the self-heating effects.
3. The I(Temp. Rise) is the current at which the temperature of the part increases by a maximum of 50°C. This test is performed with the part mounted on a PCB with traces having 1.7 times the cross sectional area of the copper leads and applying the DC current for a minimum of 30 minutes.
4. Inductance is measured at 100 KHz and 1.0 Vrms.
5. Temperature Rise can be estimated using the following formulas:

$$\text{Trise (}^\circ\text{C)} = \left(\frac{\text{Core Loss} + \text{DCR Loss}}{2.48} \right)^{0.833}$$

$$\text{DCR Loss (mW)} = \left(\text{IDC}^2 + \left(\frac{\Delta I}{2} \right)^2 \right) \times \text{TYP DCR (mOhms)}$$

$$\text{Core Loss (mW)} = 0.002292 \times (F)^{1.84} \times (\text{Temp. Rise Factor} \times \Delta I)^{2.28}$$

IDC = DC Output Current (ADC)

ΔI = Delta I across the inductor (Amps)

F = Switching Frequency (kHz)

This drawing is the property of Vitec Electronics Corporation. It is not a controlled document. Therefore it is subject to change without prior notice. Its intended use is to supply preliminary information only. Duplication of all or any part of this drawing is prohibited.

This page intentionally left blank

High Frequency Power Inductor

59P58-XXX

FEATURES

- Designed for use in VRM 9.X, 10.X & 11.X Applications.
- Operating Frequency 0.100 - 2.0 MHz.
- Operating Temperature Range of -40°C to 125°C.
- RoHS Compliant Version Available.
- Surface Mount Package for pick and place assembly.

DRAWING

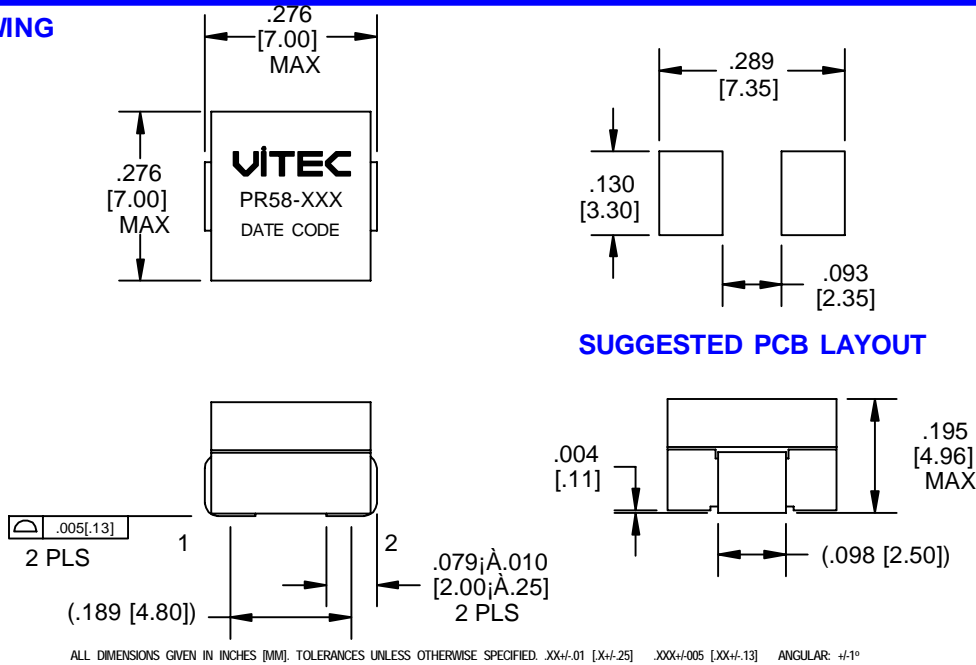

SCHEMATIC

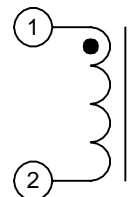

ALL DIMENSIONS GIVEN IN INCHES [MM]. TOLERANCES UNLESS OTHERWISE SPECIFIED. .XX±.01 [X±.25] .XXX±.005 [XX±.13] ANGULAR: #1°

ELECTRICAL CHARACTERISTICS @ 25°C

Part Number		Inductance ⁴ @ 0 Adc	Inductance ⁴ @ Irated ¹	Inductance ⁴ @ Isat ²	Irated ¹	DCR	Isat ² Max Saturation Current			Temp. Rise Current ³	Temp. Rise Factor A (TRF A) ⁵	Temp. Rise Factor B (TRF B) ⁵	Temp. Rise Factor C (TRF C) ⁵
Classic	RoHS	nH +/-10%	nH TYP	nH MIN	ADC MAX	mOhms +/-10%	ADC 25°C	ADC 100°C	ADC 125°C	ADC MAX			
59P58-700	59PR58-700	70	67	50	40	0.42	64	57	52	32	3.65	0.001894	0.02910
59P58-101	59PR58-101	100	95	72	40	0.42	44	40	36	32	3.65	0.001873	0.04168
59P58-121	59PR58-121	120	96	86	37	0.42	37	33	30	32	3.65	0.001865	0.05006
59P58-151	59PR58-151	150	120	108	30	0.42	30	26	24	32	3.65	0.001860	0.06260
59P58-181	59PR58-181	180	144	130	25	0.42	25	22	20	32	3.65	0.001856	0.07514
59P58-221	59PR58-221	220	176	158	20	0.42	20	18	16	32	3.65	0.001853	0.09186

Add an "R" to the part number after "P" for the RoHS compliant version (i.e. 59PR58-700 is the RoHS compliant version of 59P58-700).

Notes:

- 1 - The Rated Current (Irated) is either the Saturation Current at 25°C or the Temperature Rise Current; the lowest number of the two specified currents.
- 2 - The Saturation Current (Isat) is the current at which the Inductance drops by a maximum of 20% below the lower limit of its value specified at 0 ADC Bias. Inductance at Isat is measured at the specified Ambient Temperature by applying DC Bias by a short period of time to minimize the self-heating effect of the component.
- 3 - The Temperature Rise Current is the current at which the temperature of the part increases by 50°C. This test is performed with the part mounted on a PCB with traces having 1.7 times the cross sectional area of the copper leads of the part. The temperature of the part is measured after applying the DC current for a minimum of 10 minutes.
- 4 - Inductance is measured at 100 KHz and 1.0 Vrms.
- 5 - Temperature Rise can be estimated using the following formulas:

$$Trise (^{\circ}C) = \left(\frac{\text{Core Loss} + \text{DCR Loss}}{\text{TRF A}} \right)^{0.833}$$

$$\text{DCR Loss (mW)} = \left(\text{IDC2} + \left(\frac{\Delta I}{2} \right)^2 \right) \times \text{TYP DCR (mOhms)}$$

$$\text{Core Loss (mW)} = \text{TRF B} \times (F)^{1.84} \times (\text{TRF C} \times \Delta I)^{2.28}$$

IDC = DC Output Current (ADC)

ΔI = Delta I across the inductor (Amps)

F = Switching Frequency (kHz)

This drawing is the property of Vitec Electronics Corporation. It is not a controlled document. Therefore it is subject to change without prior notice. It's intended use is to supply preliminary information only. Duplication of all or any part of this drawing is prohibited.

This page intentionally left blank

SMD High Frequency Power Inductor

Designed for VRM 9.x, 10.x, & 11.x Applications

FEATURES

- Recommended for use with all major Voltage Regulator ICs.
- High Current handling capability in the smallest footprint.
- Up to 2MHz operating frequency.
- Extended operating temperature range: -40°C to 125°C.
- Robust SMD package capable of handling the most aggressive SMT assembly process.
- RoHS compliant version available.

APPLICATIONS

- VRM 9.x, 10.x, and 11.x based designs
- Multi-Phase Voltage regulator designs
- Server, Desktop, PDA, Graphics cards, Notebook computers, DDR, telecom switches and routers
- DC-DC converters, Battery powered devices, high current power supplies
- High Current NPUs in networking equipment
- Point-of-load Modules
- DCR sensing

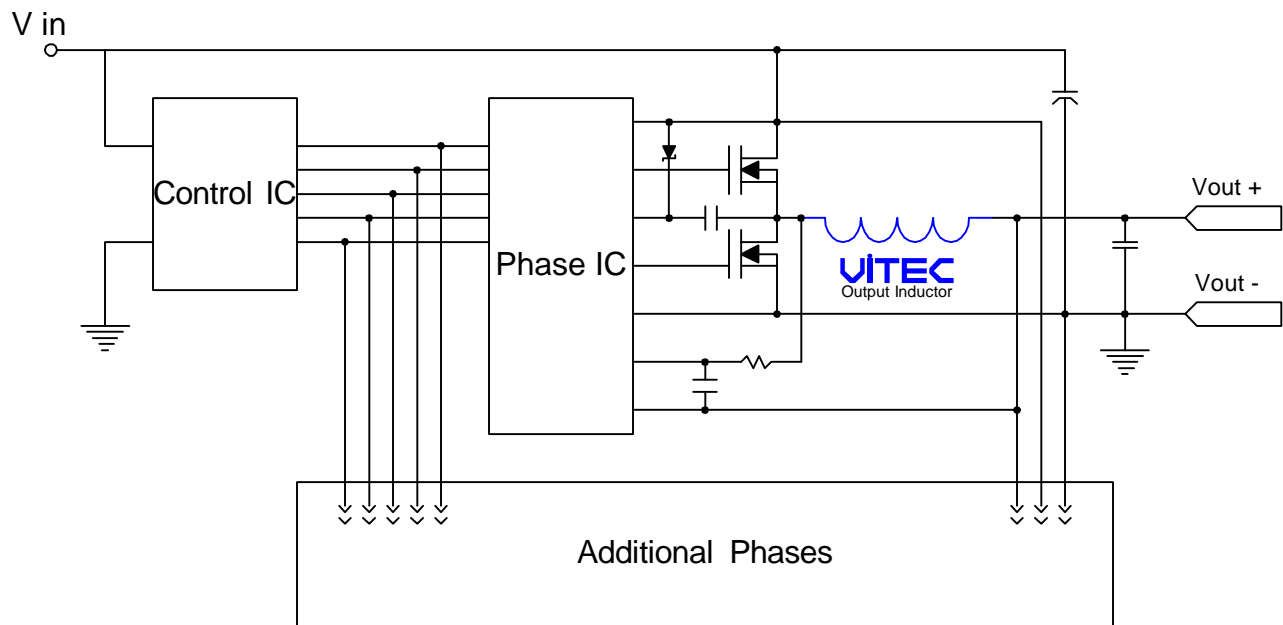

Typical Multi-Phase Application Circuit for a Buck Converter

SMD High Frequency Power Inductor

Designed for VRM 9.x, 10.x, & 11.x Applications

PACKAGE

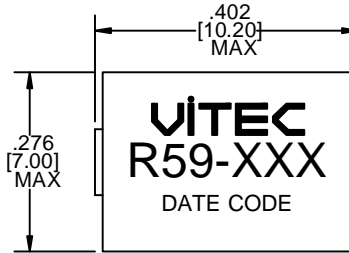

Note: Due to the mechanical dimension of the product, the prefix (59P) is omitted from the marking. 59P59-xxx series will be marked 59-xxx and 59PR59-xxx series will be marked R59-xxx.

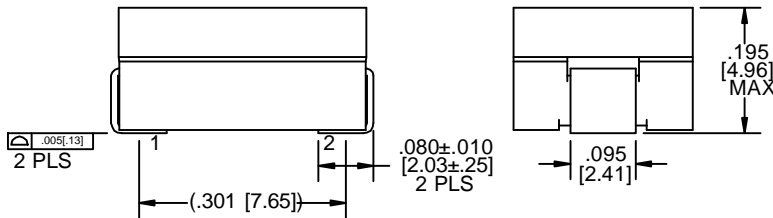

Dimensions: Inches [mm]. Tolerances: 0.XX" +/- 0.01 [0.25] 0.XXX" +/- 0.005" [0.13mm] unless otherwise noted

SCHEMATIC

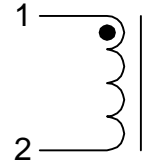

SUGGESTED PCB LAYOUT

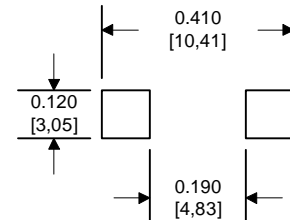

Drawing NOT to scale

ELECTRICAL CHARACTERISTICS @ 25°C (unless otherwise noted)

Part Number		Inductance @ 0 ADC (4)	Inductance @ Isat 25°C (4)(2)	DCR	Isat Max Saturation Current (2)			Temp. Rise Current (3)	Temp. Rise Factor A (5)	Temp. Rise Factor B (5)	Temp. Rise Factor C (5)
					ADC	ADC	ADC				
Classic	RoHS	nH ± 15%	nH MIN	mOhm ± 7.7%	ADC 25°C	ADC 100°C	ADC 125°C	ADC MAX			
59P59-850	59PR59-850	85	58	0.39	70	65	60	33	3.88	0.002671	0.02484
59P59-101	59PR59-101	100	68	0.39	61	55	52	33	3.88	0.002650	0.02928
59P59-121	59PR59-121	120	82	0.39	50	46	43	33	3.88	0.002639	0.03517
59P59-151	59PR59-151	150	102	0.39	40	37	35	33	3.88	0.002626	0.04400
59P59-181	59PR59-181	180	122	0.39	33	30	28	33	3.88	0.002616	0.05284
59P59-221	59PR59-221	220	150	0.39	27	25	23	33	3.88	0.002606	0.06465

Add an "R" to the part number after "P" for the RoHS compliant version (i.e. 59PR59-101 is the RoHS compliant version of 59P59-101).

- The Rated Current (I_{rated}) is either the Saturation Current at 25°C or the Temperature Rise Current; the lowest number of the two specified currents.
- The Saturation Current (Isat) is the current at which the Inductance drops by a maximum of 20% below the lower limit of its value specified at 0 ADC Bias. Inductance at Isat is measured at the specified Ambient Temperature by applying DC Bias by a short period of time to minimize the self-heating effect of the component.
- The Temperature Rise Current is the current at which the temperature of the part increases by 50°C. This test is performed with the part mounted on a PCB with traces having 1.7 times the cross sectional area of the copper leads of the part. The temperature of the part is measured after applying the DC current for a minimum of 10 minutes.
- Inductance is measured at 100 KHz and 1.0 Vrms.
- Temperature Rise can be estimated using the following formulas:

$$T_{rise} (^{\circ}C) = \left(\frac{\text{Core Loss} + \text{DCR Loss}}{\text{TRF A}} \right)^{0.833}$$

$$\text{DCR Loss (mW)} = \left(I_{dc}^2 + \left(\frac{\Delta I}{2} \right)^2 \right) \times \text{TYP DCR (mOhms)}$$

$$\text{Core Loss (mW)} = \text{TRF B} \times (F)^{1.84} \times (\text{TRF C} \times \Delta I)^{2.28}$$

IDC = DC output current (ADC)
 Δ I = Delta I across the inductor (Amps)
 F = Switching frequency (kHz)

SMD High Frequency Power Inductor

Designed for VRM 9.x, 10.x, & 11.x Applications

59PR59-850 Inductance vs. I_{dc}

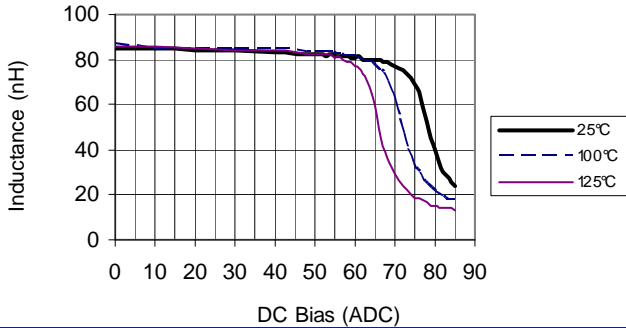

59PR59-101 Inductance vs. I_{dc}

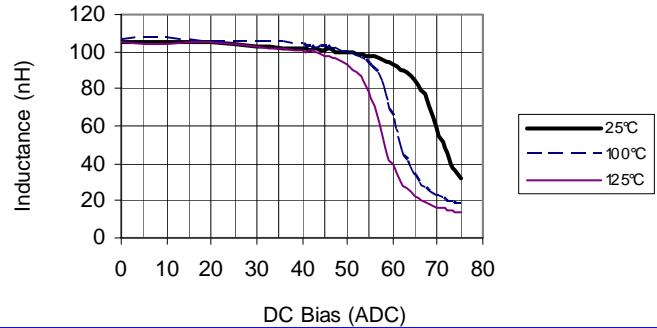

59PR59-121 Inductance vs. I_{dc}

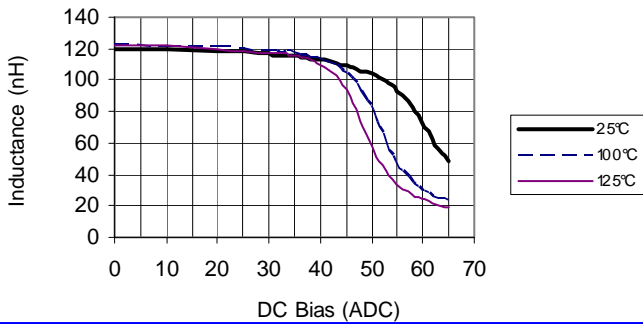

59PR59-151 Inductance vs. I_{dc}

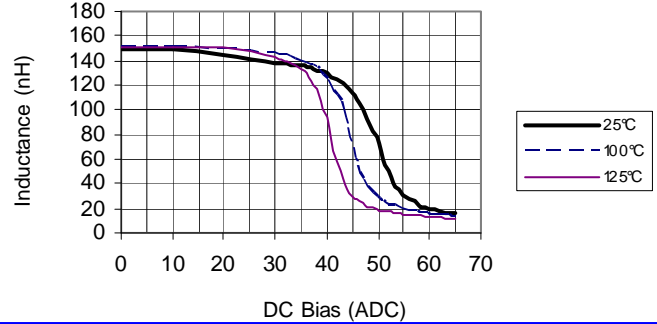

59PR59-181 Inductance vs. I_{dc}

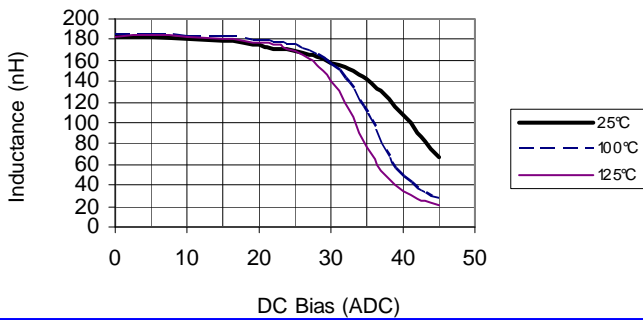

59PR59-221 Inductance vs. I_{dc}

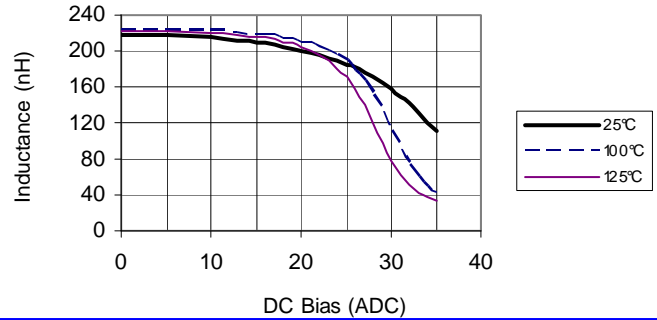

59PR59-XXX Temp. Rise vs. I_{dc}

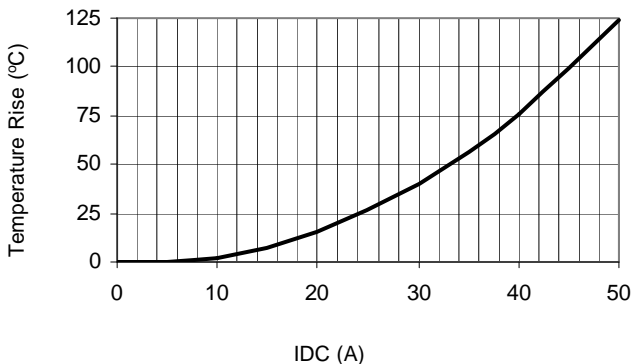

59PR59-XXX R_{dc} vs. Temperature

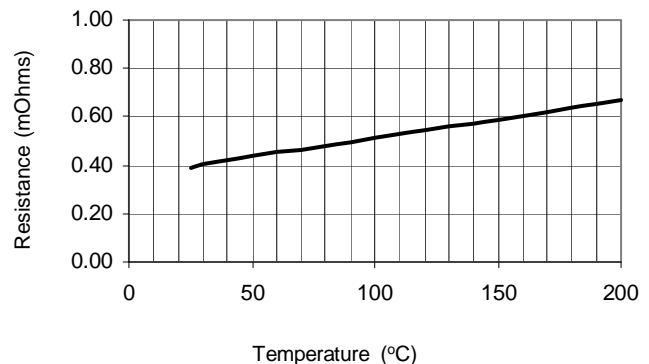

SMD High Frequency Power Inductor

Designed for VRM 9.x, 10.x, & 11.x Applications

IR Profile

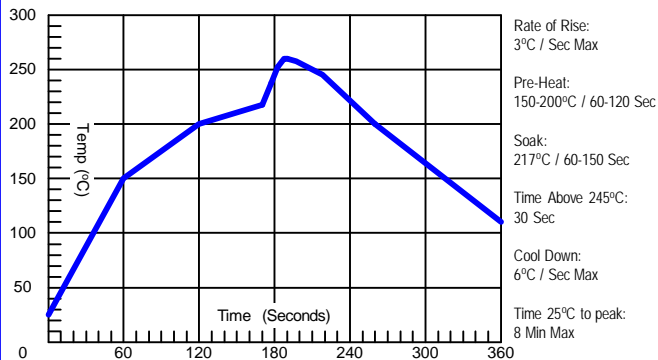

Tape and Reel

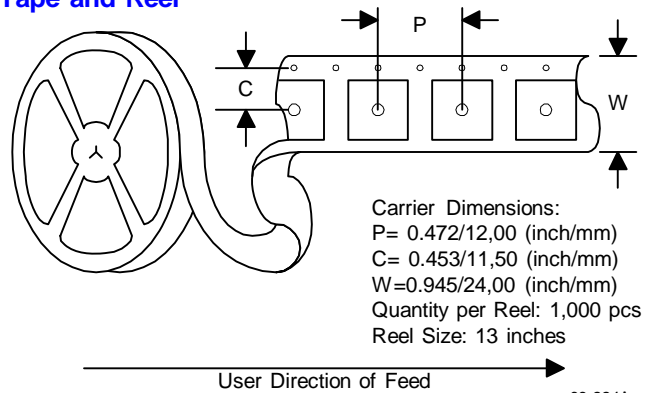

ENVIRONMENTAL & RELIABILITY DATA

Storage Temperature: -40°C to +125°C
Operating Temperature: -40°C to +125°C
Resistance to Solder Reflow: 3 passes thru. +245°C for 30 seconds minimum

Marking permanency: Tested per JESD22-B107-A
Solderability: Tested per MIL-STD-750D
Life Test: Tested per MIL-STD-202F, Method 108A
Thermal Cycle: Tested per JESD22-B104-B, Test Condition G

ABOUT US

Vitec Electronics Corporation, founded in 1986, is a worldwide leader in the design, manufacture and sale of magnetic solutions. Vitec's market focus includes the power, power conditioning, telecom, networking, communications and computing. Vitec has also established strong alliances with chip manufacturers whereby magnetic solutions are designed in conjunction with unique silicon requirements and are offered as reference designs by the chip companies.

With its Corporate Headquarters and Research & Development center located in Carlsbad, California, and its state of the art manufacturing facility and material sourcing in China, Vitec is uniquely positioned to supply the latest technology at the lowest cost. Vitec offers both standard and custom product design capabilities with all of its facilities being ISO certified.

QUALITY POLICY

Vitec will provide products and services that meet or exceed our Customer's requirements, conform to company policies and standards, and exhibit continuously improving levels of Quality.

COMMITMENT

VITEC Electronics empowers each of its employees by providing a business environment that encourages a commitment to excellence, a sense of ownership and personal accountability to all Vitec Customers.

Competitive Pricing, Quality Products, and On Time Deliveries are expected from today's World Class Magnetics Suppliers. The high standards of today's customer are strengthening the dedication and commitment of VITEC Electronics to provide Total Customer Service.

CONTACT US

USA

VITEC ELECTRONICS CORPORATION
6213 El Camino Real
Carlsbad, CA 92009
U.S.A.

TEL: +1 (760) 918-8831
FAX: +1 (760) 918-8840

ASIA

SHANGHAI VITEC ELECTRONICS CO., LTD.
3369 He Chuan Road
Min Hang District, Shanghai, 201103
China

TEL: +86 (21) 6446-4828
FAX: +86 (21) 6446-4865

SMD High Frequency Power Inductor

Designed for VRM 9.x, 10.x, & 11.x Applications

FEATURES

- Recommended for use with all major Voltage Regulator ICs.
- High Current handling capability in the smallest footprint.
- Up to 2MHz operating frequency.
- Extended operating temperature range: -40°C to 125°C.
- Robust SMD package capable of handling the most aggressive SMT assembly process.
- RoHS compliant version available.

APPLICATIONS

- VRM 9.x, 10.x, and 11.x based designs
- Multi-Phase Voltage regulator designs
- Server, Desktop, PDA, Graphics cards, Notebook computers, DDR, telecom switches and routers
- DC-DC converters, Battery powered devices, high current power supplies
- High Current NPUs in networking equipment
- Point-of-load Modules
- DCR sensing

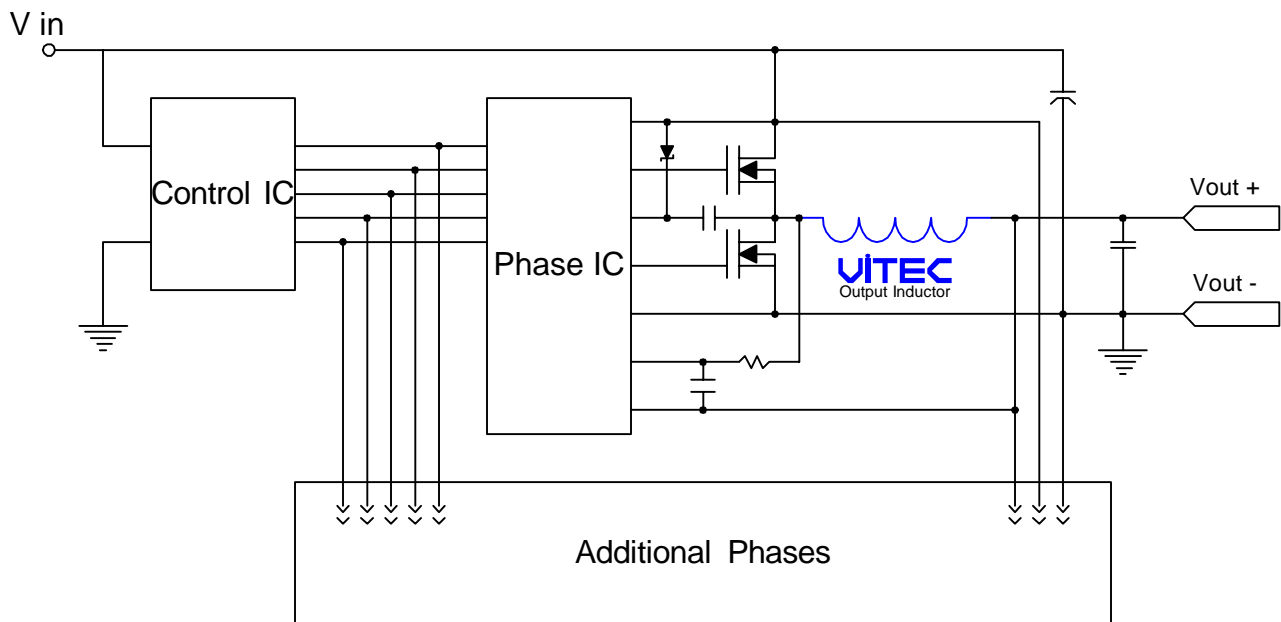

Typical Multi-Phase Application Circuit for a Buck Converter

SMD High Frequency Power Inductor

Designed for VRM 9.x, 10.x, & 11.x Applications

PACKAGE

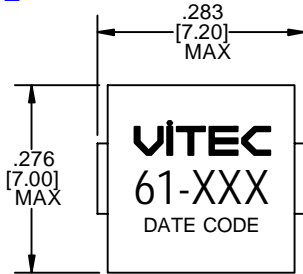

PART NUMBER	DIM A (MAX)
59P61-320	.201 [5.10]
59P61-580	.195 [4.96]
59P61-720	.195 [4.96]
59P61-101	.195 [4.96]
59P61-151	.195 [4.96]
59P61-201	.195 [4.96]

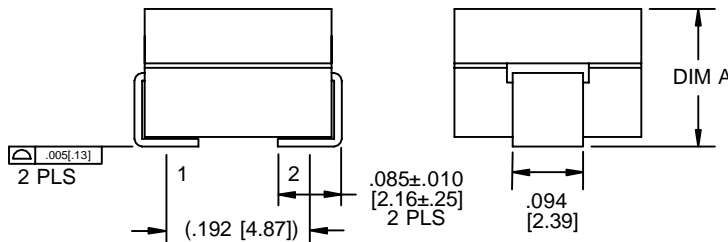

Dimensions: Inches [mm]. Tolerances: 0.XX" +/- 0.01 [0.25] 0.XXX" +/- 0.005" [0.13mm] unless otherwise noted

SCHEMATIC

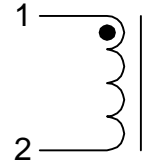

SUGGESTED PCB LAYOUT

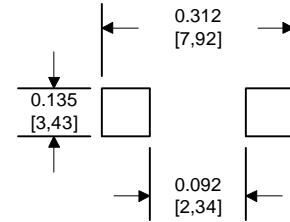

Drawing NOT to scale

ELECTRICAL CHARACTERISTICS @ 25°C (unless otherwise noted)

Part Number		Inductance @ 0 ADC (4)	Inductance @ Isat 25°C (4)(2)	DCR	Isat Max Saturation Current (2)			Temp. Rise Current (3)	Temp. Rise Factor A (5)	Temp. Rise Factor B (5)	Temp. Rise Factor C (5)
					ADC	ADC	ADC				
Classic	RoHS	nH	nH	mOhm	25°C	100°C	125°C	ADC			
59P61-320	59PR61-320	± 15%	MIN	± 6.5%	112	92	85	MAX	3.38	0.001938	0.01464
59P61-580	59PR61-580	32	22	0.32	76	63	59	34	3.38	0.001818	0.02363
59P61-720	59PR61-720	58	39	0.32	58	48	45	34	3.38	0.001798	0.03101
59P61-101	59PR61-101	72	49	0.32	44	37	34	34	3.38	0.001784	0.04314
59P61-151	59PR61-151	100	68	0.32	30	25	23	34	3.38	0.001770	0.06482
59P61-201	59PR61-201	150	102	0.32	21	18	16	34	3.38	0.001766	0.08642

Add an "R" to the part number after "P" for the RoHS compliant version (i.e. 59PR61-320 is the RoHS compliant version of 59P61-320).

- The Rated Current (I_{rated}) is either the Saturation Current at 25°C or the Temperature Rise Current; the lowest number of the two specified currents.
- The Saturation Current (I_{sat}) is the current at which the Inductance drops by a maximum of 20% below the lower limit of its value specified at 0 ADC Bias. Inductance at I_{sat} is measured at the specified Ambient Temperature by applying DC Bias by a short period of time to minimize the self-heating effect of the component.
- The Temperature Rise Current is the current at which the temperature of the part increases by 50°C. This test is performed with the part mounted on a PCB with traces having 1.7 times the cross sectional area of the copper leads of the part. The temperature of the part is measured after applying the DC current for a minimum of 10 minutes.
- Inductance is measured at 100 KHz and 1.0 Vrms.
- Temperature Rise can be estimated using the following formulas:

$$T_{rise} (°C) = \left(\frac{\text{Core Loss} + \text{DCR Loss}}{\text{TRF A}} \right)^{0.833}$$

$$\text{DCR Loss (mW)} = \left(I_{dc}^2 + \left(\frac{\Delta I}{2} \right)^2 \right) \times \text{TYP DCR (mOhms)}$$

$$\text{Core Loss (mW)} = \text{TRF B} \times (F)^{1.84} \times (\text{TRF C} \times \Delta I)^{2.28}$$

IDC = DC output current (ADC)
 Δ I = Delta I across the inductor (Amps)
 F = Switching frequency (kHz)

SMD High Frequency Power Inductor

Designed for VRM 9.x, 10.x, & 11.x Applications

59PR61-320 Inductance vs. I_{dc}

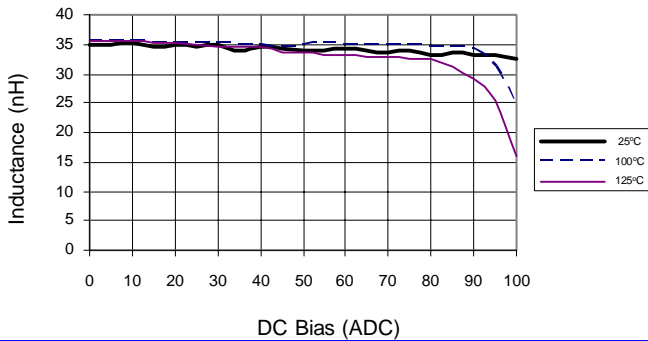

59PR61-580 Inductance vs. I_{dc}

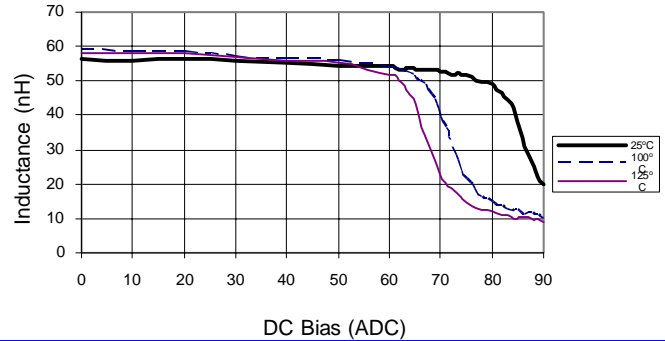

59PR61-720 Inductance vs. I_{dc}

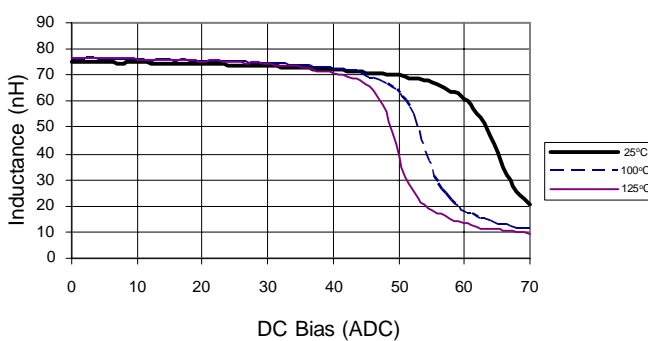

59PR61-101 Inductance vs. I_{dc}

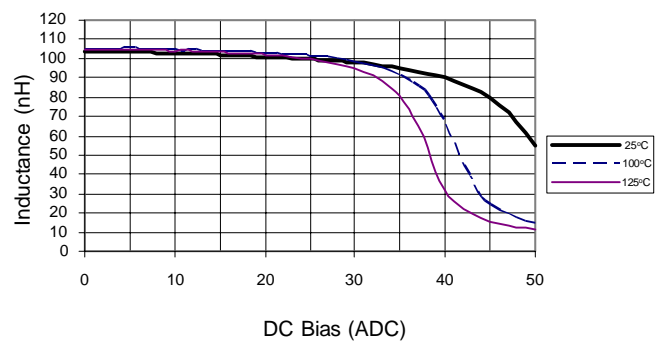

59PR61-151 Inductance vs. I_{dc}

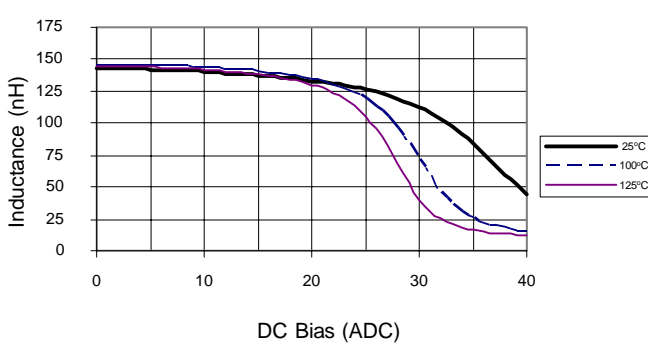

59PR61-201 Inductance vs. I_{dc}

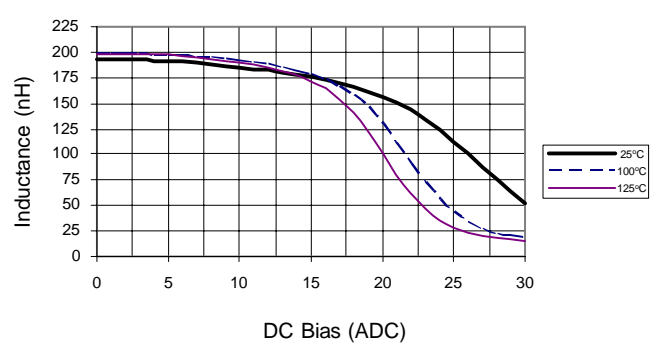

59PR61-XXX Temp. Rise vs. I_{dc}

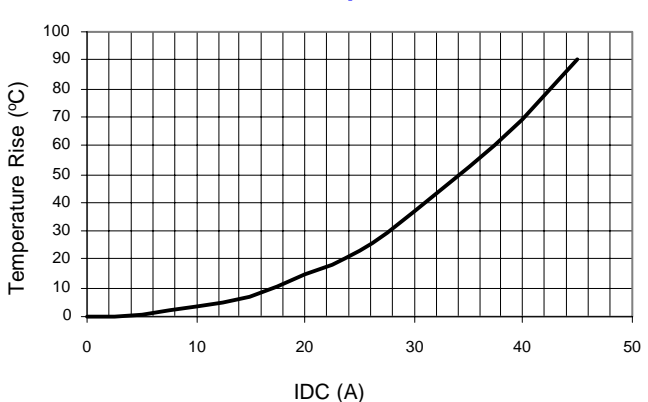

59PR61-XXX R_{dc} vs. Temperature

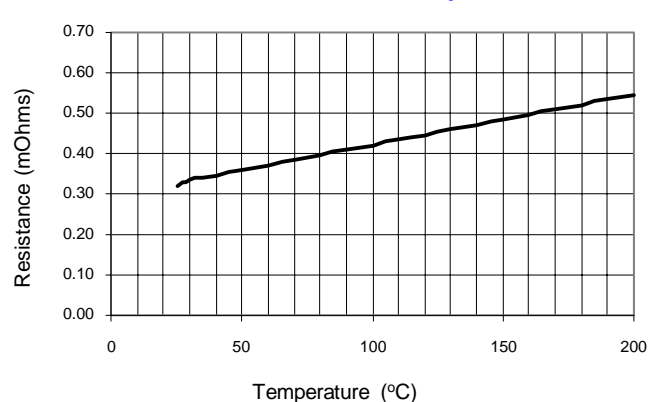

SMD High Frequency Power Inductor

Designed for VRM 9.x, 10.x, & 11.x Applications

IR Profile

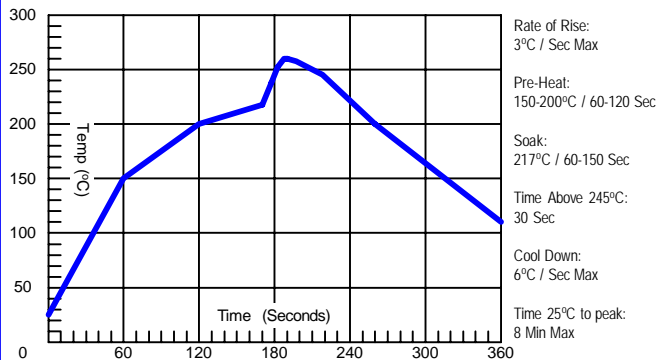

Tape and Reel

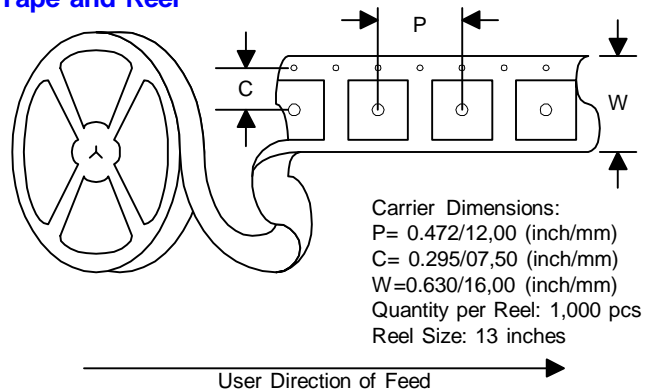

ENVIRONMENTAL & RELIABILITY DATA

Storage Temperature: -40°C to +125°C
Operating Temperature: -40°C to +125°C
Resistance to Solder Reflow: 3 passes thru. +245°C for 30 seconds minimum

Marking permanency: Tested per JESD22-B107-A
Solderability: Tested per MIL-STD-750D
Life Test: Tested per MIL-STD-202F, Method 108A
Thermal Cycle: Tested per JESD22-B104-B, Test Condition G

ABOUT US

Vitec Electronics Corporation, founded in 1986, is a worldwide leader in the design, manufacture and sale of magnetic solutions. Vitec's market focus includes the power, power conditioning, telecom, networking, communications and computing. Vitec has also established strong alliances with chip manufacturers whereby magnetic solutions are designed in conjunction with unique silicon requirements and are offered as reference designs by the chip companies.

With its Corporate Headquarters and Research & Development center located in Carlsbad, California, and its state of the art manufacturing facility and material sourcing in China, Vitec is uniquely positioned to supply the latest technology at the lowest cost. Vitec offers both standard and custom product design capabilities with all of its facilities being ISO certified.

QUALITY POLICY

Vitec will provide products and services that meet or exceed our Customer's requirements, conform to company policies and standards, and exhibit continuously improving levels of Quality.

COMMITMENT

VITEC Electronics empowers each of its employees by providing a business environment that encourages a commitment to excellence, a sense of ownership and personal accountability to all Vitec Customers.

Competitive Pricing, Quality Products, and On Time Deliveries are expected from today's World Class Magnetics Suppliers. The high standards of today's customer are strengthening the dedication and commitment of VITEC Electronics to provide Total Customer Service.

CONTACT US

USA

VITEC ELECTRONICS CORPORATION
6213 El Camino Real
Carlsbad, CA 92009
U.S.A.

TEL: +1 (760) 918-8831
FAX: +1 (760) 918-8840

ASIA

SHANGHAI VITEC ELECTRONICS CO., LTD.
3369 He Chuan Road
Min Hang District, Shanghai, 201103
China

TEL: +86 (21) 6446-4828
FAX: +86 (21) 6446-4865

SMD High Frequency Power Inductor

Designed for VRD & VRM 10.x & 11.x Applications

FEATURES

- Recommended for use with all major Voltage Regulator ICs
- High Current handling capability in the smallest footprint
- Up to 2MHz operating frequency
- Extended operating temperature range: -40°C to 125°C
- Robust SMD package capable of handling the most aggressive SMT assembly process
- RoHS compliant
- 100% tested to a 10% DCR tolerance

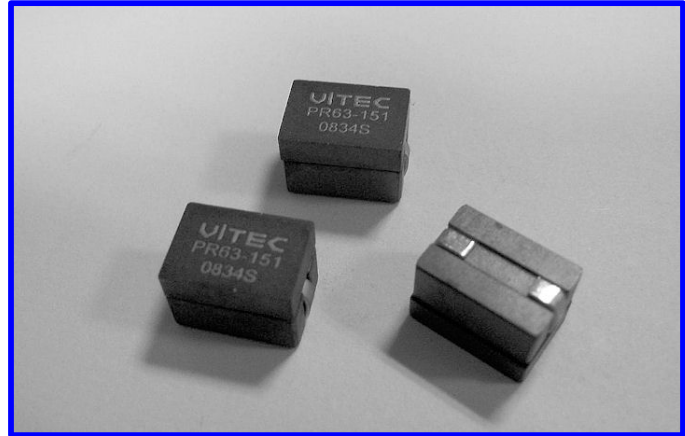

APPLICATIONS

- VRD and VRM 10.x and 11.x based designs
- Multi-Phase Voltage regulator designs
- Server, Desktop, PDA, Graphics cards, Notebook computers, DDR, telecom switches and routers
- DC-DC converters, Battery powered devices, high current power supplies
- High Current NPUs in networking equipment
- Point-of-load Modules
- DCR sensing

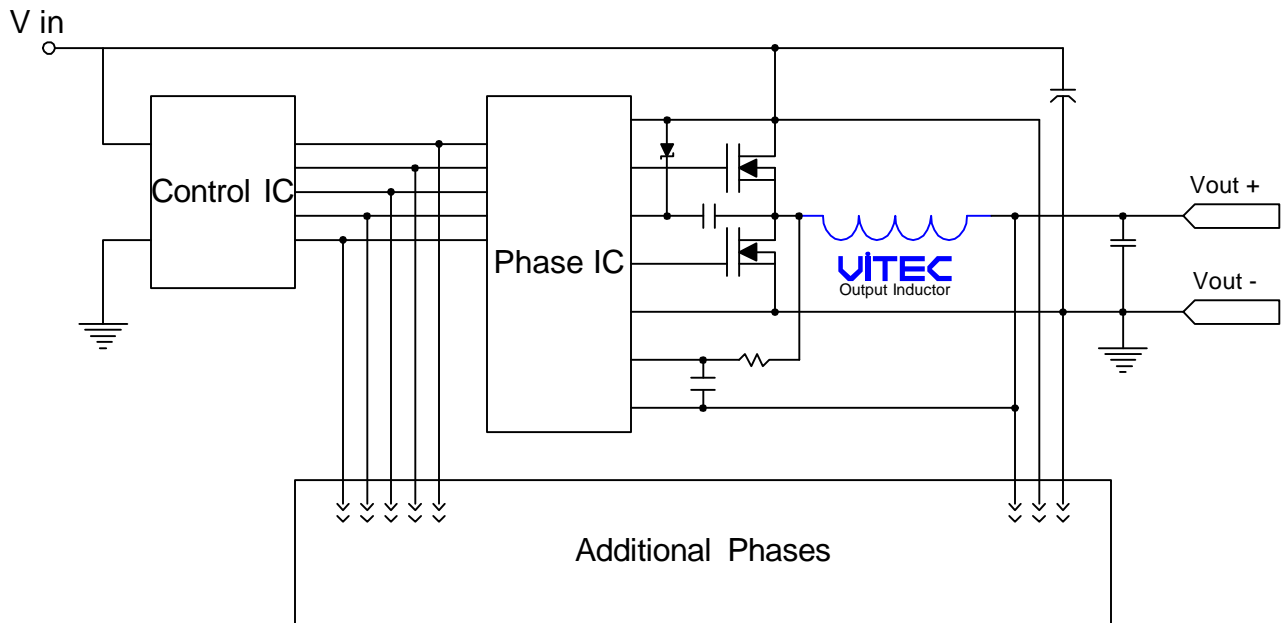

Typical Multi-Phase Application Circuit for a Buck Converter

SMD High Frequency Power Inductor

Designed for VRD & VRM 10.x & 11.x Applications

PACKAGE

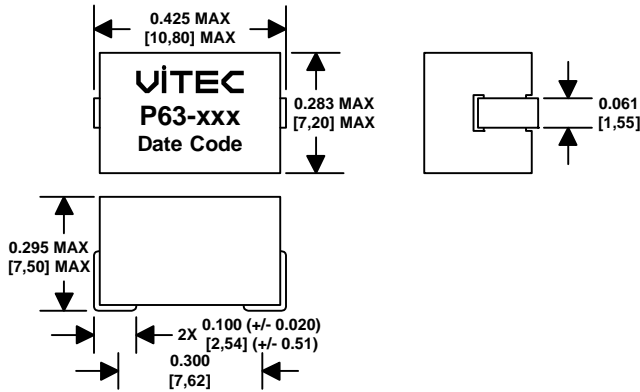

Dimensions: Inches [mm]. Tolerances: +/- 0.005" [0,13mm] unless otherwise noted

SCHEMATIC

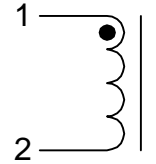

SUGGESTED PCB LAYOUT

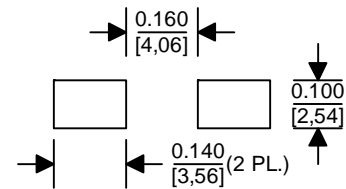

Drawing NOT to scale

ELECTRICAL CHARACTERISTICS @ 25°C (unless otherwise noted)

Part Number		Inductance ⁴ @ 0 Adc	Inductance ⁴ @ Isat ² (25°C)	DCR	Isat ² (Max Saturation Current)			Temp. Rise Current ³	Temp. Rise Factor A (TRF A) ⁵	Temp. Rise Factor B (TRF B) ⁵	Temp. Rise Factor C (TRF C) ⁵
					ADC						
Classic	RoHS	± 15%	MIN	± 10%	25°C	100°C	125°C	ADC MAX			
59P63-700	59PR63-700	70	48	0.47	137	122	118	35	5.26	0.004611	0.01347
59P63-121	59PR63-121	120	82	0.47	80	70	68	35	5.26	0.004482	0.02328
59P63-151	59PR63-151	150	102	0.47	63	56	54	35	5.26	0.004450	0.02914
59P63-231	59PR63-231	230	156	0.47	41	36	35	35	5.26	0.004403	0.04477
59P63-301	59PR63-301	300	204	0.47	32	28	27	35	5.26	0.004387	0.05843
59P63-401	59PR63-401	400	272	0.47	23	20	19	35	5.26	0.004375	0.07792
59P63-511	59PR63-511	510	346	0.47	17	15	14	35	5.26	0.004367	0.09936

Add an "R" to the part number after "P" for the RoHS compliant version (i.e. 59PR63-700 is the RoHS compliant version of 59P63-700).

- The Rated Current (Irated) is either the Saturation Current at 25°C or the Temperature Rise Current ; the lowest number of the two specified currents.
- The Saturation Current (Isat) is the current at which the Inductance drops by a maximum of 20% below the lower limit of its value specified at 0 ADC Bias. Inductance at Isat is measured at the specified Ambient Temperature by applying DC Bias by a short period of time to minimize the self-heating effect of the component.
- The Temperature Rise Current is the current at which the temperature of the part increases by 50°C. This test is performed with the part mounted on a PCB with traces having 1.7 times the cross sectional area of the copper leads of the part. The temperature of the part is measured after applying the DC current for a minimum of 10 minutes.
- Inductance is measured at 100 KHz and 1.0 Vrms.
- Temperature Rise can be estimated using the following formulas:

$$T_{rise} (^{\circ}C) = \left(\frac{\text{Core Loss} + \text{DCR Loss}}{\text{TRF A}} \right)^{0.833}$$

$$\text{DCR Loss (mW)} = \left(I_{dc}^2 + \left(\frac{\Delta I}{2} \right)^2 \right) \times \text{TYP DCR (mOhms)}$$

$$\text{Core Loss (mW)} = \text{TRF B} \times (F)^{1.84} \times (\text{TRF C} \times \Delta I)^{2.28}$$

I_{DC} = DC output current (ADC)
 ΔI = Delta I across the inductor (Amps)
 F = Switching frequency (kHz)

SMD High Frequency Power Inductor

Designed for VRD & VRM 10.x & 11.x Applications

59PR63-700 Inductance vs. I_{dc} @ 25°C

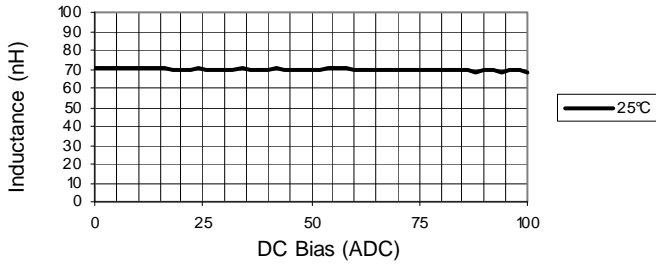

59PR63-121 Inductance vs. I_{dc} @ 25°C

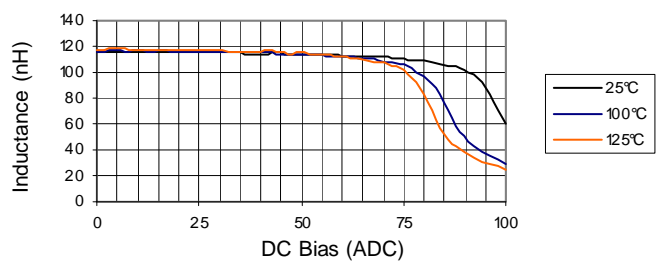

59PR63-151 Inductance vs. I_{dc} @ 25°C

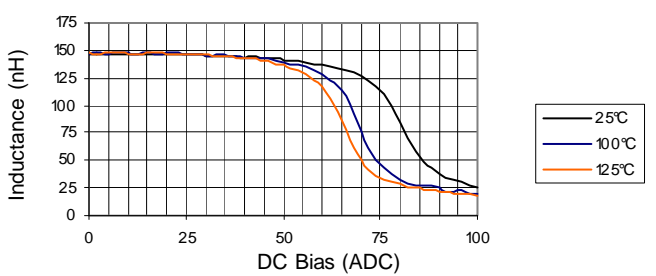

59PR63-231 Inductance vs. I_{dc} @ 25°C

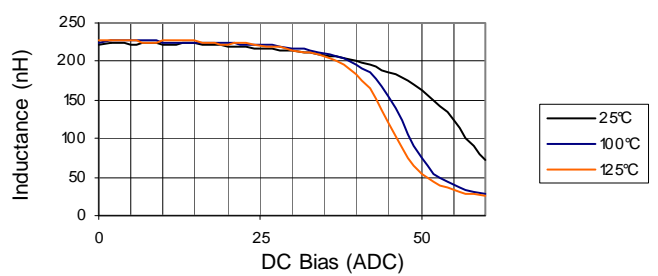

59PR63-301 Inductance vs. I_{dc} @ 25°C

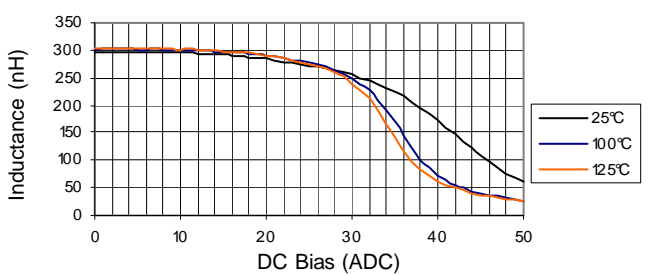

59PR63-401 Inductance vs. I_{dc} @ 25°C

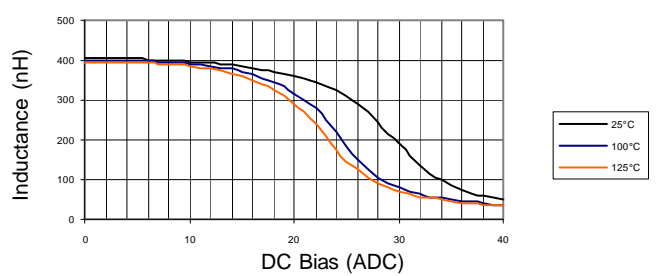

59PR63-511 Inductance vs. I_{dc} @ 25°C

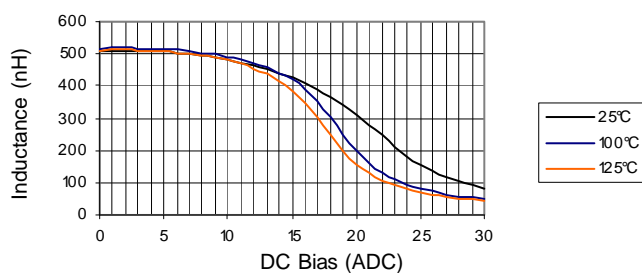

59PR63 Temp. Rise vs. I_{dc}

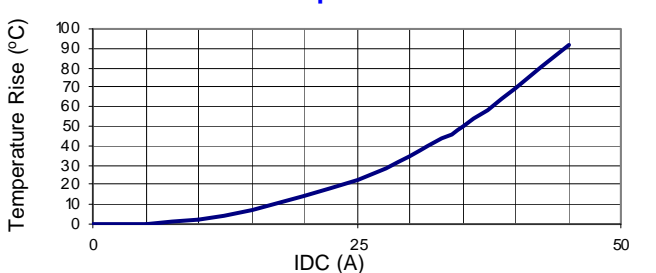

59PR63 R_{dc} vs. Temp. Rise

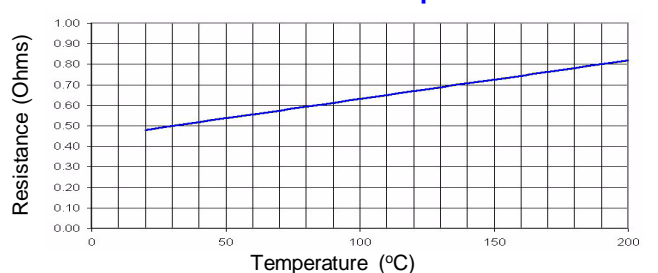

SMD High Frequency Power Inductor

Designed for VRD & VRM 10.x & 11.x Applications

IR Profile

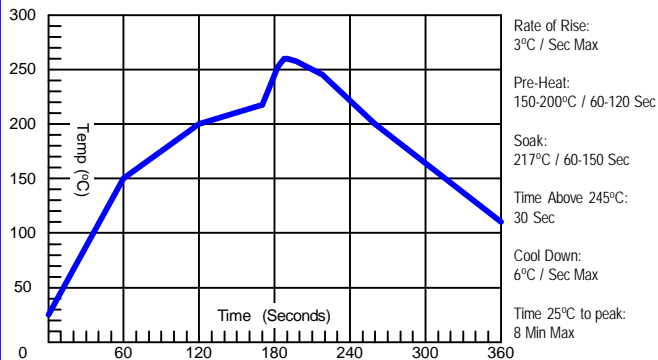

Tape and Reel

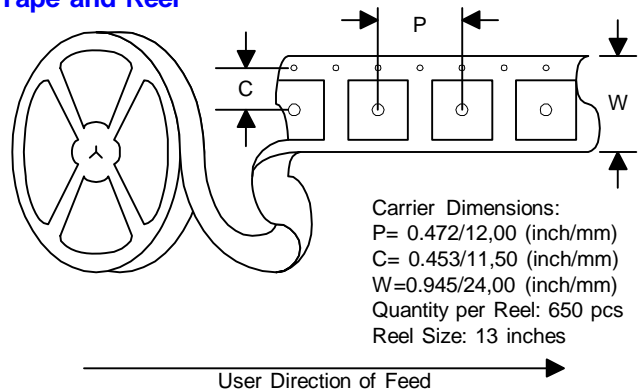

ENVIRONMENTAL & RELIABILITY DATA

Storage Temperature: -40C to +125C
Operating Temperature: -40C to +125C
Resistance to Solder Reflow: 3 passes thru. +235C for 30 seconds minimum

Marking permanency: Tested per JESD22-B107-A
Solderability: Tested per MIL-STD-750D
Life Test: Tested per MIL-STD-202F, Method 108A
Thermal Cycle: Tested per JESD22-B104-B, Test Condition G

ABOUT US

Vitec Electronics Corporation, founded in 1986, is a worldwide leader in the design, manufacture and sale of magnetic solutions. Vitec's market focus includes the power, power conditioning, telecom, networking, communications and computing. Vitec has also established strong alliances with chip manufacturers whereby magnetic solutions are designed in conjunction with unique silicon requirements and are offered as reference designs by the chip companies.

With its Corporate Headquarters and Research & Development center located in Carlsbad, California, and its state of the art manufacturing facility and material sourcing in China, Vitec is uniquely positioned to supply the latest technology at the lowest cost. Vitec offers both standard and custom product design capabilities with all of its facilities being ISO certified.

QUALITY POLICY

Vitec will provide products and services that meet or exceed our Customer's requirements, conform to company policies and standards, and exhibit continuously improving levels of Quality.

COMMITMENT

VITEC Electronics empowers each of its employees by providing a business environment that encourages a commitment to excellence, a sense of ownership and personal accountability to all Vitec Customers.

Competitive Pricing, Quality Products, and On Time Deliveries are expected from today's World Class Magnetics Suppliers. The high standards of today's customer are strengthening the dedication and commitment of VITEC Electronics to provide Total Customer Service.

CONTACT US

USA

VITEC ELECTRONICS CORPORATION
6213 El Camino Real
Carlsbad, CA 92009
U.S.A.

TEL: +1 (760) 918-8831
FAX: +1 (760) 918-8840

ASIA

SHANGHAI VITEC ELECTRONICS CO., LTD.
3369 He Chuan Road
Min Hang District, Shanghai, 201103
China

TEL: +86 (21) 6446-4828
FAX: +86 (21) 6446-4865

SMD High Frequency Power Inductor

Designed for VRM 9.x, 10.x, & 11.x Applications

FEATURES

- Recommended for use with all major Voltage Regulator ICs.
- Low DCR for best efficiency.
- Operating frequency of 0.100 - 2.0 MHz.
- Extended operating temperature range: -40°C to 125°C.
- High current handling capability.
- Robust SMD package capable of handling the most aggressive SMT assembly process.
- RoHS compliant version available.

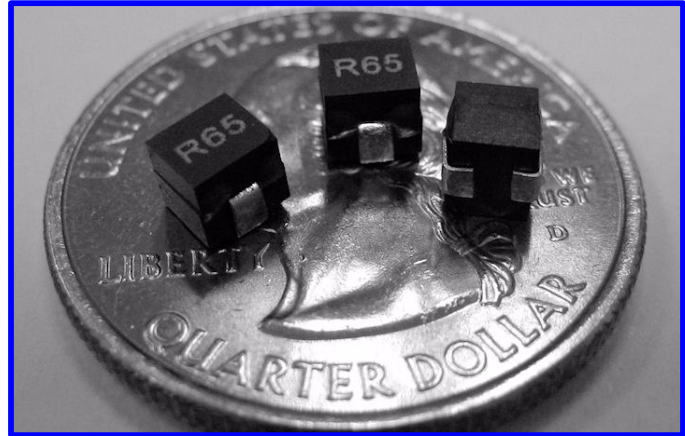

APPLICATIONS

- VRM 9.x, 10.x, and 11.x based designs
- Multi-Phase Voltage regulator designs
- Server, Desktop, PDA, Graphics cards, Notebook computers, DDR, telecom switches and routers
- DC-DC converters, Battery powered devices, high current power supplies
- High Current NPUs in networking equipment
- Point-of-load Modules
- DCR sensing

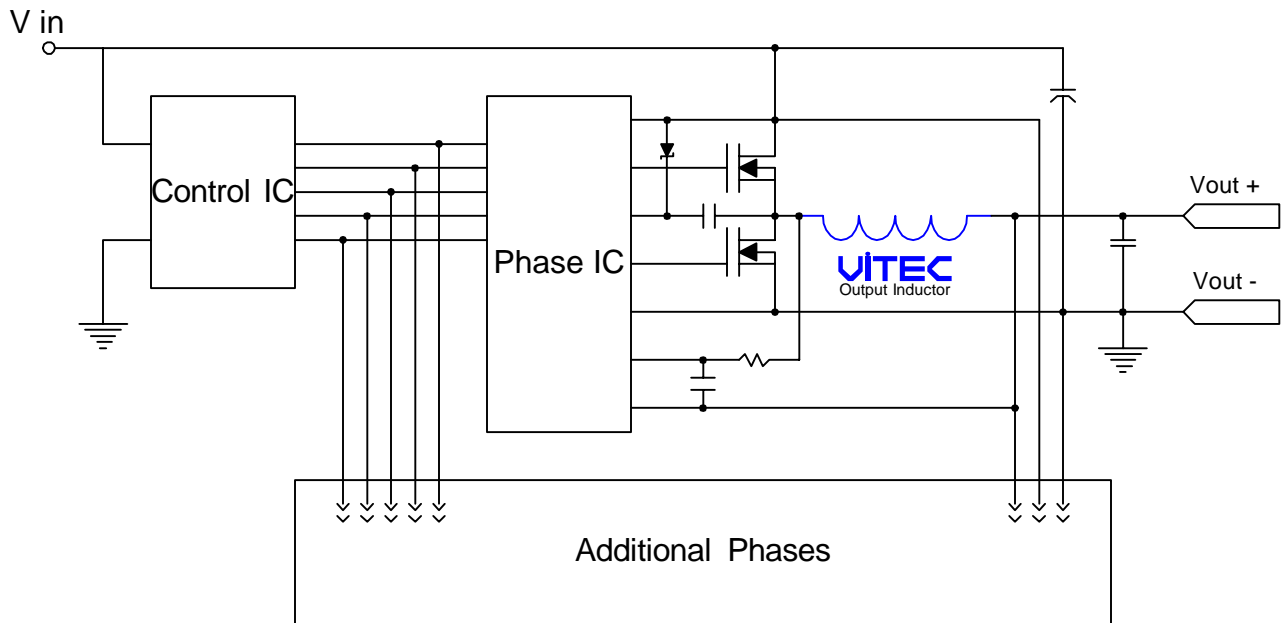

Typical Multi-Phase Application Circuit for a Buck Converter

SMD High Frequency Power Inductor

Designed for VRM 9.x, 10.x, & 11.x Applications

PACKAGE

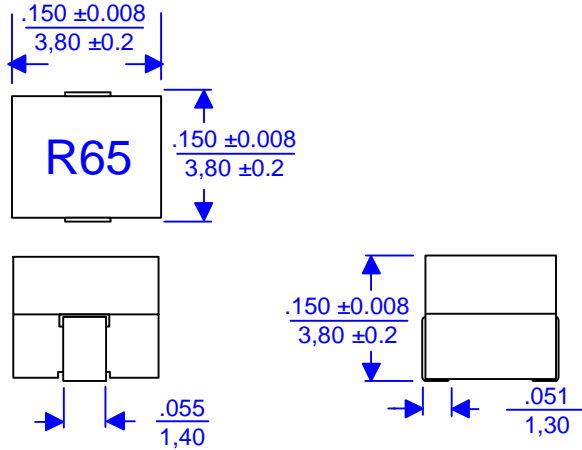

Dimensions: Inches [mm]. Tolerances: +/- 0.005" [0,13mm] unless otherwise noted

SCHEMATIC

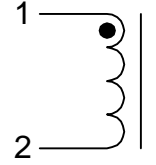

SUGGESTED PCB LAYOUT

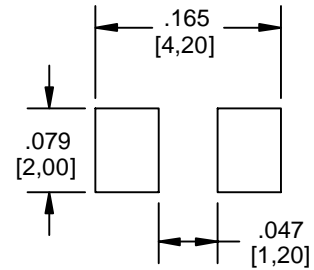

Drawing NOT to scale

ELECTRICAL CHARACTERISTICS @ 25°C (unless otherwise noted)

Part Number		Inductance @ 0 ADC (4)	Inductance @ Irated (4)	Irated (1)	DCR		Isat Max Saturation Current (2)			Temp. Rise Current (3)	Temp. Rise Factor C (5)
		nH	nH	ADC	mOhm		ADC	ADC	ADC	ADC	
Classic	RoHS	± 15%	MIN	MAX	TYP	MAX	-40°C	25°C	125°C	MAX	
59P65-650	59PR65-650	65	44	24	0.32	0.40	25	24	18	19	0.0004237

Add an "R" to the part number after "P" for the RoHS compliant version (i.e. 59PR65-650 is the RoHS compliant version of 59P65-650).

- The Rated Current (Irated) is either the Saturation Current at 25°C.
- The Saturation Current (Isat) is the current at which the Inductance drops by a maximum of 20% below the lower limit of its value specified at 0 ADC Bias. Inductance at Isat is measured at the specified Ambient Temperature by applying DC Bias by a short period of time to minimize the self-heating effect of the component.
- The Temperature Rise Current is the current at which the temperature of the part increases by 50°C. This test is performed with the part mounted on a PCB with 0.400" wide, 0.006" thick copper traces and applying the DC current for a minimum of 30 minutes.
- Inductance is measured at 100 KHz and 1.0 Vrms.
- Temperature Rise can be estimated using the following formulas:

$$T_{rise} (°C) = \left(\frac{\text{Core Loss} + \text{DCR Loss}}{0.61} \right)^{0.833}$$

$$\text{DCR Loss (mW)} = \left(I_{dc}^2 + \left(\frac{\Delta I}{2} \right)^2 \right) \times \text{TYP DCR (mOhms)}$$

$$\text{Core Loss (mW)} = 0.073389 \times (F)^{1.84} \times (\text{TRF C} \times \Delta I)^{2.28}$$

IDC = DC output current (ADC)
 ΔI = Delta I across the inductor (Amps)
 F = Switching frequency (kHz)

SMD High Frequency Power Inductor

Designed for VRM 9.x, 10.x, & 11.x Applications

59PR65-650 Inductance vs. DC Bias @ 25°C

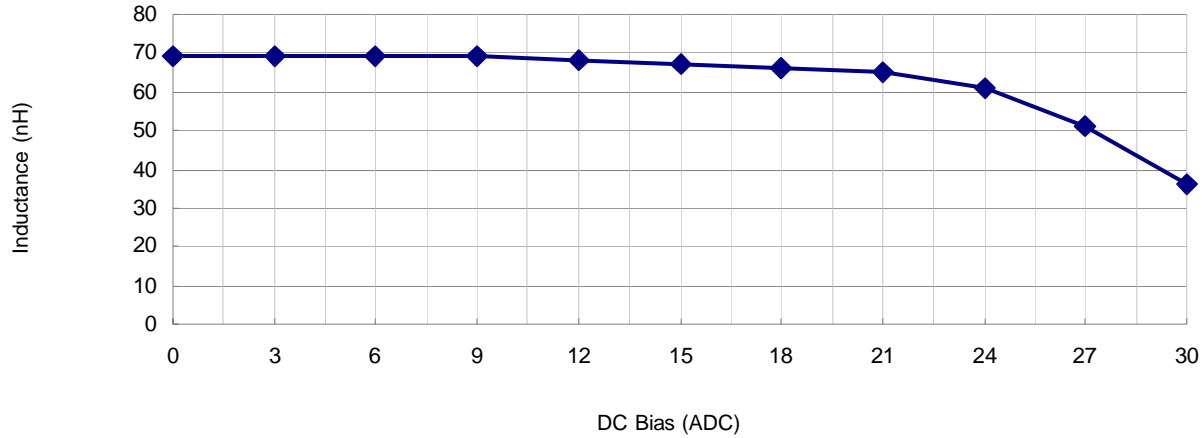

59PR65-650 Temperature Rise vs. DC Bias

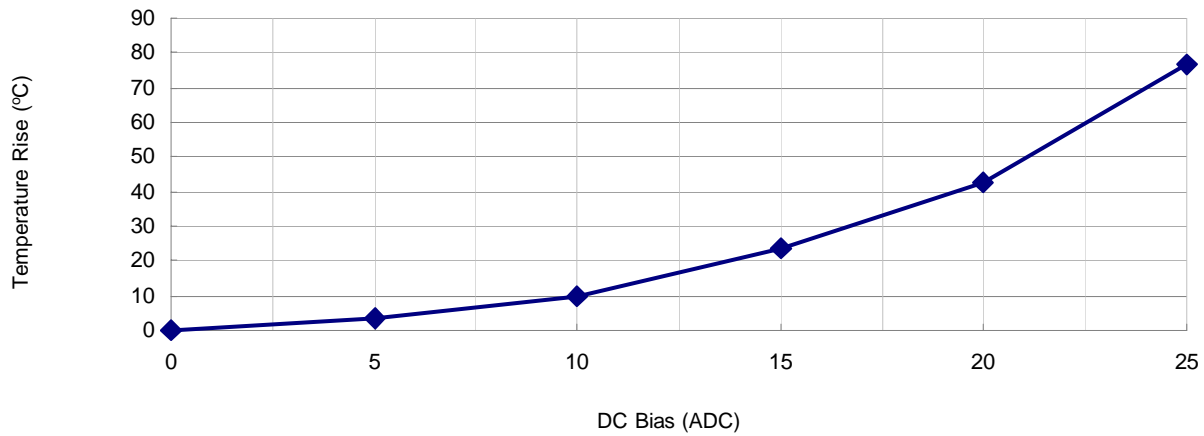

59PR65-650 DCR vs. DC Bias

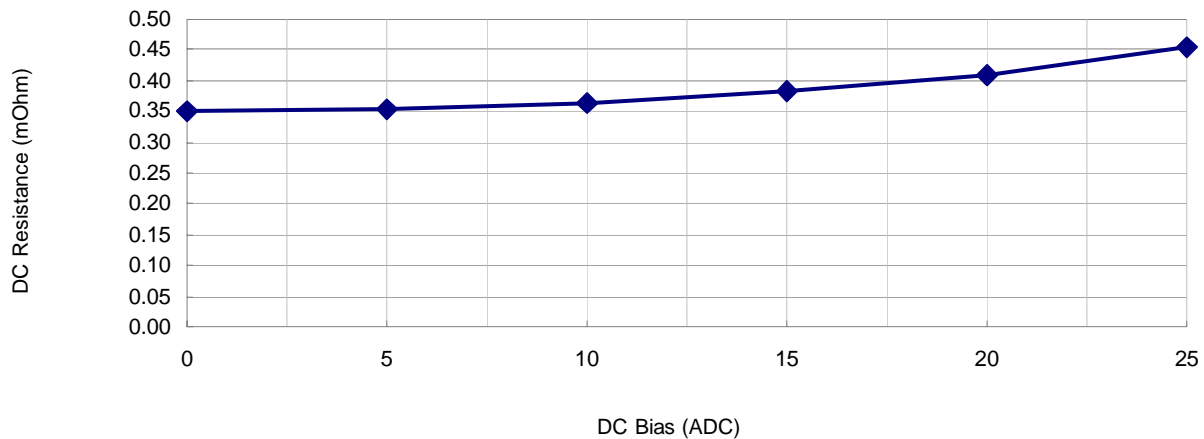

SMD High Frequency Power Inductor

Designed for VRM 9.x, 10.x, & 11.x Applications

IR Profile

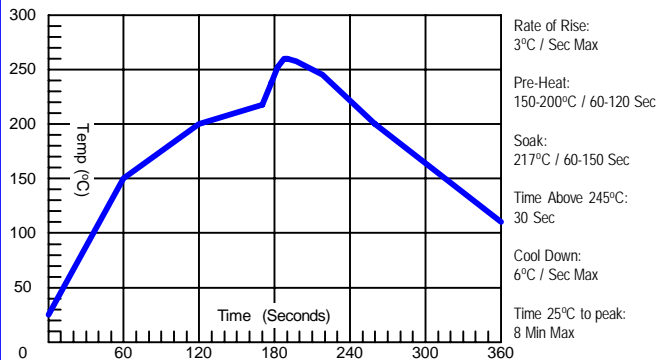

Tape and Reel

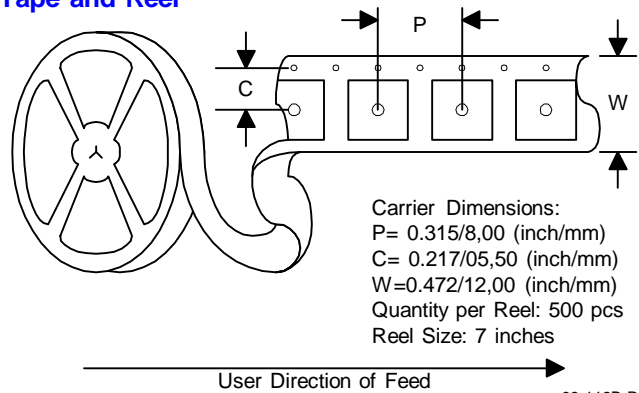

ENVIRONMENTAL & RELIABILITY DATA

Storage Temperature: -40°C to +125°C
Operating Temperature: -40°C to +125°C
Resistance to Solder Reflow: 3 passes thru. +245°C for 30 seconds minimum

Marking permanency: Tested per JESD22-B107-A
Solderability: Tested per MIL-STD-750D
Life Test: Tested per MIL-STD-202F, Method 108A
Thermal Cycle: Tested per JESD22-B104-B, Test Condition G

ABOUT US

Vitec Electronics Corporation, founded in 1986, is a worldwide leader in the design, manufacture and sale of magnetic solutions. Vitec's market focus includes the power, power conditioning, telecom, networking, communications and computing. Vitec has also established strong alliances with chip manufacturers whereby magnetic solutions are designed in conjunction with unique silicon requirements and are offered as reference designs by the chip companies.

With its Corporate Headquarters and Research & Development center located in Carlsbad, California, and its state of the art manufacturing facility and material sourcing in China, Vitec is uniquely positioned to supply the latest technology at the lowest cost. Vitec offers both standard and custom product design capabilities with all of its facilities being ISO certified.

QUALITY POLICY

Vitec will provide products and services that meet or exceed our Customer's requirements, conform to company policies and standards, and exhibit continuously improving levels of Quality.

COMMITMENT

VITEC Electronics empowers each of its employees by providing a business environment that encourages a commitment to excellence, a sense of ownership and personal accountability to all Vitec Customers.

Competitive Pricing, Quality Products, and On Time Deliveries are expected from today's World Class Magnetics Suppliers. The high standards of today's customer are strengthening the dedication and commitment of VITEC Electronics to provide Total Customer Service.

CONTACT US

USA

VITEC ELECTRONICS CORPORATION
6213 El Camino Real
Carlsbad, CA 92009
U.S.A.

TEL: +1 (760) 918-8831
FAX: +1 (760) 918-8840

ASIA

SHANGHAI VITEC ELECTRONICS CO., LTD.
3369 He Chuan Road
Min Hang District, Shanghai, 201103
China

TEL: +86 (21) 6446-4828
FAX: +86 (21) 6446-4865

STANDARD MAGNETICS

INDUSTRIES

- Monitoring
- Metering
- Computing
- Industrial
- Telecom
- Power Protection
- Consumer
- Medical
- Networking
- Audio/Visual
- Test & Measurement
- Automation

PRODUCTS/ SYSTEMS

- Power Meters
- Power Distribution
- Test Equipment
- HVAC
- Motion Control
- PCs
- Welders
- Back-up
- UPS
- Laptops
- PDAs
- Appliances
- Scanners
- Heat Exchange
- Security Systems

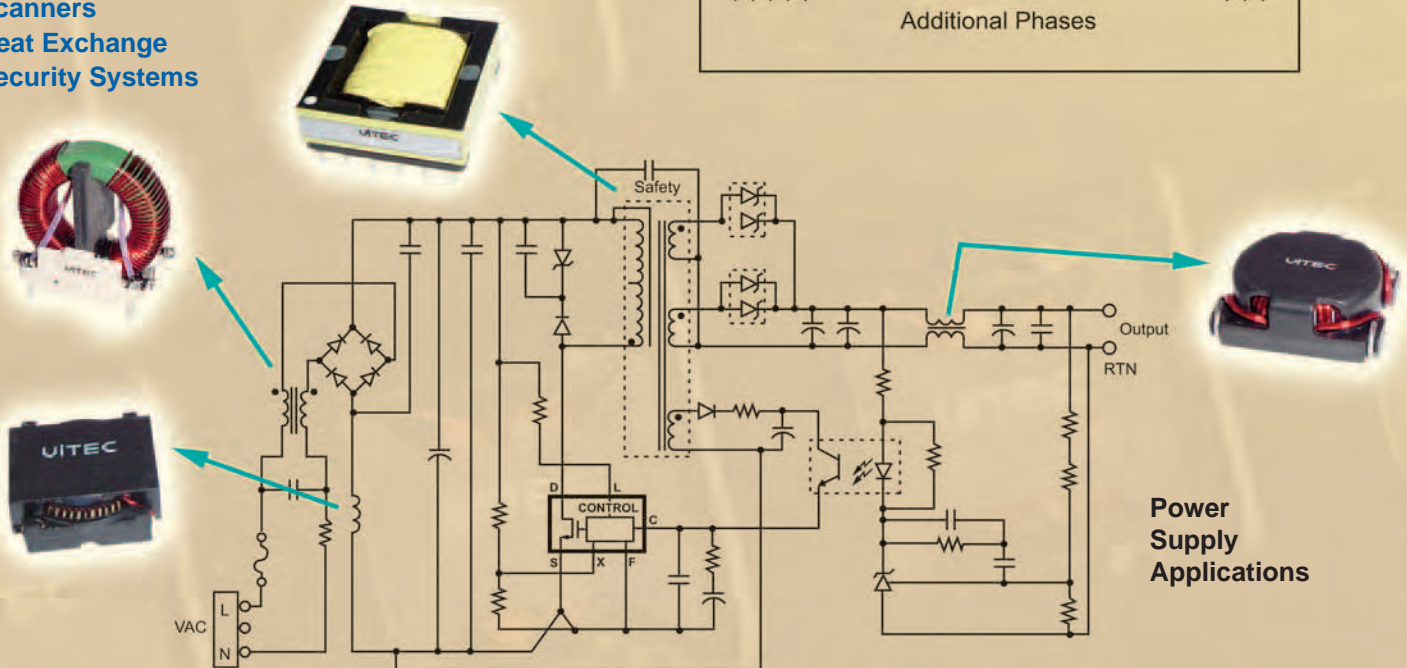
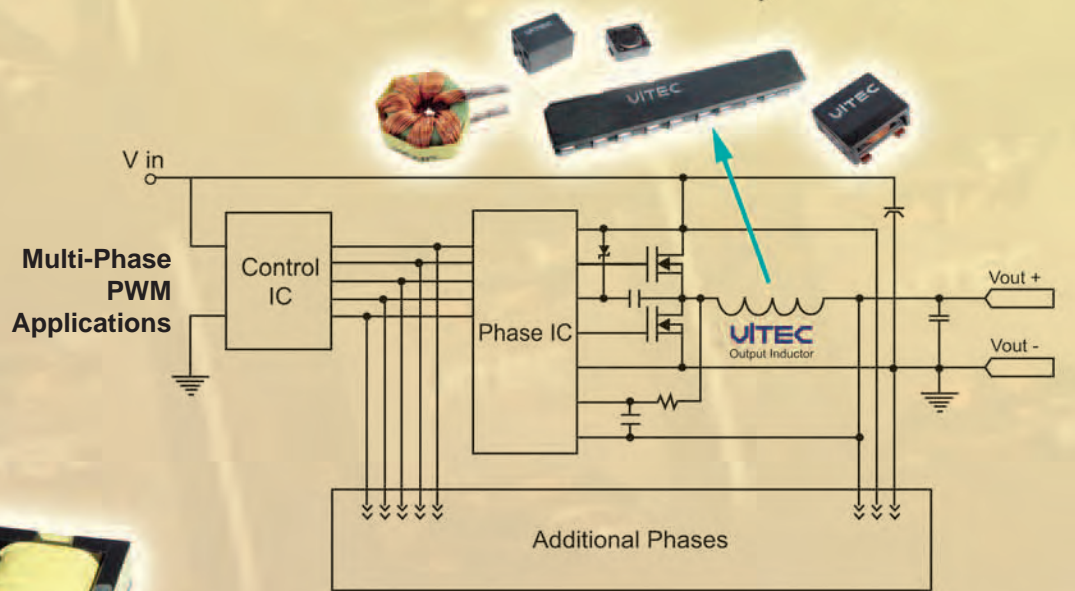
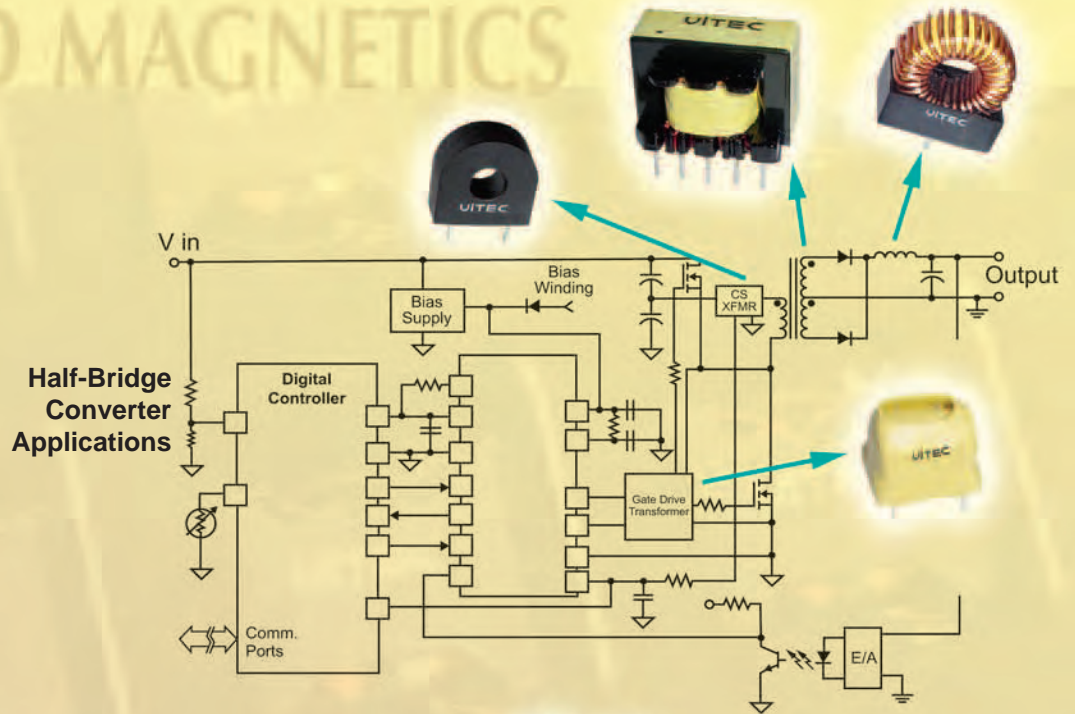



WWW.VITECCORP.COM



USA OPERATIONS (H.Q.)

Vitec Electronics Corporation

6213 El Camino Real
Carlsbad, CA 92009
TEL: (760) 918-8831
FAX: (760) 918-8840
Sales@viteccorp.com

ASIAN OPERATIONS

Vitec Shanghai Electronics

3369 He Chuan Road
Shanghai 201103, China
TEL: 86(21) 6446-4828
FAX: 86(21) 6446 4865

VITEC'S COMMITMENT TO QUALITY

Vitec is committed to designing, manufacturing, shipping and processing all aspects of our business to the highest quality standards. Vitec employees are empowered to provide products and services that meet or exceed our Customers' requirements, conform to company policies and standards, and exhibit continuously improving levels of Quality.

CERTIFICATIONS

- UL Insulation System (E107307) supporting temperature Class B (130° C) to Class X (180° C).
- Vitec can provide designs to meet UL, CSA, TUV, BABT and VDE requirements.
 - ISO 9001:2000 certified for corporate and manufacturing facilities.



FM39780 – Corporate
FM59195 – Factory
ISO 9001:2000 Certified