

VITEC

Communication Products

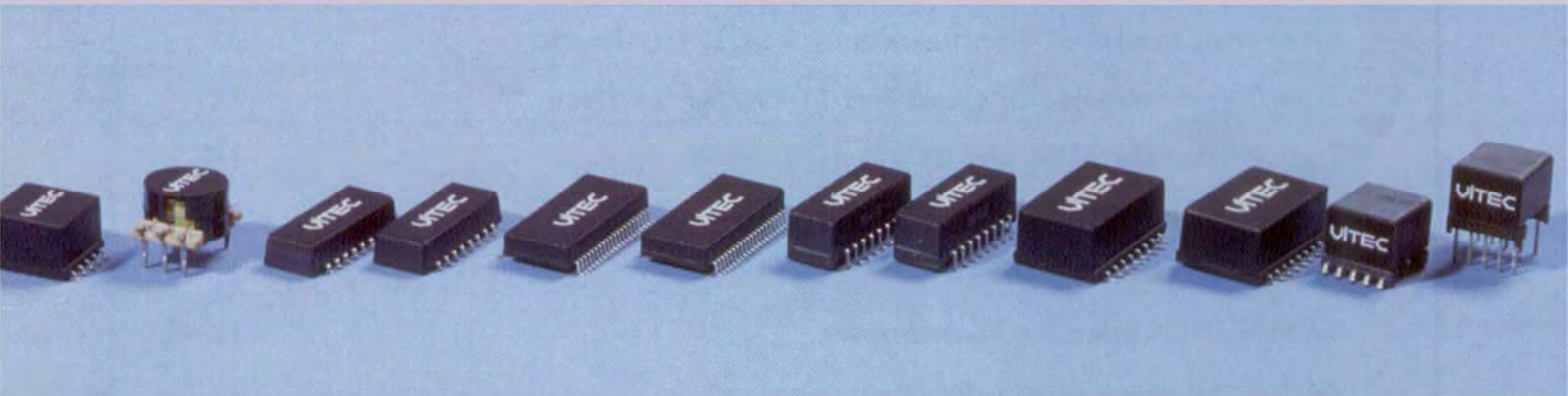

T1/E1/CEPT/ISDN/PRI
T3/DS3/E3/STS-1
ISDN S/T, U
HDSL, ADSL, DDS
Ethernet/Fast Ethernet
Digital Audio/Broad Band Access
Common Mode Chokes

INNOVATIONS IN MAGNETICS

WELCOME TO VITEC ELECTRONICS

Founded in 1986, Vitec is a leading manufacturer of transformer products and magnetic components for the electronics industry. With headquarters in Carlsbad, California and manufacturing facilities in Shanghai, China, Vitec has a wide range of capabilities available to its customers, including support for JIT and Dock-to-Stock programs. Vitec is committed to quality through continuous, careful attention to material management, product design, application engineering and reliable, consistent manufacturing processes. Put our field-proven expertise to work on your next project.



Brad Rogers
General Manager

Vitec's operations include authorized distributorships and representative sales offices worldwide. Sales management in the continental United States, Puerto Rico, Canada, Mexico, Brazil, and Europe are conducted from corporate headquarters in Carlsbad, California, and for all of Asia from Shanghai, China.



Shanghai
China

Carlsbad
California



Vitec Shanghai Electronics



DESIGN & DEVELOPMENT

Vitec's comprehensive, in-house tooling capability – including jigs, fixtures and automation equipment – combined with the use of innovative materials such as iron powder, ferrite, MPP and Sandust, ensure the most cost-effective solution to your yield and performance objectives. Our product capability ranges from high-volume standard surface-mount and thru-hole inductors to short-run, high-power custom transformers. Our highly trained and dedicated engineering, technical and customer-support staff will oversee your project from design and prototyping through production and delivery, ensuring the highest standards of product performance, consistency and reliability.

COMMUNICATIONS PRODUCTS

TABLE OF CONTENTS

DESCRIPTION	PAGE
Transformer Selection Guide - LAN Transceiver Chips	6
Transformer Selection Guide - T1/E1 Interface	15
Transformer Selection Guide - ADSL Transceiver Chips	24
Transformer Selection Guide - T3/DS3/E3/STS-1	27
Transformer Selection Guide - ISDN-S Interface	33
Transformer Selection Guide - ISDN-S Interface	34
Transformer Selection Guide - ISDN-S Interface	37
Transformer Selection Guide - ISDN-U Interface	39
Transformer Selection Guide - ISDN-U Interface	42
Transformer Selection Guide - ISDN-U Interface	43
Transformer Selection Guide - HDSL Transceiver Chips	45
Pulse Transformers	1
Low Profile Transformers for DC/DC Converters	5
Isolation Transformer for Ethernet/10Base-T	7
Transformer Modules for Quad Port 10Base-T	10
Transformer Modules for 10/100 Base-Tx	11
Transformer Modules for High Speed LAN	13
SMD Transformers for T1/E1 Interface	16
Extended Temperature Transformers for T1/E1 Interface	18
Standard Temperature Transformers for T1/E1 Interface	19
Reinforced Insulation Transformers for T1/CEPT/ISDN-PRI	22
Transformer Modules for Quad Port T1/E1/DS1 Interface	23
Transformers for ADSL Applications	25
Transformers for ADSL and RADSL Applications	26
Interface Transformers for T3/E3/DS3/STS-1 Applications	28
ISDN-S Interface Transformers	30
64 Kbps, DDS Interface Transformers	38
ISDN-U Interface Transformers	39
ISDN-Upo, ISDN-Upn Interface Transformers	44
Isolation Transformers for HDSL Interface	46
Transformers for HDSL and POTS Splitters Applications	47
Common Mode Chokes for LAN and Telecom Applications	48

SMD & DIP RF/PULSE TRANSFORMERS

Wideband RF and General Purpose Applications

FEATURES

- Designed for use in 50 Ohm wideband RF and fast rise time pulse applications.
- Standard 6 pins DIP or SMD package.
- Dielectric test voltage: 1500 Vrms MIN.
- Operating temperature: 0°C to 70°C.
- Low cost.

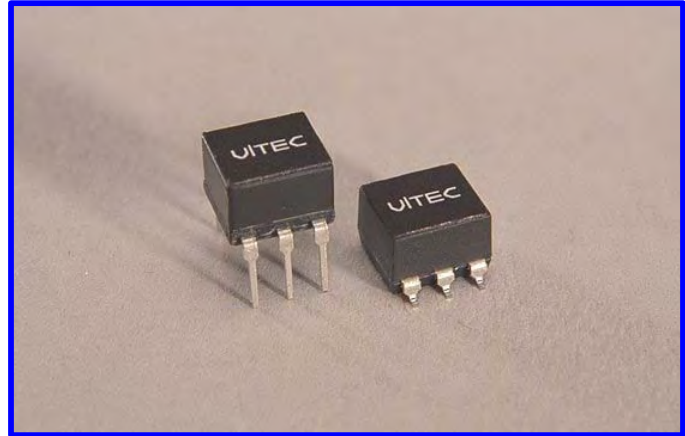

<p>PACKAGE 1</p> <p>Leads are: .010 x .020 x .25 x .51</p> <p>Dimensions Inches/mm +/- 0.01" Unless noted</p>	<p>SCHEMATIC A</p> <p>2 Windings</p>
<p>PACKAGE 2</p> <p>Dimensions Inches/mm +/- 0.01" Unless noted</p> <p>Pad Layout</p>	<p>SCHEMATIC B</p> <p>2 Windings with Center Tap</p>
<p>SCHEMATIC C</p> <p>2 Windings with Secondary CT</p>	

ELECTRICAL CHARACTERISTICS @ 25°C

Part Number		Turns Ratio	LP	LL	Cc	DCR		3 dB Bandwidth		ET Constant	Package & Schematic	
						PRI	SEC	Mhz	Mhz			
DIP	SMD	+/- 5%	uH MIN	uH MAX	pF MAX			TYP	TYP	VuS MIN	DIP	SMD
14Z3235	26Z035	1:1	40	0.15	12	0.20	0.20	0.05	110	2.5	1A	2A
14Z3236	26Z036	1CT:1CT	40	0.18	15	0.20	0.20	0.05	90	2.5	1B	2B
14Z3237	26Z037	1:2CT	25	0.14	15	0.20	0.30	0.10	110	2.0	1C	2C
14Z3238	26Z038	1:1.41CT	40	0.20	18	0.20	0.30	0.05	80	2.5	1C	2C
14Z3239	26Z039	1:4CT	10	0.10	10	0.20	0.60	0.20	60	1.25	1C	2C
14Z3246	26Z046	1CT:1CT	80	0.18	15	0.20	0.20	0.05	90	2.5	1B	2B

Notes: -

TYPE 16Z - 2 WATT PULSE TRANSFORMERS

General Purpose Applications

FEATURES

- Wide range of inductances for a variety of circuit applications.
- Small physical size, pre-molded case design.
- Epoxy encapsulated construction.
- High flux density capability.
- Low cost.

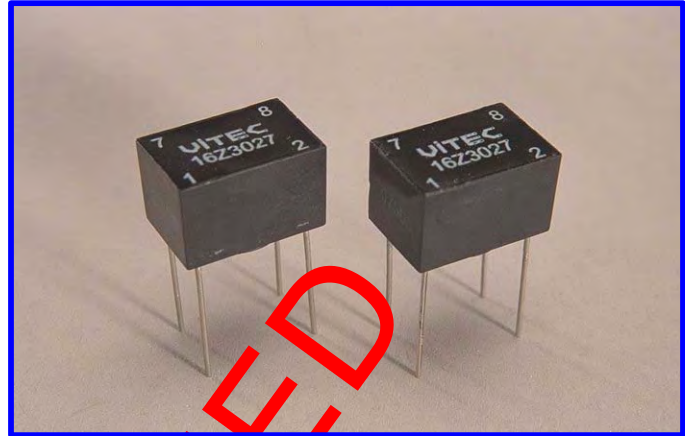

PACKAGE

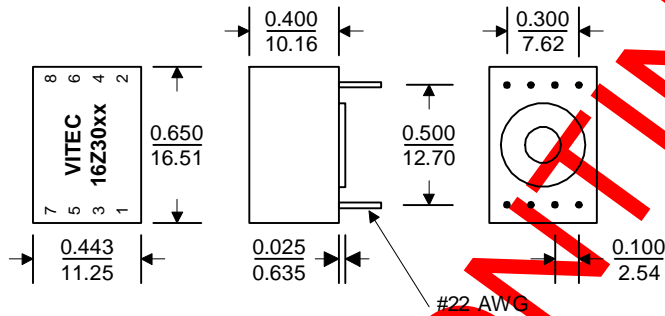

Dimensions Inches/mm +/- 0.01" Unless noted

SCHEMATIC A

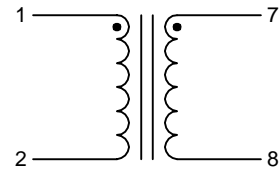

SCHEMATIC B

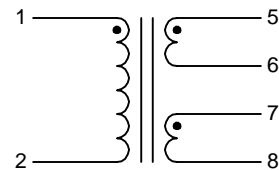

ELECTRICAL CHARACTERISTICS @ 25°C

Part Number	Turns Ratio +/- 5%	LP	ET Constant	Rise Time	Pri/Sec Cc	Pri/Sec LL	DCR (Pri)	DCR (Sec)	DCR (Ter)	Dielectric Test	Schematic
		mH MIN	Vs MIN	nS MAX	pF MAX	uH MAX	Ohms MAX	Ohms MAX	Ohms MAX	Vrms MAX	
16Z3027	1:1	0.5	46	8	26	3.5	1.3	1.4	--	700	A
16Z3028	1:1	1.3	84	30	40	6.0	3.6	3.8	--	700	A
16Z3029	1:1:1	1.3	91	30	38	3.2	3.6	3.8	3.9	700	B
16Z3030	1:2	1.0	70	50	36	2.2	1.4	3.1	--	700	A
16Z3031	1:1:1	5.0	196	70	35	13.0	8.8	9.6	11.0	1500	B
16Z3043	1:1	20.0	250	80	87	10.5	27.0	28.0	--	700	A
16Z3044	4:1:4	0.2	53	50	17	5.7	1.2	0.2	1.3	700	B

TYPE 16Z - 500 mW PULSE TRANSFORMERS

General Purpose Applications

FEATURES

- Wide range of inductances for a variety of circuit applications.
- Small physical size, pre-molded T-case design.
- Epoxy encapsulated construction.
- Low cost.
- Dielectric test voltage: 1500 Vrms.
- Dissipation rating: 150 mW.
- Peak pulse voltage: 100 Volts.
- Operating temperature: -20°C to +105°C.
- Custom designs available.

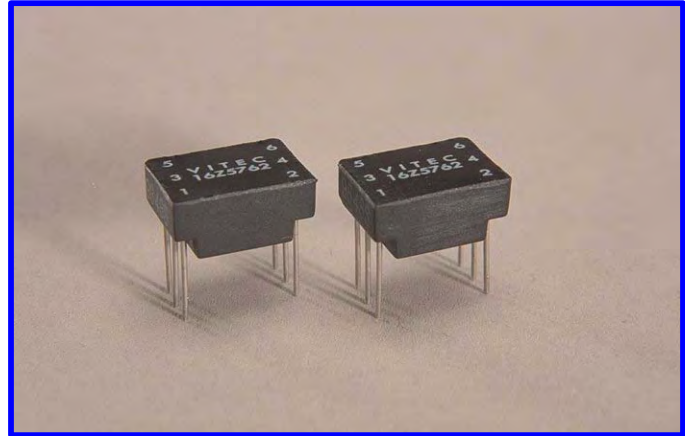

PACKAGE

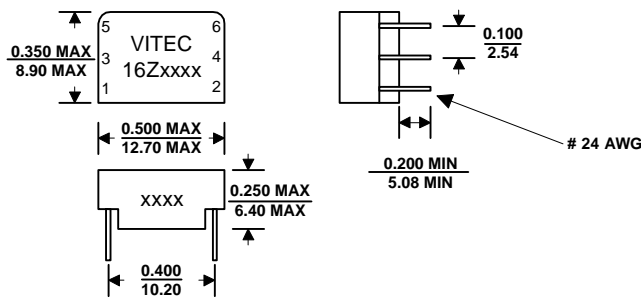

Dimensions Inches/mm +/- 0.01" Unless noted

SCHEMATIC A

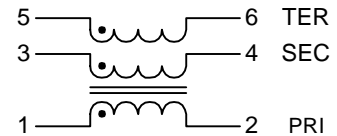

SCHEMATIC B

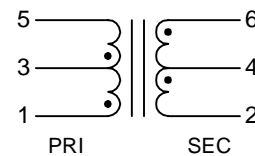

ELECTRICAL CHARACTERISTICS @ 25°C

Part Number	Turns Ratio	LP	ET Constant	Rise Time	Pri/Sec CC	Pri/Sec LL	Pri DCR	Sec DCR	Ter DCR	Schematic								
											mH	VmS	nS	pF	mH	Ohm	Ohm	Ohm
											MIN	MIN	MAX	MAX	MAX	MAX	MAX	MAX
16Z5760	1:1:1	5000	25.0	10.5	60	1.3	3.9	3.9	3.9	A								
16Z5761	1:1:1	2000	16.0	8.2	37	0.8	2.5	2.5	2.5	A								
16Z5762	1:1:1	500	8.5	5.3	32	0.4	1.3	1.3	1.3	A								
16Z5763	1:1:1	200	5.0	4.2	18	0.3	0.9	0.9	0.9	A								
16Z5764	1:1:1	50	5.2	5.6	18	0.5	1.3	1.3	1.3	A								
16Z5767	2:1:1	5000	25.0	16.0	33	3.6	3.9	2.0	2.0	A								
16Z5768	2:1:1	2000	16.0	11.0	19	1.8	2.5	1.4	1.4	A								
16Z5769	2:1:1	500	8.5	5.6	11	1.1	1.3	0.7	0.7	A								
16Z8270	1:1	2000	16.0	8.2	37	0.8	2.5	2.5	--	B								
16Z8271	1:1	500	8.5	5.3	32	0.4	1.3	1.3	--	B								
16Z8272	1:1	200	5.0	4.2	18	0.3	0.9	0.9	--	B								
16Z8276	2:1	2000	16.0	11.0	19	1.80	2.5	1.4	--	B								
16Z8277	2:1	500	8.5	5.6	12	1.2	1.4	0.80	--	B								
16Z8278	2:1	200	5.0	3.2	8	0.8	0.9	0.5	--	B								

TYPE 26Z - SMD PULSE TRANSFORMERS

General Purpose Applications

FEATURES

- Wide range of inductances for a variety of circuit applications.
- SMD package for pick and place manufacturing.
- Designed for vapor phase and IR reflow soldering.
- Low cost.



PACKAGE

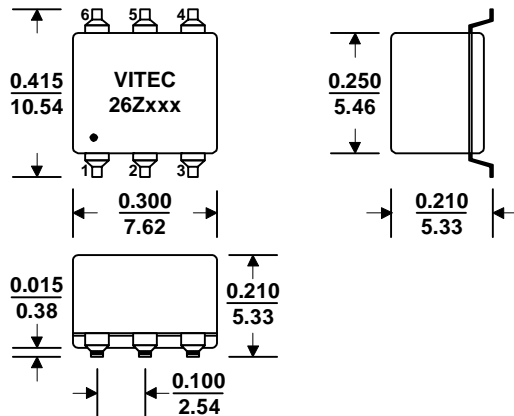

Drawing NOT to scale. Dimensions Inches/mm +/- 0.01" Unless noted

SCHEMATIC A

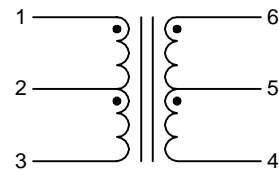

SCHEMATIC B

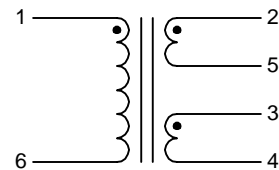

ELECTRICAL CHARACTERISTICS @ 25°C

Part Number	Turns Ratio +/- 5%	LP mH MIN	ET Constant VuS MIN	Rise Time nS MAX	Pri/Sec CC pF MAX	Pri/Sec LL uH MAX	Pri DCR Ohms MAX	Sec DCR Ohms MAX	Ter DCR Ohms MAX	Dielectric Test Vrms MIN	Schem.							
												MIN	MIN	MAX	MAX	MAX	MAX	MAX
26Z112	1:1:1	0.5	5.0	4.2	25	0.30	0.9	0.9	0.9	1500	B							
26Z113	1:1:1	0.2	4.0	3.5	18	0.20	0.7	0.7	0.7	1500	B							
26Z114	1:1:1	0.05	3.0	2.5	14	0.20	0.5	0.5	0.5	1500	B							
26Z119	2:1:1	0.5	5.0	4.2	18	0.30	0.9	0.45	0.45	1500	B							
26Z121	1CT:1CT	0.5	5.0	4.2	18	0.30	0.9	0.9	--	1500	A							
26Z122	1CT:1CT	0.2	4.0	3.5	14	0.20	0.7	0.7	--	1500	A							
26Z127	2CT:1CT	0.5	5.0	6.0	18	0.70	0.9	0.45	--	1500	A							
26Z271	1CT:1CT	0.5	8.5	--	32	0.4	1.3	1.3	--	1500	A							

Note: RoHS compliant version is not offered for this product series

LOW PROFILE SMD & DIP TRANSFORMERS

For DC/DC Converters

FEATURES

- Designed for isolation and voltage outputs in DC/DC converter circuits.
- Standard 6 pin SMD or DIP packages.
- Efficient toroidal design with excellent EMI suppression.
- Low cost.
- RoHS compliant version available

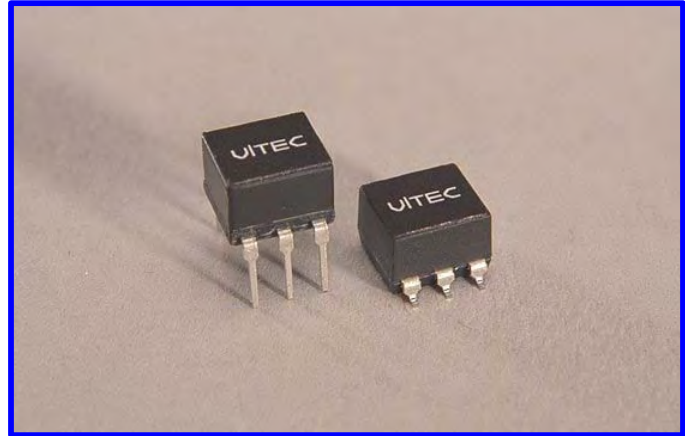

PACKAGE - SMD

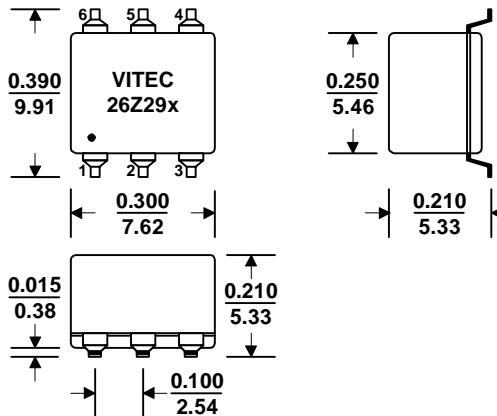

PACKAGE - DIP

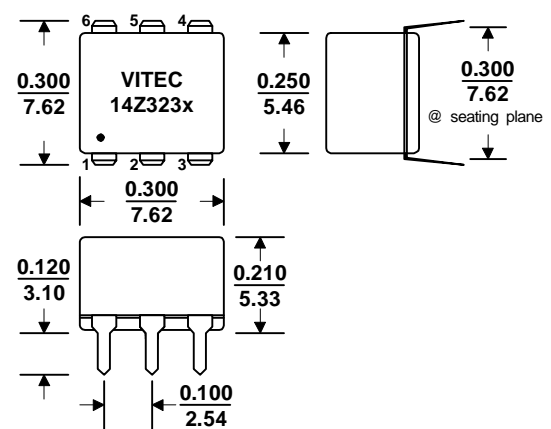

SCHEMATIC

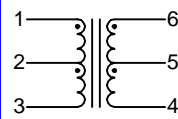

Drawing NOT to scale. Dimensions Inches/mm +/- 0.01" Unless noted

ELECTRICAL CHARACTERISTICS @ 25°C

Part Number				OCL	Turns Ratio	Insulation Resistance	ET Constant	Dissipation Rating	DCR Pri/Sec	Dielectric Test
SMD		DIP		uH	Ratio	MOhms	V-uS	mW	Ohm	Vrms
Classic	RoHS	Classic	RoHS	NOM	PRI SEC	MIN	MIN	MAX	MAX	MIN
26Z291	26ZR291	14Z3231	14ZR3231	1500	2CT:1CT	10,000	16	300	0.80/0.30	2000
26Z292	26ZR292	14Z3232	14ZR3232	1500	8CT:3CT	10,000	16	300	0.80/0.30	2000
26Z293	26ZR293	14Z3233	14ZR3233	1500	4CT:3CT	10,000	16	300	0.80/0.60	2000
26Z294	26ZR294	14Z3234	14ZR3234	1500	3CT:4CT	10,000	16	300	0.80/0.90	2000

Add an "R" to the part number after "Z" for the RoHS compliant version (i.e. 26ZR291 is the RoHS compliant version of 26Z291).

TRANSFORMER SELECTION GUIDE

For common LAN transceiver chips

ETHERNET, 10 BASE-T PRODUCTS

IC Manufacturer	IC P/N	Comments	AUI		10Base-T		Xfmr with Choke
			THT	SMD	THT	SMD	
AMD	Am7996/7	AUI	14Z4502	46Z302	-	-	
	Am79C series	AUI	14Z4502	46Z302	-	-	
Crystal	CS83C92	AUI	14Z4503	46Z303	-	-	
Fujitsu	MLB8392	AUI	14Z4503	46Z303	-	-	
Level One	LXT 901, 907	AUI, 10BaseT	14Z4502	46Z302	14Z3248	46Z248	46Z348
	LXT 902	AUI, 10BaseT	14Z4502	46Z302	14Z4507	46Z307	
	LXT 905	10BaseT	-	-	14Z3288	46Z288	
	LXT 914	AUI,Quad 10BT rcv	14Z4502	46Z302	14Z3227	46Z480	
	LXT 914	AUI,Quad 10BT xmt	14Z4502	46Z302	14Z3228	46Z481	
	LXT 944	AUI, 10BaseT	-	-	TBA	TBA	
National Semi	DP8391	AUI	14Z4503	46Z303	-	-	
	DP8392	AUI	14Z4503	46Z303	-	-	
Seeq	83C92	AUI	14Z4503	46Z303	-	-	
Signetics	NE83(Q)92	AUI	14Z4502	46Z302	-	-	
SSI	78Q902	AUI	14Z4502	46Z302	-	-	
	78Q8392	AUI	14Z4502	46Z302	-	-	

Common mode chokes also available: 24Z4687 (Through Hole) and 26Z085 (Surface Mount). These 4 wire chokes have individual cores for transmit and receive to minimize cross talk.

FAST ETHERNET: 10/100 AND 100BASE-T, 155 MBIT ATM PRODUCTS

IC Manufacturer	IC P/N	Comments	10/100 BASE-TX	100 BASE-TX
			SMD xfmr, choke	SMD xfmr, choke
Micro Linear	ML6692	Receive	46Z284	46Z284
	ML6692	Transmit	46Z285	46Z285
National Semi	DP83223	xmt/rcv 1:1	46Z282	46Z282
	DP83223	xmt/rcv 1:1.41	46Z283	46Z283
	DP83223	xmr/rcv 1:1 w/shunt	46Z333	46Z333

TYPE 46Z - SMD ISOLATION TRANSFORMERS

Ethernet/10Base-T

FEATURES

- Designed to meet or exceed IEEE 802.3.
- High isolation voltage to comply with international safety requirement for LAN.
- SMD packages for pick and place manufacturing.
- Designed for vapor phase and IR reflow soldering.
- Common mode choke available.

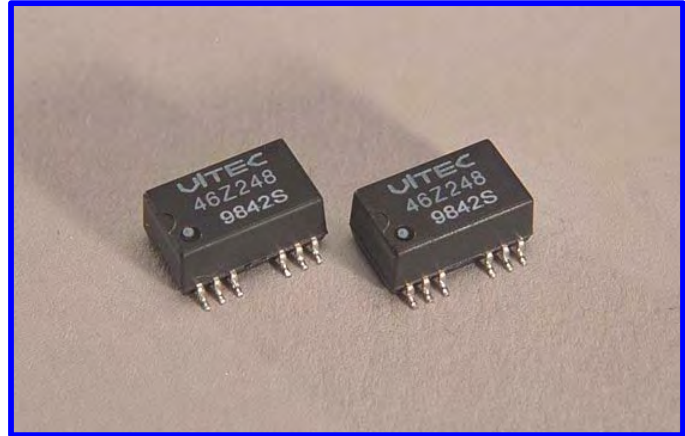

PACKAGE

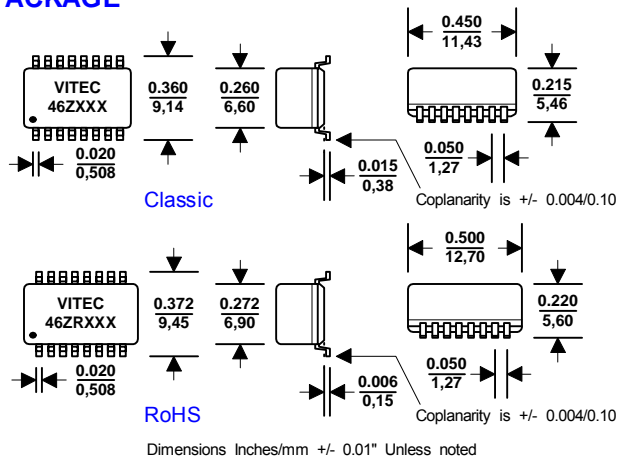

SCHEMATIC

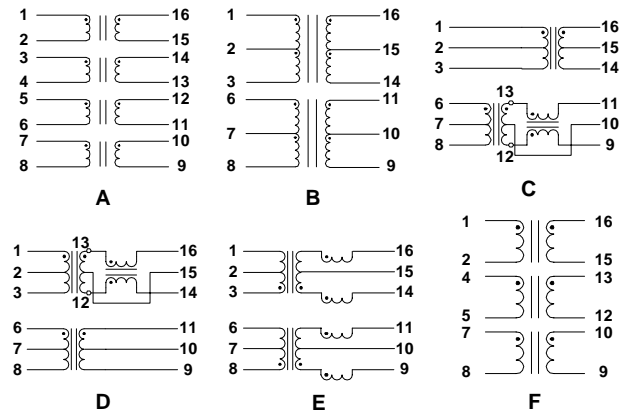

ELECTRICAL CHARACTERISTICS @ 25°C

Part Number		Turns Ratio		LP	Pri/Sec CC	LL	DCR	Dielectric Test	Primary Pins	Schem.
		+/- 5%								
Classic	RoHS	Transmit	Receive	uH MIN	pF MAX	uH MAX	Ohms MAX	Vrms MIN		
46Z205	46ZR205	2CT:1CT	1CT:1CT	100	10	0.40	0.50	2000	1-3/6-8	B
46Z248	46ZR248	1CT:1.41CT	1CT:1CT	200 *	15	0.50	0.40	2000	6-8/1-3	B
46Z288	46ZR288	1CT:2CT	1CT:1CT	200 *	10	0.30	0.30	2000	6-8/1-3	B
46Z301	TBD	1:1, 3 coils		40	8	0.20	0.25	2000	1-2/4-5/7-8	F
46Z302	TBD	1:1, 3 coils		75 *	10	0.20	0.20	2000	1-2/4-5/7-8	F
46Z303	TBD	1:1, 3 coils		100 *	10	0.20	0.30	2000	6-8/1-3	F
46Z304	TBD	1:1, 3 coils		150 *	12	0.20	0.30	2000	1-2/4-5/7-8	F
46Z307	TBD	1CT:1CT	1CT:1CT	200	12	0.30	0.30	2000	1-3/6-8	B
46Z308	TBD	1:1, 3 coils		350	16	0.30	0.35	2000	1-2/4-5/7-8	F
46Z343	TBD	1CT:2CT	1CT:1CT	200	12	0.30	1.00	2000	1-3/6-8	D
46Z347	TBD	1CT:1CT	1CT:1CT	200	10	0.25	1.00	1500	1-3/6-8	D
46Z348	46ZR348	1CT:1.41CT	1CT:1CT	200	12	0.50	0.60	2000	6-8/1-3	E
46Z349	TBD	1CT:2CT	1CT:1CT	140 **	12	0.10	0.60	2000	6-8/1-3	E
46Z352	TBD	2CT:1CT	1CT:1CT	140	12	0.30	1.00	1500	1-3/6-8	E
46Z388	TBD	1CT:2CT	1CT:1CT	200	10	0.30	0.50	2000	6-8/1-3	C
46Z480	TBD	--	1:1 (4X)	140	12	0.20	0.40	2000	1-2/3-4	A
46Z481	TBD	1:1.41, (4X)	--	140	12	0.20	0.40	2000	1-2/3-4,5-6/7-8	A

Notes: * Lp reading tolerance is +/-30%
** Tested on pin 1-3.

TYPE 14Z - DIP ISOLATION TRANSFORMERS

Ethernet/10Base-T

FEATURES

- Designed to meet or exceed IEEE 802.3.
- High isolation voltage to comply with international safety requirements for LAN.
- Low profile auto-insertable package.
- Low cost.
- Common mode chokes available.
- SMD package available.

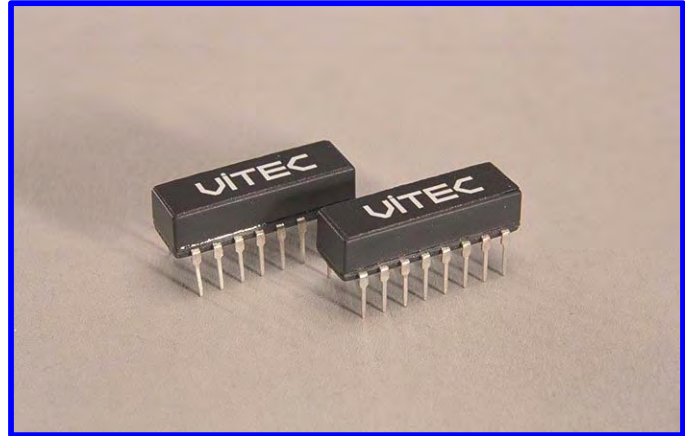

PACKAGE

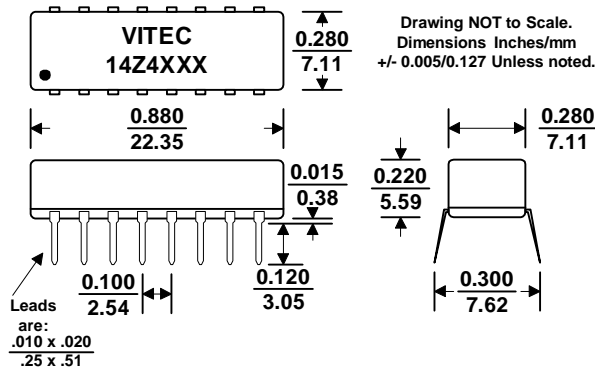

SCHEMATIC A

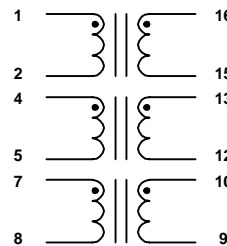

SCHEMATIC B

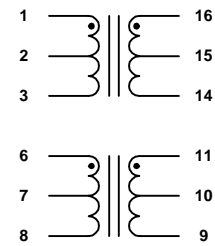

ELECTRICAL CHARACTERISTICS @ 25°C

Part Number	Turns Ratio		LP	Pri/Sec Cc	Pri/Sec LL	Pri DCR	Dielectric Test	Rise Time	ET Constant	Primary Pins	Schematic							
	+/- 5%											uH	pF	uH	Ohms	Vrms	ns	V-us
	Transmit	Receive																
14Z3225	2CT:1CT	1CT:1CT	80	10	0.4	0.5	2000	--	2.1	1-3/6-8	B							
14Z3248	1CT:1.41CT	1CT:1CT	140	15	0.5	0.4	2000	--	2.1	6-8/1-3	B							
14Z3288	1CT:2CT	1CT:1CT	200	10	0.3	0.3	2000	--	2.1	6-8/1-3	B							
14Z4102	1:1, 3 coils		75	10	0.2	0.2	500	3.0	2.1	1-2/4-5/7-8	A							
14Z4103	1:1, 3 coils		100	10	0.2	0.3	500	3.0	2.1	1-2/4-5/7-8	A							
14Z4104	1:1, 3 coils		150	12	0.2	0.3	500	3.5	2.1	1-2/4-5/7-8	A							
14Z4502	1:1, 3 coils		75	10	0.2	0.2	2000	3.0	2.1	1-2/4-5/7-8	A							
14Z4503	1:1, 3 coils		100	10	0.2	0.3	2000	3.0	2.1	1-2/4-5/7-8	A							
14Z4507	1CT:1CT	1CT:1CT	200	15	0.25	0.3	2000	--	2.1	1-3/6-8	B							

TYPE 24Z - DIL ISOLATION TRANSFORMERS

Ethernet/10Base-T

FEATURES

- Designed to meet or exceed IEEE 802.3.
- High isolation voltage to comply with international safety requirements for LAN.
- Low profile Epoxy encapsulated construction.
- Meets UL 1950.
- Low cost.
- Common mode chokes available.

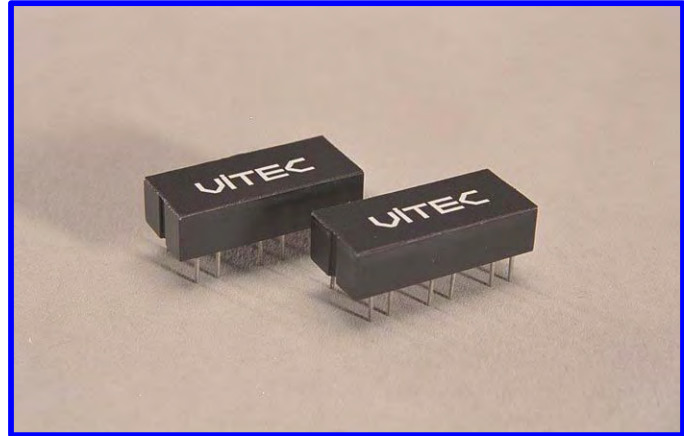

PACKAGE 1

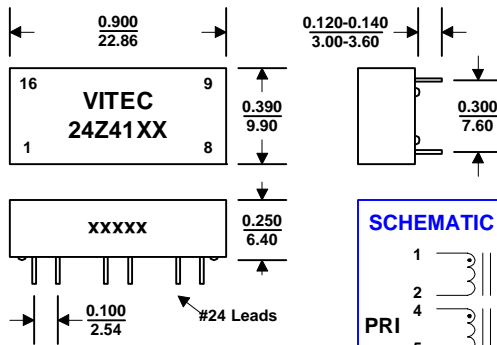

SCHEMATIC

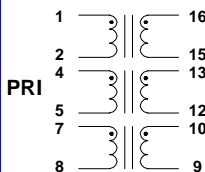

Dimensions Inches/mm +/- 0.01" Unless noted

PACKAGE 2

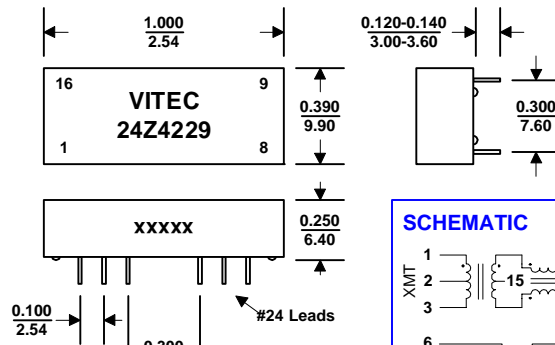

SCHEMATIC

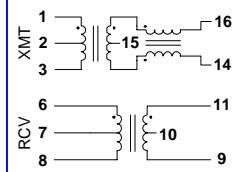

Dimensions Inches/mm +/- 0.01" Unless noted

ELECTRICAL CHARACTERISTICS @ 25°C

Part Number	Turns Ratio	LP	Pri/Sec Cc	Pri/Sec LL	Pri DCR	Dielectric Test	Rise Time	ET Constant	Package
			pF	uH	Ohms				
		MIN	MAX	MAX	MAX	MAX	MAX	MIN	
24Z4105	1:1	35	8	0.25	0.3	2000	3.5	1.8	1
24Z4106	1:1	50	9	0.25	0.3	2000	3.5	2.2	1
24Z4107	1:1	75	10	0.25	0.3	2000	3.5	2.4	1
24Z4108	1:1	100	10	0.25	0.4	2000	3.5	2.5	1
24Z4109	1:1	150	12	0.25	0.5	2000	3.5	3.0	1
24Z4229	Turns Ratio	LP		Pri/Sec Cc	Pri/Sec LL	Pri DCR	Sec DCR	Package	
		uH		pF	uH				Ohm
	+/- 2%		MIN		MAX	MAX	MAX	MAX	
	XMT	RCV	XMT	RCV	12	0.30	XMT	RCV	2000
1CT:2CT	1CT:1CT	50	200			0.35	0.50		

TYPE 40Z - SMD TRANSFORMER MODULES

Quad Port 10Base-T

FEATURES

- Designed for Multi-port repeater and Switched Ethernet applications.
- Designed to meet requirements of IEEE 802.3.
- Product matched to most IC manufacturer.
- 40 Pin low profile SMD package for Pick and Place manufacturing.
- Common footprints & pinouts with multiple filtering options for customized EMI performance.

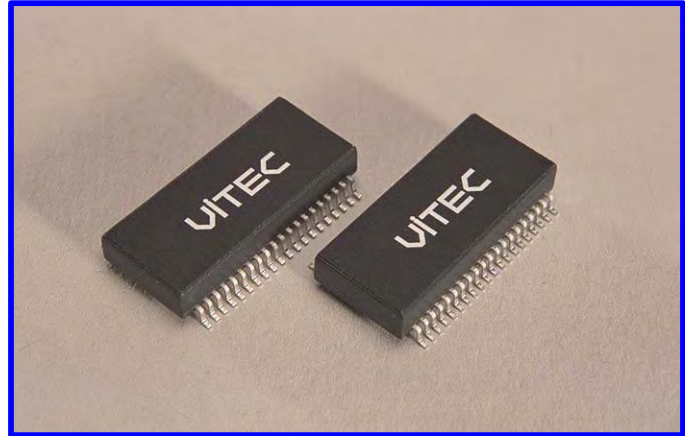

PACKAGE

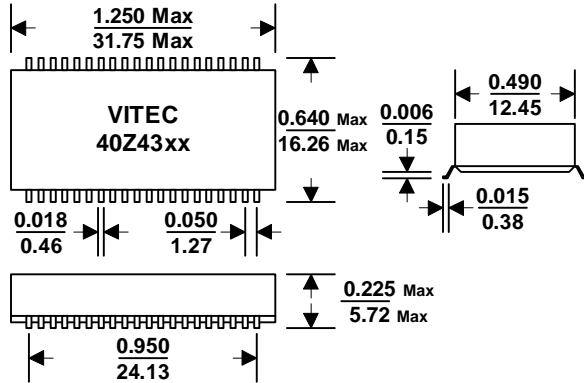

Drawing NOT to Scale. Dimensions Inches/mm +/- 0.005/0.127 Unless noted.

SCHEMATIC A

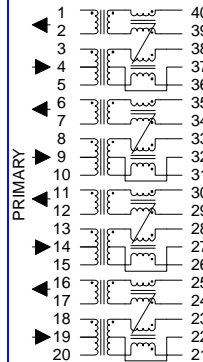

SCHEMATIC B

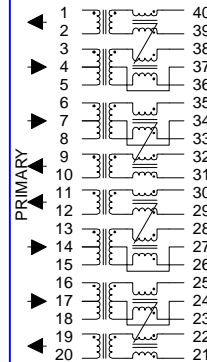

SCHEMATIC C

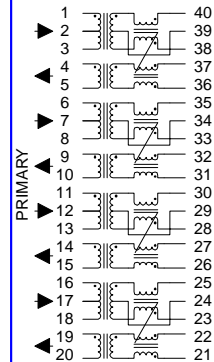

ELECTRICAL CHARACTERISTICS @ 25°C

Part Number	Turns Ratio		Xmt/Rcv LP	Pri/Sec Cc	Xmt/Rcv Pri LL	Xmt/Rcv Pri DCR	Optional CMR Choke	CMC Inductance	Dielectric Test	Insulation Resistance	Schem.
	XMT	RCV									
	+/- 3%	+/- 3%									
40Z4350	1CT:1	1:1	100/100	12	0.30/0.30	0.30/0.30	N/A	--	1500	10000	A
40Z4351	1CT:1CT	1:1	100/100	12	0.30/0.30	0.30/0.30	Xmt	36	1500	10000	A
40Z4360	1CT:1.41CT	1:1	140/140	12	0.40/0.40	0.40/0.40	Xmt/Rcv	36	1500	10000	C
40Z4361	1CT:1CT	1:1	100/100	12	0.30/0.30	0.30/0.30	Xmt/Rcv	36	1500	10000	C
40Z4362	1CT:2CT	1:1	50/200	12	0.30/0.30	0.35/0.50	Xmt/Rcv	36	1500	10000	C
40Z4363	1CT:1.41CT	1:1	140/140	12	0.40/0.40	0.40/0.40	Xmt/Rcv	36	1500	10000	A
40Z4364	1CT:1CT	1:1	100/100	12	0.30/0.30	0.30/0.30	Xmt/Rcv	36	1500	10000	A
40Z4365	1CT:2CT	1:1	50/200	12	0.30/0.30	0.35/0.50	Xmt/Rcv	36	1500	10000	A
40Z4366	1CT:1.41CT	1:1	140/140	12	0.40/0.40	0.40/0.40	Xmt/Rcv	36	1500	10000	B
40Z4367	1CT:1CT	1:1	100/100	12	0.30/0.30	0.30/0.30	Xmt/Rcv	36	1500	10000	B
40Z4368	1CT:2CT	1:1	50/200	12	0.30/0.30	0.35/0.50	Xmt/Rcv	36	1500	10000	B
40Z4370	1CT:1.41CT	1:1	140/140	12	0.40/0.40	0.40/0.40	Xmt	36	1500	10000	C
40Z4371	1CT:1CT	1:1	100/100	12	0.30/0.30	0.30/0.30	Xmt	36	1500	10000	C
40Z4372	1CT:2CT	1:1	50/200	12	0.30/0.30	0.35/0.50	Xmt	36	1500	10000	C
40Z4390	1CT:1.41CT	1:1	140/140	12	0.40/0.40	0.40/0.40	N/A	--	1500	10000	C
40Z4391	1CT:1	1:1	100/100	12	0.30/0.30	0.30/0.30	N/A	--	1500	10000	C
40Z4392	1CT:2	1:1	50/200	12	0.30/0.30	0.35/0.50	N/A	--	1500	10000	C

Notes:

TYPE 40Z - SMD TRANSFORMER MODULES

Dual Port 10/100 Base-Tx

FEATURES

- Products matched to most IC manufacturers.
- Designed to meet insertion loss and return loss requirements of IEEE 802.3u.
- 40 Pin low profile SMD package for Pick and Place manufacturing.
- Common footprints & pinouts.

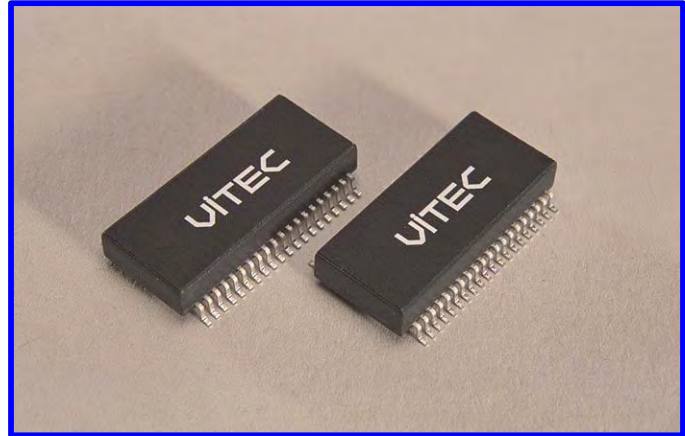

PACKAGE

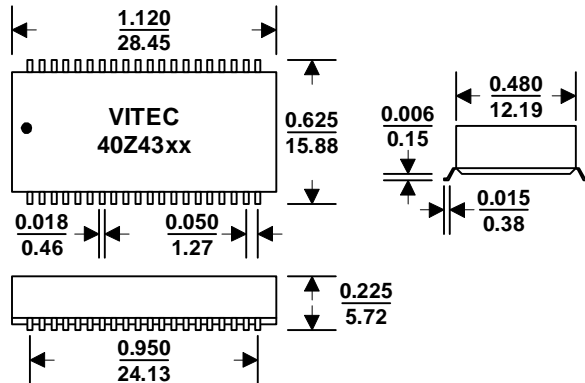

Drawing NOT to Scale. Dimensions Inches/mm +/- 0.005/0.127 Unless noted.

SCHEMATIC A

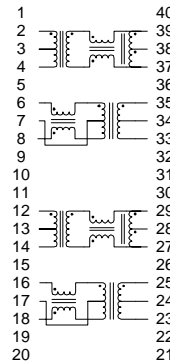

SCHEMATIC B

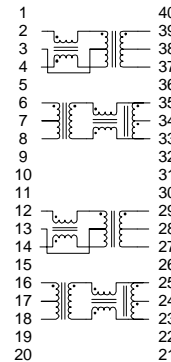

SCHEMATIC C

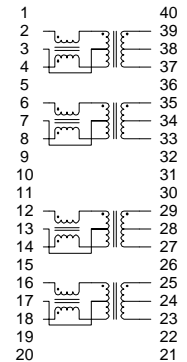

ELECTRICAL CHARACTERISTICS @ 25°C

Part Number	Turns Ratio		LP	Cross Talk	CMR	Circuit Position	Rise Time	LL	Cc	DCR	Dielectric Test	Schem.
	XMT	RCV					nS	uH	pF	Ohms	Vrms	
	+/- 5%	+/- 5%					TYP	MAX	TYP	MAX	MIN	
40Z4340	1CT:1CT	1CT:1CT	350	-38	-40	Rx-Tx, Rx-Tx	2.5	0.4	20	0.9	1500	B
40Z4341	1CT:1CT	1CT:1CT	350	-38	-40	Tx-Rx, Tx-Rx	2.5	0.4	20	0.9	1500	A
40Z4342	2CT:1CT	1CT:1CT	350	-38	-40	Rx-Tx, Rx-Tx	2.5	0.4	20	0.9	1500	B
40Z4343	2CT:1CT	1CT:1CT	350	-38	-40	Tx-Rx, Tx-Rx	2.5	0.4	20	0.9	1500	A
40Z4344	1.25CT:1CT	1CT:1CT	350	-38	-40	Rx-Tx, Rx-Tx	2.5	0.4	20	0.9	1500	B
40Z4345	1.25CT:1CT	1CT:1CT	350	-38	-40	Tx-Rx, Tx-Rx	2.5	0.4	20	0.9	1500	A
40Z4346	1CT:1.41CT	1CT:1CT	350	-38	-40	Rx-Tx, Rx-Tx	2.5	0.4	20	0.9	1500	B
40Z4347	1CT:1.41CT	1CT:1CT	350	-38	-40	Tx-Rx, Tx-Rx	2.5	0.4	20	0.9	1500	A
40Z4348	1.41CT:1CT	1CT:1CT	350	-38	-40	Tx-Rx, Tx-Rx	2.5	0.4	20	0.9	1500	C
40Z4349	1.25CT:1CT	1CT:1CT	350	-38	-40	Tx-Rx, Tx-Rx	2.5	0.4	20	0.9	1500	C

Notes:

TYPE 46Z - SMD TRANSFORMER MODULES

10/100 Base-TX

FEATURES

- Designed to meet or exceed IEEE 802.3 for 10/100-TX and ATM 155 applications.
- High isolation voltage to comply with international safety requirement for LAN.
- SMD packages for pick and place manufacturing.
- Designed for vapor phase and IR reflow soldering.
- Return Loss
 (0.5-30MHz): -18.0 dB MIN
 (40MHz): -15.5 dB MIN
 (50MHz): -13.6 dB MIN
 (60-80MHz): -12.0 dB MIN

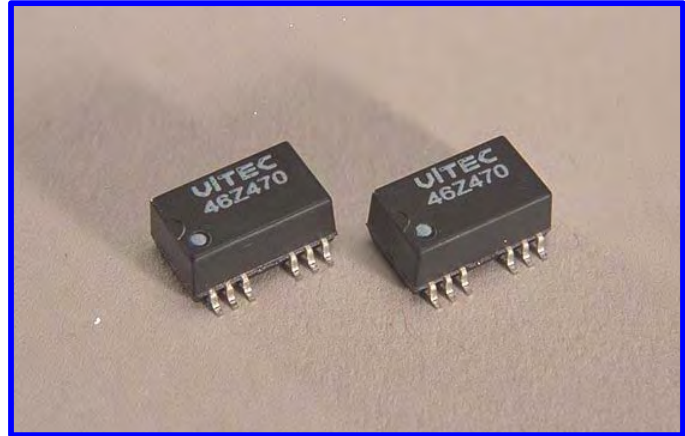

PACKAGE

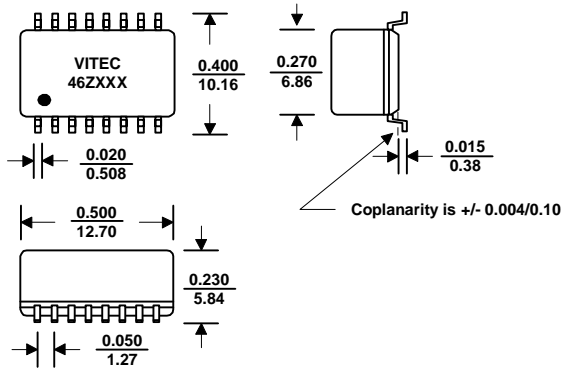

Dimensions Inches/mm +/- 0.01* Unless noted

SCHEMATIC A

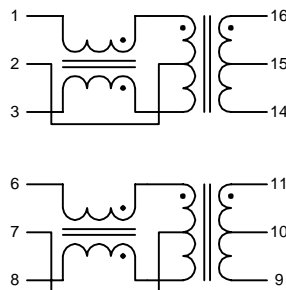

SCHEMATIC B

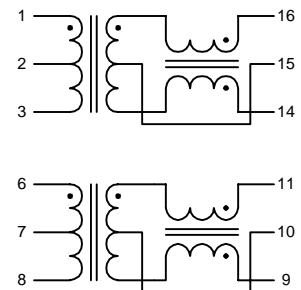

ELECTRICAL CHARACTERISTICS @ 25°C

Part Number		Turns Ratio	Lp**	Pri/Sec Cc	Pri LL	Pri DCR	Pri LL	CMR*	Crosstalk*	Insertion Loss*	Dielectric Test	Schematic
		+/- 3%	uH	pF	uH	Ohm	uH	dB	dB	dB	Vrms	
Classic	RoHS	(1-3:16-14)/(6-8:11-9)	MIN	NOM	MAX	MAX	MAX	NOM	MIN	MAX	MIN	
46Z470	46ZR470	1CT:1CT/1CT:1CT	350	15	0.40	0.90	0.40	-40	-40	-1.10	1500	A
46Z471	Call Factory	2CT:1CT/1CT:1CT	350	15	1.20	0.90	1.20	-40	-40	-1.10	1500	B
46Z472	Call Factory	1CT:1CT/2CT:1CT	350	15	1.20	0.90	1.20	-40	-40	-1.10	1500	B
46Z473	Call Factory	1.41CT:1CT/1CT:1CT	350	15	0.90	0.90	0.90	-40	-40	-1.10	1500	B
46Z474	Call Factory	1.25CT:1CT/1CT:1CT	350	15	0.90	0.90	0.90	-40	-40	-1.10	1500	B
46Z475	46ZR475	1CT:1.41CT/1CT:1CT	350	15	0.40	0.90	0.40	-40	-40	-1.10	1500	B

Notes: * Tested @ 0.1-100 MHz.
 ** @ 8mA DC, 0 - 70 degrees C.

TYPE 34Z - SMD TRANSFORMER MODULES

High Speed LAN

FEATURES

- Designed for 10/100, 100 and 155 Mbps transmission over UTP and STP cable.
- Meet IEEE 802.3u and ANSI x3.236-1995 standard.
- Surface mount package for pick and place. Special configuration available for most IC manufacturers.
- Rise time: 2.50 nS TYP
- Cross talk: -38dB MIN (0-1-100MHz)
Dielectric test voltage: 1500 Vrms MIN



PACKAGE

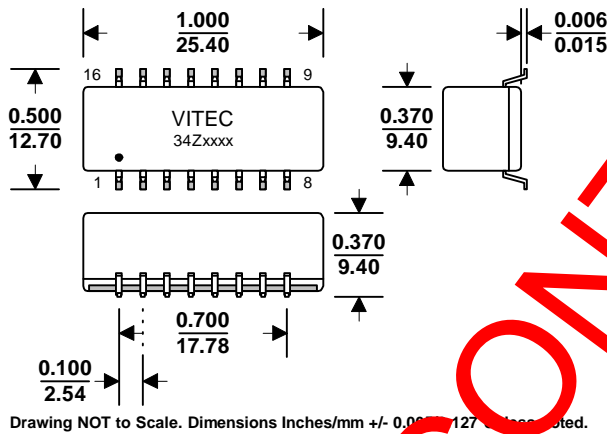

SCHEMATIC A

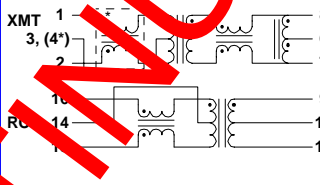

SCHEMATIC C

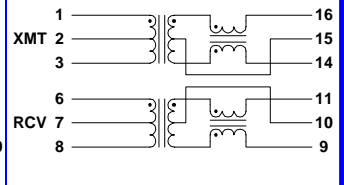

SCHEMATIC B

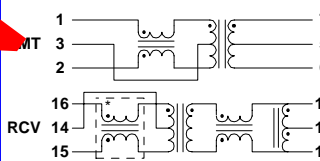

SCHEMATIC D

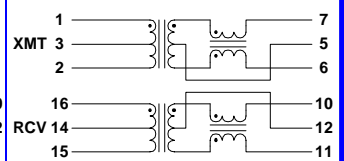

ELECTRICAL CHARACTERISTICS @ 25°C

Part Number	Turns Ratio		L	LL	Cc	DCR	CMR	Insert. Loss	Return Loss			Schem.
	XMT	RCV							MIN	MAX	MAX	
34Z2202	1CT:1CT	1CT:1CT	350	0.40	15	0.90	-45	-1.10	-15.50	-13.60	-12.00	A*
34Z2203	1CT:1CT	1CT:1CT	350	0.40	18	0.90	-40	-1.10	-15.50	-13.60	-12.00	B
34Z2204	1CT:1CT	1CT:1CT	350	0.40	15	0.90	-40	-1.10	-15.50	-13.60	-12.00	A
34Z2205	1CT:1CT	1CT:1CT	350	0.40	15	1.00	-45	-1.10	-15.50	-13.60	-12.00	B*
34Z2206	1.25CT:1CT	1CT:1CT	350	0.35	20	0.90	-40	--	--	--	--	C
34Z2207	1.41CT:1CT	1CT:1CT	350	0.40	20	0.90	-40	--	--	--	--	C
34Z2208	1.41CT:1CT	1CT:1CT	350	0.40	20	0.90	-40	--	--	--	--	D

TYPE 34Z - LOW PROFILE SMD TRANSFORMER MODULES

High Speed LAN

FEATURES

- Designed for 10/100, 100 and 155 Mbps transmission over UTP and STP cable.
- Meet IEEE 802.3u and ANSI x3.236-1995 Std.
- Surface mount package for pick and place.
- Special configuration available for most IC manufacturers.
- Rise time: 2.50 nS TYP
- Cross talk: -38dB MIN (0-1-100MHz)
- Dielectric test voltage: 1500 Vrms MIN
- 350 uH @ 8 mA DC, 0-70°C.

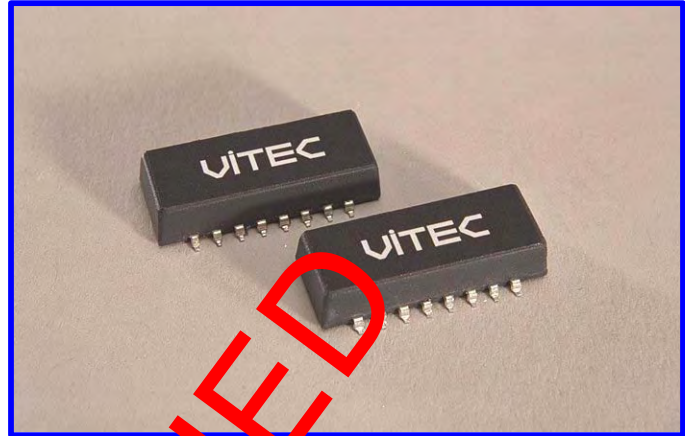

PACKAGE

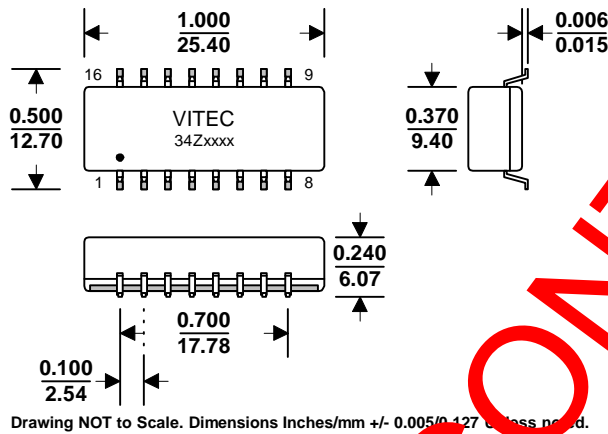

SCHEMATIC A

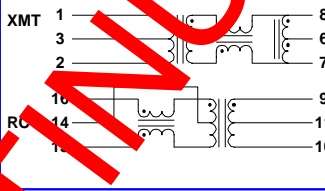

SCHEMATIC C

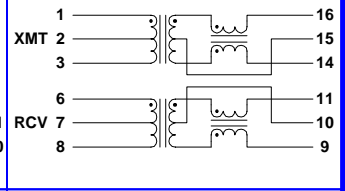

SCHEMATIC B

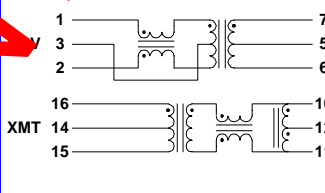

SCHEMATIC D

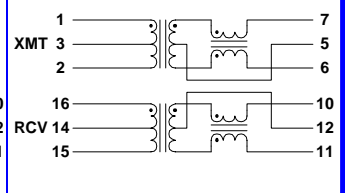

ELECTRICAL CHARACTERISTICS @ 25°C

Part Number	Turns Ratio		LP	LL	Cc	DCR	CMR	Insert. Loss	Return Loss			Schem.
	XMT	RCV	uH	uH	pF	Ohm	dB	dB	0.5-40MHz	50MHz	60-80MHz	
			MIN	MAX	MAX	TYP	MAX					
34Z2253	1CT:1CT	1CT:1CT	400	0.40	20	0.90	-40	-1.10	-15.50	-13.60	-12.00	B
34Z2254	1CT:1CT	1CT:1CT	400	0.40	15	0.90	-40	-1.10	-15.50	-13.60	-12.00	A
34Z2256	1.25CT:1CT	1CT:1CT	400	0.35	20	0.90	-40	--	--	--	--	C
34Z2257	1.41CT:1CT	1CT:1CT	400	0.40	20	0.90	-40	--	--	--	--	C
34Z2258	1.41CT:1CT	1CT:1CT	400	0.40	20	0.90	-40	--	--	--	--	D

TRANSFORMER SELECTION GUIDE

For T1/E1 Interface

IC Manufacturer & IC P/N	Comments	Dual SMD		Single THT				Dual THT		Reinforced	
		Std Temp	Ext Temp	Std Temp		Ext Temp		Std Temp	Ext Temp	3000 Vrms	
		Xmt & Rcv	Xmt & Rcv	Transmit	Receive	Transmit	Receive	Xmt & Rcv	Xmt & Rcv	Transmit	Receive
AT&T											
T7288	CEPT	46Z216	28Z627	16Z5935	16Z5950	16Z5981	16Z5983	24Z4652	24Z4672	18Z4882	18Z4885
T7289	DS1	46Z217	28Z628	16Z5949	16Z5946	16Z5982	16Z5983	24Z4665	24Z4670	18Z4883	18Z4885
T7290	T1 & CEPT	46Z216	28Z627	16Z5935	16Z5950	16Z5981	16Z5983	24Z4652	24Z4672	18Z4877	18Z4885
T7290	DS1	---	---	---	16Z5950	---	16Z5983	---	---	---	---
T7690	DS1	46Z230	28Z632	---	---	---	---	---	---	18Z4883	18Z4883
T7690	CEPT	---	28Z635	16Z5935	16Z5935	16Z5981	---	---	---	18Z4882	18Z4882
Brooktree											
BT8370	---	---	---	16Z5952	16Z5950	---	---	24Z4665	---	---	---
BT8370	---	---	---	16Z5935	16Z5950	---	---	24Z4652	---	---	---
UGA 510-1	---	46Z232	28Z654	16Z5934	16Z5946	16Z5984	16Z5983	24Z4654	---	18Z4884	18Z4885
R8069, R8069A, R8069B	---	46Z232	28Z654	---	16Z5934	---	---	24Z4654	---	---	18Z4884
Crystal											
61534, 61544, 61574, 6158, 61535	T1 & PCM30	46Z215	28Z626	16Z5946	16Z5946	16Z5983	16Z5983	24Z4651	---	18Z4885	18Z4885
61535A, 61574A, 61575, 6158A	T1	46Z217	28Z628	16Z5952	16Z5946	16Z5982	16Z5983	24Z4665	24Z4670	18Z4883	18Z4885
61535A, 61574A, 61575, 6158A	PCM30, 75, 120	46Z218	28Z629	16Z5953	16Z5946	16Z5985	16Z5983	24Z4666	24Z4671	18Z4889	18Z4885
6152	---	46Z216	28Z627	16Z5935	16Z5946	16Z5981	16Z5983	24Z4652	24Z4672	18Z4882	18Z4885
61584	IQ3	46Z215	28Z626	16Z5946	16Z5946	16Z5983	16Z5983	24Z4653	---	18Z4885	18Z4885
61584	IQ5	46Z230	28Z632	16Z5952	16Z5952	16Z5982	16Z5982	---	---	18Z4883	18Z4883
Dallas											
DS2186, DS2187	---	46Z216	28Z627	16Z5935	16Z5946	16Z5981	16Z5983	24Z4652	24Z4672	18Z4882	18Z4885
DS2151, DS2153	T1, E1	46Z217	28Z634	16Z5952	16Z5936	16Z5982	16Z5984	24Z4665	24Z4670	18Z4883	18Z4884
DS2151, DS2153	Special Protect	---	---	16Z5925	16Z5924	---	---	---	---	---	---
Exar											
T5650, T5620, T5675, T5681, T5683	---	46Z215	28Z626	16Z5950	16Z5950	16Z5983	16Z5983	24Z4651	---	18Z4885	18Z4885
56L22, 56L85, C240, C260, C262, C277	---	46Z215	28Z626	16Z5950	16Z5950	16Z5983	16Z5983	24Z4651	---	18Z4885	18Z4885
T5791, T5793, T5794	---	46Z218	28Z629	16Z5953	16Z5934	16Z5985	16Z5984	---	---	18Z4889	18Z4884
T5684	---	46Z216	---	16Z5950	16Z5937	---	---	---	---	18Z4885	18Z4882
T7288	---	46Z216	28Z627	16Z5935	16Z5946	16Z5981	16Z5983	24Z4652	24Z4672	18Z4882	18Z4885
Level One											
LXT300, LXT301, LXT305	---	46Z215	28Z626	16Z5946	16Z5946	16Z5983	16Z5983	24Z4651	---	18Z4885	18Z4885
LXT300, LXT301, LXT305	Monitor	---	---	16Z5946	16Z5948	---	---	---	---	---	---
LXT304A, LXT305A	T1	46Z217	28Z628	16Z5952	16Z5946	16Z5982	16Z5983	24Z4665	24Z4670	18Z4883	18Z4885
LXT304A, LXT305A	PCM30, 75, 120	46Z218	28Z629	16Z5953	16Z5946	16Z5985	16Z5983	24Z4666	24Z4671	18Z4889	18Z4885
LXT304A, LXT305A	DSX1, D4	---	---	16Z5961	---	---	---	---	---	---	---
LXT310, LXT311	---	46Z232	28Z633	16Z5946	16Z5936	16Z5983	16Z5984	24Z4654	---	18Z4885	18Z4885
LXT312, LXT313, LXT315	---	---	---	---	16Z5932	---	16Z5984	---	24Z4673/4	18Z4886	18Z4885
LXT318, LXT319	---	46Z232	28Z633	16Z5946	16Z5936	16Z5983	16Z5984	24Z4654	---	18Z4890	18Z4889
LXT324, LXT325	DSX1	---	---	---	16Z5946	---	---	---	---	---	---
LXT324, LXT325	Monitor	---	---	---	16Z5948	---	---	---	---	---	---
LXT332	---	46Z215	28Z626	16Z5946	16Z5946	16Z5983	16Z5983	24Z4651	---	18Z4885	18Z4885
LXT332	T1	---	28Z637	---	---	---	---	---	---	---	---
PMC-Sierra											
PM4341, PM6341	---	46Z216	28Z627	16Z5937	16Z5946	16Z5981	16Z5983	24Z4652	24Z4672	18Z4882	18Z4885
Siemens											
PEB2235, PEB2235A1, PEB2235B	T1	---	---	16Z5942	16Z5942	---	---	24Z4657	---	---	---
PEB2235, PEB2235A1, PEB2235B	CEPT 75	---	---	16Z5940	16Z5940	---	---	24Z4655	---	18Z4880	18Z4880
PEB2235, PEB2235A1, PEB2235B	CEPT 120	---	28Z630	16Z5941	16Z5941	---	---	24Z4656	---	18Z4881	18Z4881
PEB2235B1, PEB2254	---	46Z231/29	28Z636	16Z5963	16Z5963	---	---	24Z4668	---	18Z4891	18Z4891
SSI											
78P300	T1 & E1	46Z215	28Z626	16Z5946	16Z5946	16Z5983	16Z5983	24Z4651	---	18Z4885	18Z4885
78P300	T1	46Z217	28Z628	16Z5952	16Z5946	16Z5982	16Z5983	24Z4665	24Z4670	18Z4883	18Z4885
VLSI											
VPI4Q574	T1	46Z217	28Z628	16Z5952	16Z5946	16Z5982	16Z5983	24Z4665	24Z4670	18Z4883	18Z4885
VPI4Q574	E1	46Z218	28Z629	16Z5953	16Z5946	16Z5985	16Z5983	24Z4666	24Z4671	18Z4889	18Z4885
VPI4Q575	T1	46Z217	28Z628	16Z5952	16Z5946	16Z5982	16Z5983	24Z4665	24Z4670	18Z4883	18Z4885
VPI4Q575	E1 75	46Z218	28Z629	16Z5953	16Z5946	16Z5985	16Z5983	24Z4666	24Z4671	18Z4889	18Z4885
VPI4Q575	E1 120	---	---	16Z5940	16Z5946	---	---	---	---	18Z4890	18Z4885

TYPE 46Z - SMD DUAL MINIATURE TRANSFORMERS

T1/CEPT/ISDN-PRI

FEATURES

- Designed to meet FCC and CCITT G.703.
- SMD packages for pick and place assembly.
- Designed for vapor phase and IR reflow soldering.
- Extended temperature (-40°C to +85°C) versions available, please call factory.

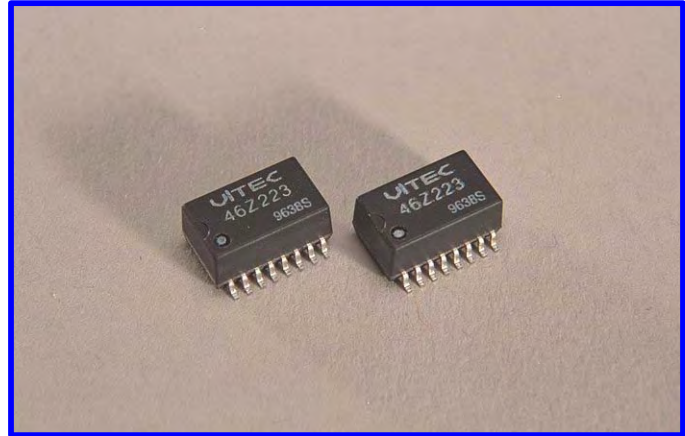

PACKAGE

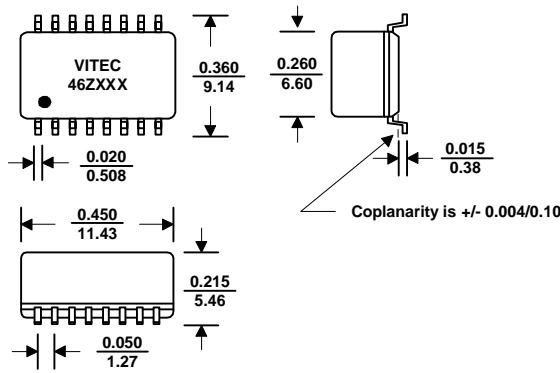

Dimensions Inches/mm +/- 0.01" Unless noted

SCHEMATIC

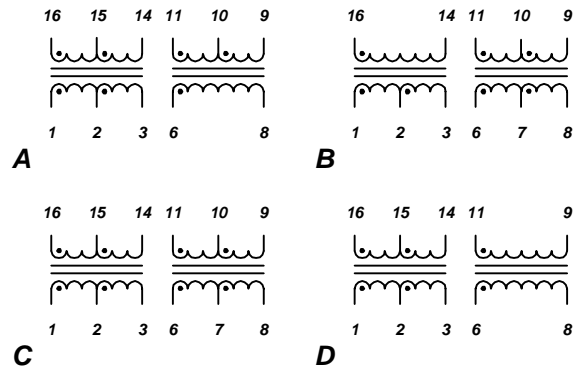

ELECTRICAL CHARACTERISTICS @ 25°C

Part Number	Turns Ratio	LP	Pri/Sec	Pri/Sec	Primary DCR	Secondary DCR	Schematic	Primary Pins
			LL	Cc				
			mH	pF				
	+/- 5%	MIN	MAX	MAX	Ohms	Ohms		
					MAX	MAX		
46Z214	1CT:2CT&1:1	1.20	0.55&0.50	30 & 30	0.70 & 1.10	0.70 & 0.70	D	1-3,11-9
46Z215	1CT:2CT&1CT:2CT	1.20	0.60	30 & 30	0.70 & 0.70	1.40 & 1.40	C	16-14,6-8
46Z216	1CT:2CT&1:1.36CT	1.20	0.50&0.80	30 & 30	0.70 & 0.70	1.00 & 0.80	A	16-14,6-8
46Z217	1:1.15CT&1CT:2CT	1.20	0.60&0.60	30 & 30	0.70 & 0.70	0.70 & 1.00	B	16-14,6-8
46Z218	1:1/1.26&1CT:2CT	1.20	0.60&0.60	30 & 30	0.70 & 0.70	0.80 & 1.10	B	16-14,6-8
46Z223	1CT:2.3CT&1CT:2CT	1.20	0.80	35 & 30	0.70 & 0.70	1.00 & 1.10	C	1-3,6-8
46Z224	1CT:1.53&1CT:2CT	1.20	0.80	35 & 30	0.70 & 0.70	1.00 & 0.90	C	1-3,6-8
46Z229	1CT:1.41CT&1CT:1.41CT	1.00	0.60	30 & 30	0.70 & 0.70	0.90 & 0.90	C	1-3,11-9
46Z230	1CT:1.15CT&1CT:1.15CT	1.20	0.60	30 & 30	0.70 & 0.70	0.75 & 0.75	C	1-3,6-8
46Z231	1CT:1.41CT&1CT:1.41CT	1.00	0.60	30 & 30	0.70 & 0.70	0.90 & 0.90	C	16-14,11-9
46Z232	1CT:1CT&1CT:2CT	1.20	0.60	30 & 30	0.70 & 0.70	0.70 & 1.00	C	16-14,6-8

TYPE 28Z - SMD TRANSFORMERS

T1/CEPT/ISDN-Pri Interface

FEATURES

- SMD package for pick and place assembly.
- Designed for vapor phase and IR reflow soldering.
- Designed to meet FCC and CCITT G.703.
- Meets UL1459 and UL1950.
- Available for both standard temperature and extended temperature applications.
- RoHS compliant version available.

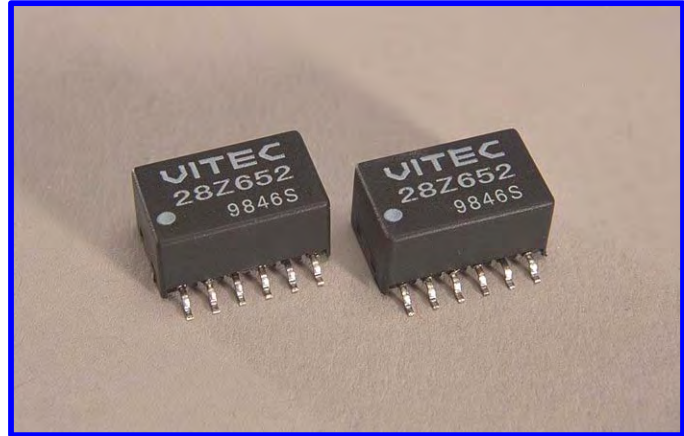

PACKAGE

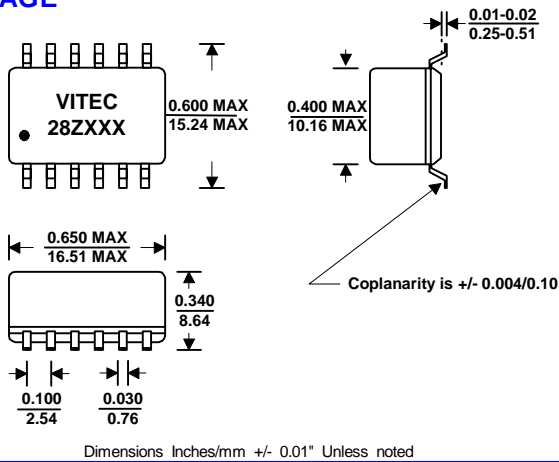

SCHEMATICS

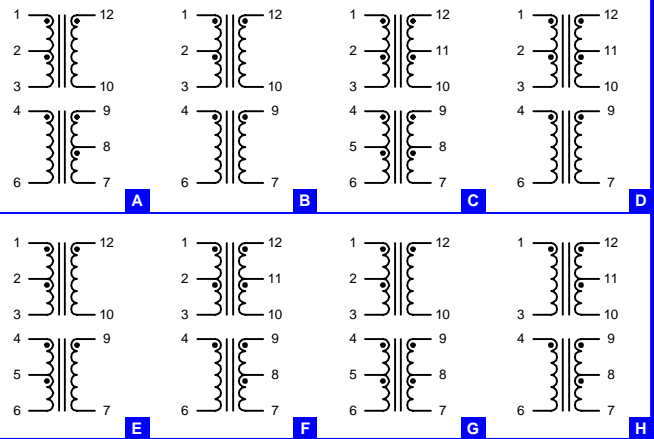

ELECTRICAL CHARACTERISTICS @ 25°C

Part Number		Turns Ratio	OCL	LL	CC	Pri DCR	Sec DCR	Schematic	Primary Pins
Classic	RoHS	Ratio +/- 5%	mH MIN	uH MAX	pF MAX	Ohms MAX	Ohms MAX		
Standard Temperature									
28Z651	28ZR651	1:2CT&1:2CT	1.20	0.50	30	0.70	1.00	A	12-10, 4-6
28Z652	28ZR652	1:2CT&1:1.36	1.20	0.50 & 0.80	35	0.80	1.80	B	12-10, 4-6
28Z653	28ZR653	1:2CT&1:1.14CT	1.20	0.55 & 0.80	40 & 35	0.70	1.20 & 0.90	A	12-10, 4-6
28Z654	28ZR654	1CT:2CT&1:1	1.20	0.80	30	0.70 & 1.00	1.10 & 0.70	D	1-3, 9-7
28Z665	28ZR665	1:1.15CT&1:2CT	1.50 & 1.20	0.60 & 0.50	35 & 40	0.70	1.10	A	12-10, 4-6
28Z666	28ZR666	1:1:1.26&1:2CT	1.50 & 1.20	0.50 & 0.40	35 & 40	0.70	0.90 & 1.10	A	12-10, 4-6
28Z668	28ZR668	1:1/1.26&1:1/1.26	1.50	0.40	45	0.80	1.00	E	12-10, 9-7
28Z669	28ZR669	1CT:2CT&1:1.08CT	1.20	0.60	40 & 30	0.70	1.10 & 0.90	F	12-10, 4-6
28Z674	28ZR674	2CT:1CT & 1:1	1.20	1.00	30	0.70	0.45	D	1-3, 4-6
Extend Temperature Range									
28Z626	28ZR626	1CT:2CT&1CT:2CT	1.20	0.80	50	1.00	1.70	C	12-10,4-6
28Z627	28ZR627	1CT:2CT&1:1.36CT	1.60	1.00 & 0.80	66 & 55	1.70	2.00 & 1.70	F	12-10,4-6
28Z628	28ZR628	1:1.15CT&1CT:2CT	1.60	0.80	60 & 50	1.00	1.00 & 2.00	G	12-10,4-6
28Z629	28ZR629	1:1/1.26&1:2CT	1.20	0.80	50 & 60	1.00	1.10 & 1.70	A	12-10,4-6
28Z630	28ZR630	1:2CT&2:1	1.60	1.30	55 & 40	1.10	1.10 & 0.70	H	1-3,4-6
28Z631	28ZR631	1CT:1CT&1CT:1CT	1.20	0.80	50	1.00	1.00	C	1-3,4-6
28Z632	28ZR632	1CT:1.15CT&1CT:1.15CT	1.20	0.80	50	1.20	1.40	C	1-3,4-6
28Z633	28ZR633	1CT:1CT&1CT:2CT	1.20	0.80	50	1.00	1.00 & 1.80	C	1-3,4-6
28Z634	28ZR634	1CT:1.15CT&1CT:1CT	1.60	0.80	60	1.20	1.40 & 1.20	C	12-10,4-6
28Z635	28ZR635	1CT:1.36CT&1CT:1.36CT	1.20	0.80	50	1.20	1.40	C	1-3,4-6
28Z636	28ZR636	1CT:1.41CT&1CT:1.41CT	1.20	0.80	50	0.90	1.20	C	12-10,9-7
28Z637	28ZR637	1CT:2.3CT&1CT:2CT	1.20	0.80	60 & 50	1.20	2.10	C	10-12,4-6

Add an "R" to the part number after "Z" for the RoHS compliant version (i.e. 28ZR651 is the RoHS compliant version of 28Z651).

TYPE 16Z - SINGLE THROUGH HOLE TRANSFORMERS

T1/E1 Extended Temperature Range

FEATURES

- Designed for T1/E1 telecom applications.
- Product matched to leading transceiver ICs.
- Designed to meet FCC and CCITT G.703.
- Meet UL 1459 and UL 1950.
- Dielectric test voltage: 1500 Vrms minimum.
- Dual transformer package available.

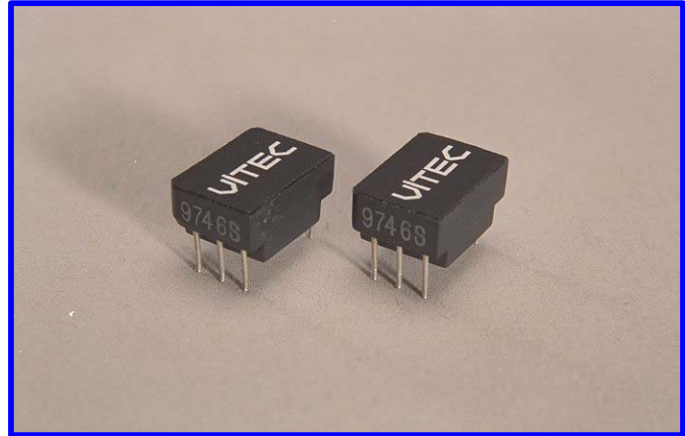

PACKAGE

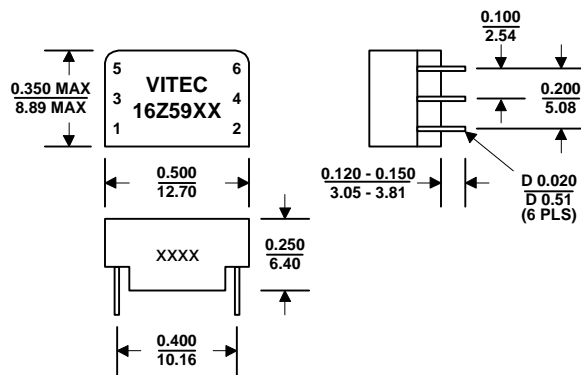

Drawing NOT to scale. Dimensions Inches/mm +/- 0.01" Unless noted

SCHEMATICS

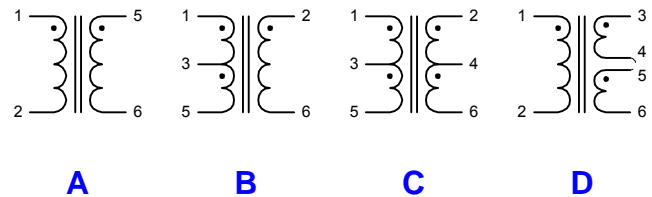

ELECTRICAL CHARACTERISTICS @ 25°C

Part Number	Turns Ratio	LP	LP @-40°C	Pri/Sec LL	Pri/Sec Cc	Pri. DCR	Sec. DCR	Schem.	Primary Pins
	Ratio +/- 5%	mH MIN	uH MIN	uH MAX	pF MAX	Ohms MAX	Ohms MAX		
16Z5981	1:1.36	1.20	600	0.80	35	0.90	1.20	A	5-6
16Z5982	1:1.15CT	1.50	600	0.80	40	0.90	1.00	B	2-6
16Z5983	1CT:2CT	1.20	600	0.60	45	1.00	2.00	C	2-6
16Z5984	1CT:1CT	1.20	600	1.10	50	1.00	1.00	C	1-5
16Z5985	1:1/1.26	1.50	600	0.80	50	0.90	1.10	B	2-6
16Z5986	1CT:3CT	1.20	600	1.50	40	0.35	0.97	C	1-5
16Z5987	1:1:1 (1:2SCT)	1.20	600	0.80	50*	0.90	0.90	D	1-2

Note: * Cc tested from pin 1 to pin 3 & 5.

TYPE 16Z - SINGLE THROUGH-HOLE TRANSFORMERS

T1/E1 Standard Temperature Range

FEATURES

- Designed for T1/E1 telecom applications.
- Product matched to leading transceiver ICs.
- Designed to meet FCC and CCITT G.703.
- Meet UL 1459 and UL 1950.
- Designed to meet EN60950:1993 +A1 +A2:1993, EN41003:1990.
- Dielectric test voltage: 1500 Vrms minimum.
- Extended temperature range and dual transformer package available.
- RoHS compliant version available.

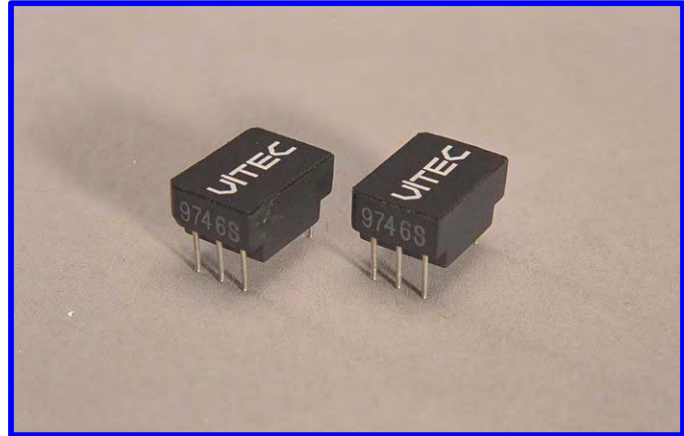

PACKAGE

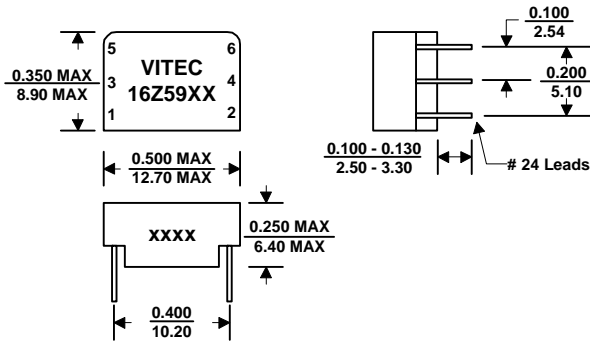

Dimensions Inches/mm +/- 0.01" Unless noted

SCHEMATICS

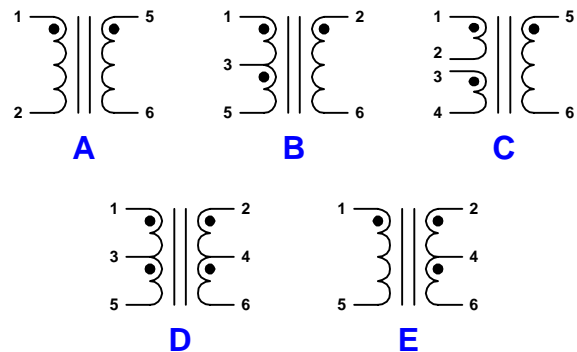

ELECTRICAL CHARACTERISTICS @ 25°C

Part Number		Turns Ratio	LP	Pri/Sec LL	Pri/Sec Cc	Pri DCR	Sec DCR	Schematic	Primary Pins
Classic	RoHS	Ratio	mH	uH	pF	Ohms	Ohms		
		+/- 5%	MIN	MAX	MAX	MAX	MAX		
16Z5924	16ZR5924	1CT:1	0.70	0.70	20	0.20	0.80	B	1-5
16Z5925	16ZR5925	1:1.36CT	0.70	0.70	20	0.50	0.40	E	1-5
16Z5931	16ZR5931	1:1:1(2CT)	1.20	0.50	25	0.70	0.70	C	1-2
16Z5932	16ZR5932	1CT:1CT	1.20	0.80	25	0.80	0.80	D	1-5
16Z5933	16ZR5933	1CT:3CT	1.20	0.50	30	0.70	1.60	D	1-5
16Z5934	16ZR5934	1:1	1.20	0.50	25	0.70	0.70	A	1-2
16Z5935	16ZR5935	1:1.36CT	1.20	0.80	35	0.70	0.90	E	1-5
16Z5936	16ZR5936	1CT:1	1.20	0.80	25	0.70	0.70	B	1-5
16Z5937	16ZR5937	1:1.36	1.20	0.80	34	0.70	0.70	A	5-6
16Z5940	16ZR5940	1.26SCT:1	0.30	0.60	30	0.80	0.60	C	1-4
16Z5941	16ZR5941	1SCT:1	0.80	0.60	30	0.80	0.60	C	1-4
16Z5942	16ZR5942	1SCT:1.31	0.80	0.40	30	0.80	0.60	C	1-4
16Z5943	16ZR5943	1:1.58:2	1.20	0.60	30	0.60	1.20	B	2-6
16Z5944	16ZR5944	2CT:1CT	2.00	1.50	30	0.70	0.70	D	1-5
16Z5945	16ZR5945	2.53CT:1	2.00	1.50	20	1.00	0.50	B	1-5
16Z5946	16ZR5946	1:2CT	1.20	0.50	40	0.70	1.10	B	2-6
16Z5948	16ZR5948	1:4CT	0.50	1.00	40	0.50	1.50	E	1-5
16Z5949	16ZR5949	1:1.14CT	1.20	0.80	35	0.70	0.80	E	1-5
16Z5950	16ZR5950	1CT:2CT	1.20	0.55	30	0.70	1.10	D	1-5
16Z5952	16ZR5952	1:1.15CT	1.50	0.60	35	0.70	0.90	B	2-6
16Z5953	16ZR5953	1:1:1.26	1.50	0.40	35	0.70	0.90	B	2-6
16Z5955	16ZR5955	1:0.63:0.63	1.50	1.10	20	0.70	0.50	C	5-6
16Z5961	16ZR5961	1CT:2.3CT	1.20	0.80	35	0.70	1.20	D	1-5

Add an "R" to the part number after "P" for the RoHS compliant version (i.e. 16ZR5924 is the RoHS compliant version of 16Z5924).

TYPE 24Z - DIL DUAL THROUGH HOLE TRANSFORMERS

T1/CEPT/ISDN-PRI

FEATURES

- Designed for T1/E1 telecom applications.
- Designed to meet or exceed FCC and CCITT G.703.
- UL 1459, file number E159135.
- Provides 1500 Vrms isolation minimum.
- Standard & extended temperature version available, please call factory.

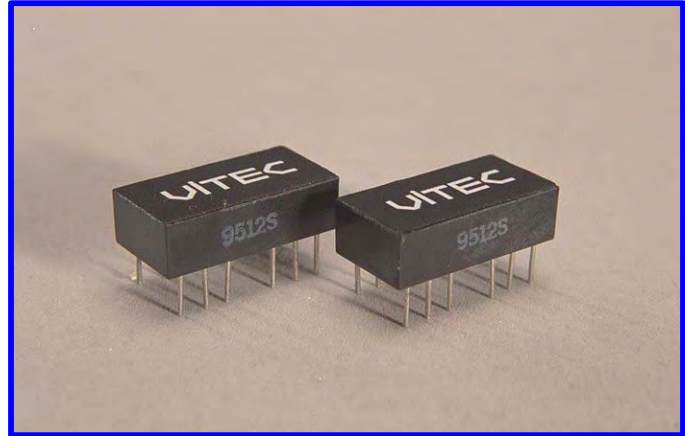

PACKAGE 1

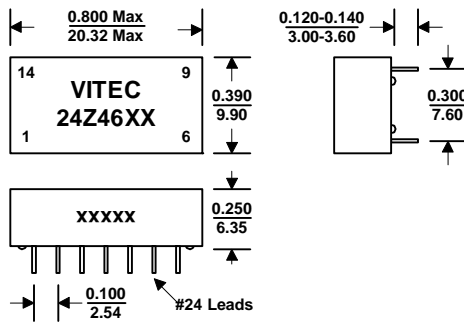

Drawing NOT to scale. Dimensions Inches/mm +/- 0.01" Unless noted

PACKAGE 2

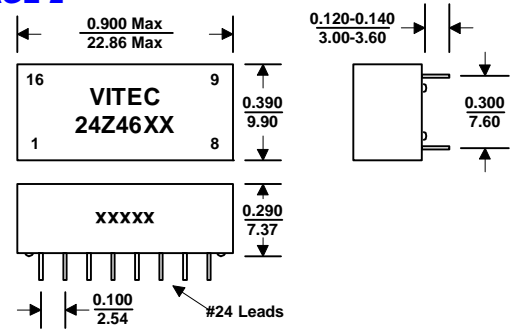

Drawing NOT to scale. Dimensions Inches/mm +/- 0.01" Unless noted

SCHEMATIC A

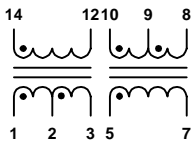

SCHEMATIC B

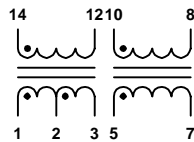

SCHEMATIC C

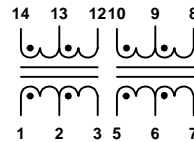

SCHEMATIC D

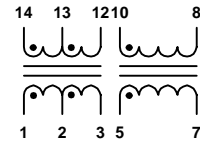

SCHEMATIC E

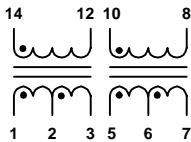

SCHEMATIC F

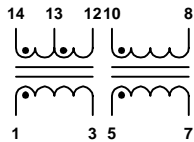

SCHEMATIC G

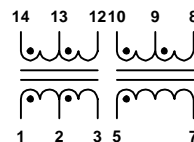

SCHEMATIC H

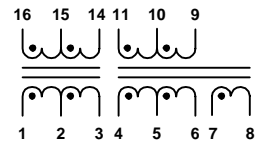

TYPE 24Z - DIL DUAL THROUGH HOLE TRANSFORMERS

T1/CEPT/ISDN-PRI

ELECTRICAL CHARACTERISTICS @ 25°C

Part Number	Turns Ratio	OCL	Pri/Sec LL	Pri/Sec CC	Primary DCR	Secondary DCR	Package & Schem.	Primary Pins
	Ratio	mH	uH	pF	Ohms	Ohms		
	+/- 5%	MIN	MAX	MAX	MAX	MAX		
Standard Temperature								
24Z4651	1:2CT&1:2CT	1.20	0.50	30	0.70	1.00	1A	14-12,5-7
24Z4652	1:2CT&1:1.36	1.20	0.50 & 0.80	35	0.80	1.80	1B	14-12,5-7
24Z4653	1:2CT&1:2CT	2.00	0.60	50	1.00	2.00	1E	14-12,10-8
24Z4654	1CT:2CT&1:1	1.20	0.55 & 0.50	30	0.70	1.10 & 0.70	1D	1-3,5-7
24Z4655	1:1.26CT&1.58:1	0.80	0.50	30	0.60	0.70 & 0.30	1F	1-3,5-7
24Z4656	1:1CT&2:1	0.80	0.60	30	0.50	0.50 & 0.20	1F	1-3,5-7
24Z4657	1CT:1.31&2.62:1	1.20	0.80	30	0.60	0.50 & 0.30	1F	1-3,5-7
24Z4661	1CT:1CT&1CT:2CT	1.20	0.55 & 0.50	30	0.70	0.70 & 1.10	1C	1-3,5-7
24Z4662	1:1.15CT&1:1.15CT	2.00	0.60	35	0.70	0.90	1E	14-12,10-8
24Z4663	1CT:2.3CT&1CT:2CT	1.20	0.80	35 & 30	0.70	1.00 & 1.10	1C	1-3,5-7
24Z4664	1CT:1.53CT&1CT:2CT	1.20	0.80	35 & 30	0.70	1.00 & 0.90	1C	1-3,5-7
24Z4665	1:1.15CT&1:2CT	1.50 & 1.20	0.60 & 0.50	35 & 40	0.70	1.10	1A	14-12,5-7
24Z4666	1:1:1.26&1:2CT	1.50 & 1.20	0.50 & 0.40	35 & 40	0.50	0.70 & 1.10	1A	14-12,5-7
24Z4667	1:1.36CT&1:1.36CT	2.40	0.80	35	0.70	0.90	1E	14-12,10-8
24Z4668	1CT:1.41CT&1.41CT:1CT	1.20	0.80	35	0.80	0.80	1C	1-3,10-8
Extend Temperature Range								
24Z4670	1:1.15CT&1:2CT	1.50 & 1.20	0.80 & 0.80	4. & 60	0.90 & 0.90	1.00 & 1.70	1A	14-12,5-7
24Z4671	1:1/1.26&1:2CT	1.50 & 1.20	0.80 & 0.80	50 & 60	0.90 & 0.90	1.00 & 1.70	1A	14-12,5-7
24Z4672	1CT:2CT&1:1.36CT	1.20 & 1.20	0.96 & 0.80	50 & 50	1.00 & 1.00	1.70 & 1.20	1G	14-12,5-7
24Z4673*	1CT:1CT&3CT:1CT:0.25	1.20 & 32.0	0.80 & 0.80	40 & 65	1.00 & 3.00	1.00 & 1.20	2H	1-3,11-9
24Z4674*	1CT:1CT&1CT:3CT:1	1.20 & 0.60	0.80 & 0.80	40 & 40	1.00 & 0.80	1.00 & 2.00	2H	1-3,4-6

Notes: * The fault locate winding is (7-8)

TYPE 18Z - 3K V_{RMS} REINFORCED INSULATION TRANSFORMERS

T1/CEPT/ISDN-PRI

FEATURES

- Reinforced Insulation per IEC 950: 1990 Mod., EN 60950: 1992 +A1 +A2: 1993, EN 41003: 1990.
- BAPT BS EN60950 recognized.
- Product matched to leading transceiver ICs.
- Designed to Meet FCC and CCITT G.703.
- UL 1459 & UL 1950.
- RoHS compliant version available.



PACKAGE

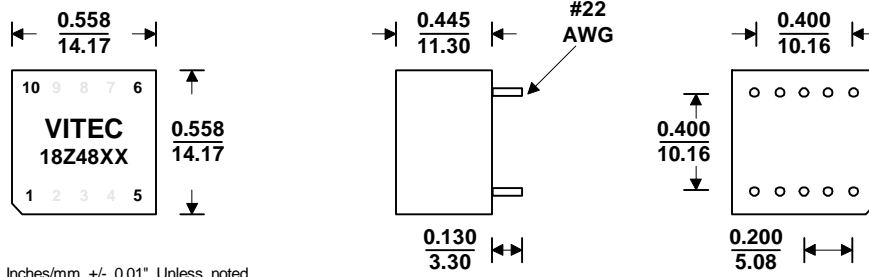

SCHEMATIC

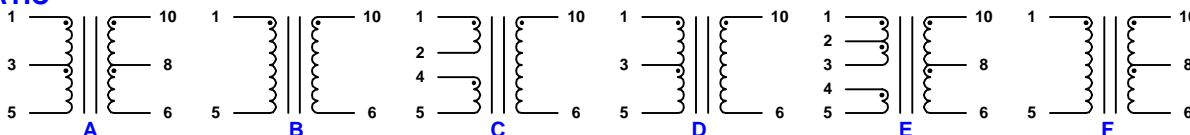

ELECTRICAL CHARACTERISTICS @ 25°C

Part Number		Turns Ratio	OCL	Leakage Inductance	Pri/Sec CC	Primary DCR	Secondary DCR	Schematic (Primary Pins)
Classic	RoHS		mH	uH	pF	Ohm	Ohm	
		+/- 5%	MIN	MAX	MAX	MAX	MAX	
18Z4877	18ZR4877	1:1.08/1.36	1.50	0.60	20	0.70	0.90	D (10-6)
18Z4880	18ZR4880	1.27SCT:1	0.60	0.70	25	0.70	0.50	C (1-5)
18Z4881	18ZR4881	1SCT:1	0.60	0.50	25	0.70	0.70	C (1-5)
18Z4882	18ZR4882	1:1.36CT	1.20	0.60	35	0.70	0.90	D (10-6)
18Z4883	18ZR4883	1:1.15CT	1.20	1.00	35	0.70	0.90	D (10-6)
18Z4884	18ZR4884	1:1	1.20	0.50	30	0.70	0.70	B (1-5)
18Z4885	18ZR4885	1CT:2CT	1.20	0.80	30	0.70	1.10	A (1-5)
18Z4886	18ZR4886	1CT:3CT:1	0.60	0.80	30	0.70	1.70	E (1-3)
18Z4887	18ZR4887	1:2.3CT	1.20	1.30	35	0.70	1.40	F (1-5)
18Z4888	18ZR4888	1:1.53CT	1.20	1.00	30	0.70	1.10	F (1-5)
18Z4889	18ZR4889	1:1:1.26	1.50	0.60	35	0.70	1.10	D (10-6)
18Z4890	18ZR4890	1:1.58/2	1.50	0.90	50	0.70	1.40	D (10-6)
18Z4891	18ZR4891	1CT:1.41CT	1.20	0.80	20	0.60	0.80	A (10-6)

Add an "R" to the part number after "P" for the RoHS compliant version (i.e. 18ZR4885 is the RoHS compliant version of 18Z4885).

TYPE 40Z - SMD TRANSFORMER MODULES

Quad Port T1/E1-DS1 Interface

FEATURES

- Four transmit and four Receive transformers.
- Complies with CCITT/ITU-TS G.703 requirements.
- 40 Pin low profile SMD package for Pick and Place manufacturing.
- Common footprints & pinouts.
- Standard and extended temperature range product available.

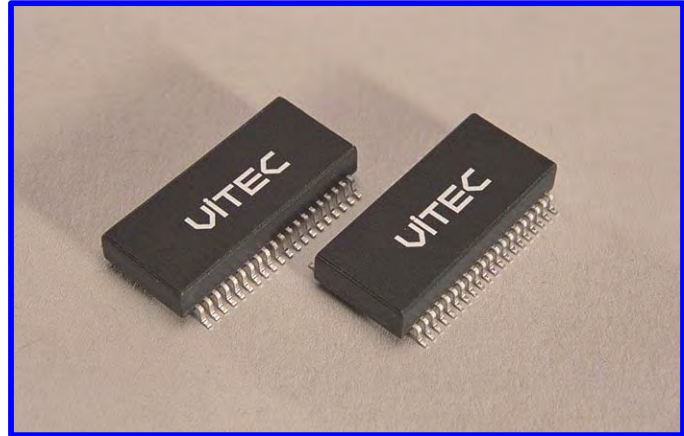

PACKAGE

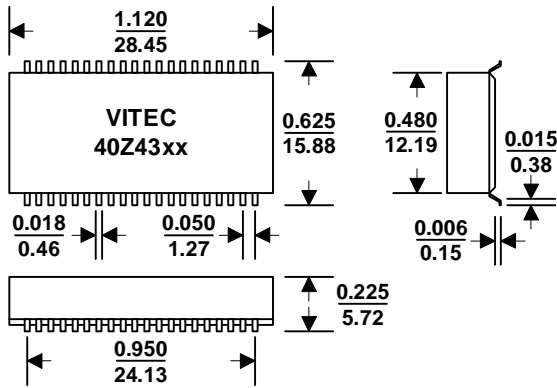

Drawing NOT to Scale. Dimensions Inches/mm +/- 0.005/0.127 Unless noted.

SCHEM. A

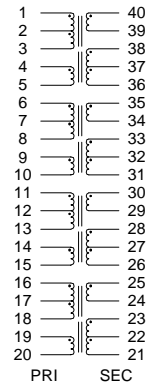

SCHEM. B

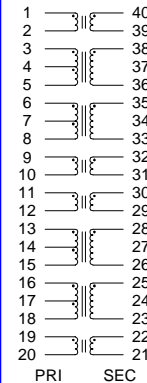

SCHEM. C

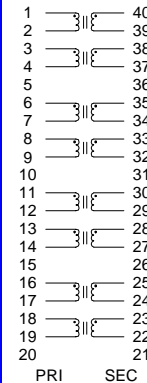

SCHEM. D

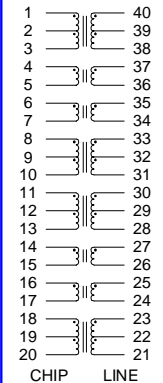

ELECTRICAL CHARACTERISTICS @ 25°C

Part Number	Turns Ratio		Xmt/Rcv LP	Pri/Sec Cc	Xmt/Rcv Pri LL	Xmt/Rcv Pri DCR	Xmt/Rcv Sec DCR	Dielectric Test	Schematic
	XMT	RCV	mH	pF	uH	Ohms	Ohms	Vrms	
	+/- 3%	+/- 3%	MIN	MAX	MAX	MAX	MAX	MIN	
40Z4300	1.14CT:1	1:1.14CT	1.50	35.00	0.80	1.00	2.00	1500	A
40Z4301	2CT:1	1:2CT	1.50	35.00	0.80	2.00/1.00	1.00/2.00	1500	A
40Z4302	1CT:1.41	1.41:1CT	1.20	35.00	0.80	1.00	2.00	1500	A
40Z4303	1.36CT:1	1:2CT	1.50	35.00	0.80	2.00/1.00	1.00/2.00	1500	A
40Z4333	1:1.36/2CT:1	2CT:1	1.20	35.00	0.80	0.80	1.20	1500	B
40Z4335	1:2	1:1	1.50	35.00	0.50	1.00/1.00	2.00/1.00	1500	C
40Z4337	1:1.36	1:1	1.20	35.00	0.40	0.70	0.70	2000	D
40Z4338	1:2	2CT:1	1.50	35.00	0.50	0.80	0.80	1500	B
40Z4339	1:1.15	1:1	1.50	35.00	0.40	0.70/0.70	0.85/0.70	1500	C

Notes: .

ADSL TRANSFORMERS

SELECTION GUIDE

IC Manufacturer	IC P/N	Application	Vitec P/N	
			THT	SMD
Alcatel	MTK-20131	CPE	70Z7159	60Z959
	MTK-20140	CPE	--	60Z924
	MTK-20140	CO	70Z7124	--
Analog Device	ADmsp910/918	CO/CPE	70P7118	60P918
	ADmsp910/918	--	70P7128	60P928
	ADmsp930	--	70Z7136J	60Z936J
Broadcom	BCM6010	VDSL	24Z4691	34Z2261
Centillium	CTL10AT01-1T	--	call factory	60Z952
	CTL20ST01	Uses linear tech driver	70P7118	60P918
	CTL22SU15	--	70P7118	60P918
Conexant/Rockwell	CN9001	CO/CPE	70Z7145	60Z945
	CN9001	--	70Z7158	60Z958
	328R57-001	--	--	60Z935
General	600Hz-2.5MHz	Bandwidth 600Hz-2.5MHz	70Z7137	60Z937
	--	ADSL/CMC	18Z4825	28Z503
Globespan	EL-1501	CO	--	60Z954
	EL-1501	CO	70Z7139	--
	EL-1501	CPE	70Z7103	--
	EL-1501	CPE	--	60Z920
	RADSL Lite	CPE	--	68Z6251
	RADSL Lite	CO	--	68Z6250
	RADSL Lite	CO	--	68Z6252
	RADSL Lite	CPE	--	68Z6253
	ADSL	--	33Z3837	63Z6337
	ADSL	--	33Z3838	63Z6338
	Itex	ADSL	CPE	70Z7124
ADSL		CPE	--	60Z925
Lucent	DSP 1690 Wildwire/Tiger	Line isolation	70Z7114	60Z914
	DSP 1690 Wildwire/Tiger	5V signal boost	70Z7121	--
Motorola	MC03AX1456RT	CPE	70Z7149	60Z949
	MC03AX1456RT	CPE	70Z7134	60Z934
	MC03AX1456CO	CO	70Z7142	60Z942
	MC03AX1456CO	CO	70Z7148	60Z948
Texas Instrument	THS6012	ADSL	call factory	call factory
	TNETD3000C/P	CPE	70Z7129	60Z929
	TNETD3000C/P	CPE	70Z7131	60Z931
	TNETD3000C/P	CPE	70Z7130	60Z930
	TNETD3000C/P	CPE	70Z7132	60Z932
	TNETD4000R	--	70Z7129	60Z929

Please contact the factory for other selections not listed on this page.

TRANSFORMERS IN SMD OR THT PACKAGES

ADSL Applications

FEATURES

- Designed for digital telecom applications.
- Product matched to leading transceiver ICs.
- Standard 10 pin SMD or THT packages.
- Designed to exceed ANSI and ETSI standards.
- Excellent total harmonic distortion.
- Recognized to TNV-3 under IEC60950/EN60950.
- Other designs available.

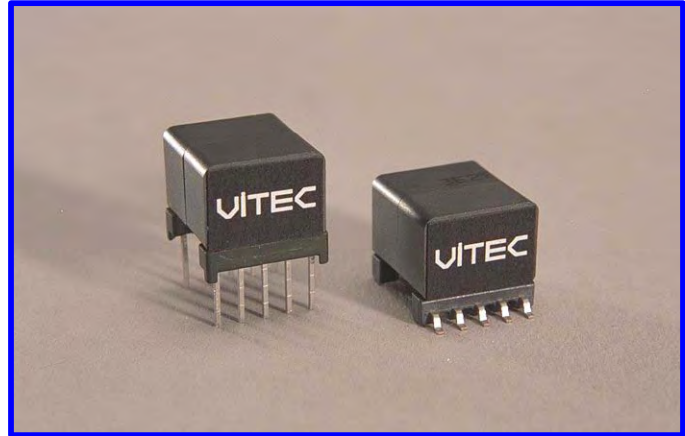

70Z71xx

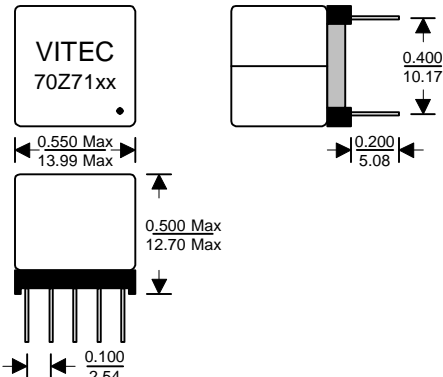

Drawing NOT to Scale. Dimensions Inches/mm. +/- 0.005/0.127 Unless noted.

60Z9xx

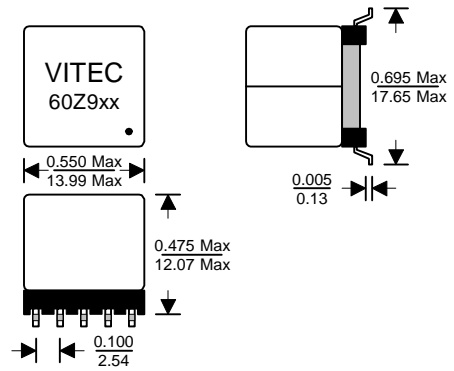

Drawing NOT to Scale. Dimensions Inches/mm. +/- 0.005/0.127 Unless noted.

SCHEMATIC A

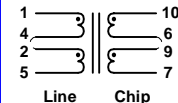

SCHEMATIC B

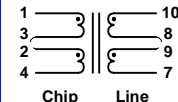

SCHEMATIC C

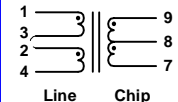

ELECTRICAL CHARACTERISTICS @ 25°C

Part Number		Turns Ratio	LP ⁽¹⁾	LL ⁽²⁾	Cc ⁽³⁾	Primary DCR	Secondary DCR	Dielectric Strength	THD	Insertion Loss	Longitudinal Balance	
SMD	THT	Ratio	mH	uH	pF	Ohms	Ohms	Vrms	dB	dB	dB	
		+/- 2%	+/- 6%	MAX	MAX	+/- 10%	+/- 10%	MIN	NOM	MAX	MIN	
60Z918	70Z7118	B	(1-4:10-7) 1:1	(1-4) 5.00	18	--	(1-4) 3.00	(10-7) 3.00	1500	-80 dB @30KHz	0.5 dB @100KHz	40 dB
60Z934	70Z7134	A	(1-4:2-5/10-6:9-7) 1:1/1:1	(1-5:10-7) 1:1.8	(1-5) 3.96	(1-5,sht 10-7) 22	(1-10) 60	(1-4:2-5) 2.20/2.20	(10-6/9-7) 4.55/4.85	1875	--	--
60Z936	70Z7136	B	(1-4:10-7) 1:1.1	(1-4) 1.75	(1-4,sht 10-7) 7.5	--	(1-4) 1.50	(10-7) 1.30	1875	-80 dB @30KHz	0.5 dB @300KHz	--
60Z942	70Z7142	A	(1-4:2-5:10-6:9-7) 1.2:1.2:1:1	(1-4) 3.96	18	60	(1-4:2-5) 2.52/2.52	(10-6/9-7) 2.42/1.87	1875	--	1.5 dB @772KHz	40 dB @20KHz-1.1MHz
60Z948	70Z7148	C	(1-3:2-4/1-4:9-7) 1:1/1.2:1	(1-4) 3.96	(1-4,sht 9-7) 18	--	(1-3:2-4) 2.1/2.1	(9-7) 4.40	1875	--	--	--
60Z949	70Z7149	C	(1-3:2-4/1-4:9-7) 1:1/1:1.8	(1-4) 3.96	(1-4,sht 9-7) 18	--	(1-3:2-4) 2.04/2.04	(9-7) 7.40	1875	--	--	--
60Z956	70Z7156	B	(1-4:10-7) 1:1.2	(1-4) 1.75	(1-4,sht 10-7) 7.5	--	(1-4) 1.50	(10-7) 1.30	1875	-80 dB @30KHz	--	--

Notes: (1) Tested @10KHz, 0.1V
 (2) Tested @100KHz, 0.1V
 (3) Tested @10KHz, 1.0V
^A All tests performed with pin 2 tied to pin 4, pin 6 tied to pin 9.
^B All tests performed with pin 2 tied to pin 3, pin 8 tied to pin 9.
^C All tests performed with pin 2 tied to pin 3.

TRANSFORMERS IN SMD OR DIP PACKAGES

ADSL & RADSL applications

FEATURES

- Designed to meet or exceed standards for ANSI and ETSI.
- Products matched to leading transceiver ICs.
- Dielectric test voltage: 3000 Vrms minimum.

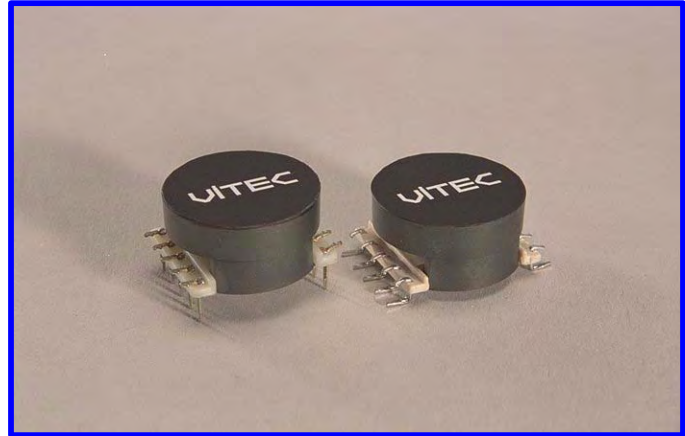

PACKAGE THT

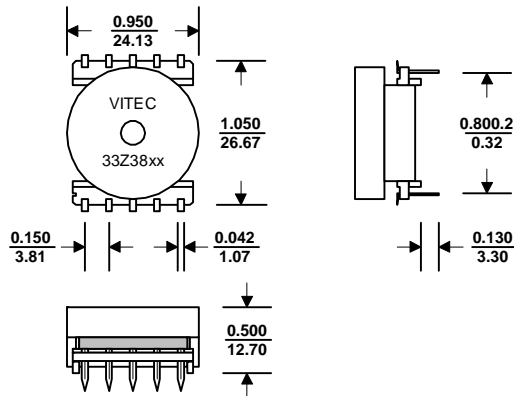

Drawing NOT to Scale. Dimensions Inches/mm. +/- 0.005/0.127 Unless noted.

PACKAGE SMD

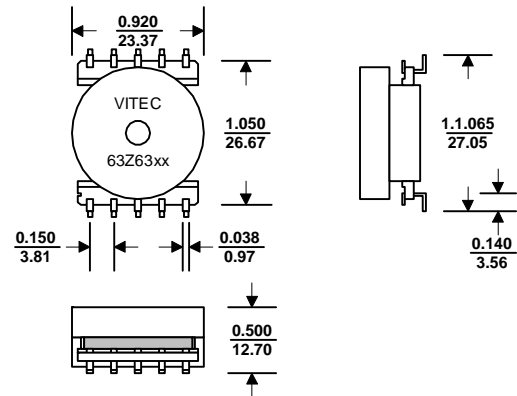

Drawing NOT to Scale. Dimensions Inches/mm. +/- 0.005/0.127 Unless noted.

ELECTRICAL CHARACTERISTICS @ 25°C

Part Number		Turns Ratio	LP*	LL	Cc	DCR	Dielectric Strength	Insertion Loss	Longitudinal Balance
		Ratio	uH +/- 10%	uH	pF	Ohms	Vrms	dB	dB
THT	SMD	+/- 5%	MIN	MAX	MAX	MAX	MIN	MAX	TYP
33Z3837	63Z6337	1.4:1.4:1:1	940	10	--	1.20	3000	3	62
33Z3838	63Z6338	1:1:1:1	410	10	--	0.80	3000	3	62

Notes: * Test pin 1-4 with pin 2-3 shorted

TRANSFORMER SELECTION GUIDE

T3/DS3/E3/STS-1 INTERFACE

IC Manufacturer	IC P/N	Single SMD				Single THT		Single THT 3kVrms		Dual SMD Ext Temp
		Std Temp		Ext Temp		XMT	RCV	XMT	RCV	XMT & RCV
		XMT	RCV	XMT	RCV					
Conexant / Rockwell	CN8331/2/3	26Z086	26Z086	26Z086E/E1	26Z086E/E1	14Z3276	14Z3276	16Z5795	16Z5795	46Z202E*
Exar Corporation	XRT73L00, L03, L04	26Z086	26Z086	26Z086E/E1	26Z086E/E1	14Z3276	14Z3276	16Z5795	16Z5795	46Z202E*
	XRT7300, XRT7302	26Z086	26Z086	26Z086E/E1	26Z086E/E1	14Z3276	14Z3276	16Z5795	16Z5795	
	XRT7296, XRT7298	26Z086		26Z086E/E1		14Z3276		16Z5795		
	XRT7295, XRT7295E		26Z086		26Z086E/E1	14Z3276		16Z5795		
Infineon Technologies	PEB3452				26Z086E/E1					
Lucent Technologies	T7296	26Z086		26Z086E/E1		14Z3276		16Z5795		
Silicon Systems	SSI 78P236 DS3	26Z087	26Z086	26Z087E/E1	26Z086E/E1	14Z3277	14Z3276	16Z5796	16Z5795	46Z202E
	SSI 78P2361 STS1	26Z087	26Z086	26Z087E/E1	26Z086E/E1	14Z3277	14Z3276	16Z5796	16Z5795	
	SSI 78P2362 E3	26Z087	26Z086	26Z087E/E1	26Z086E/E1	14Z3277	14Z3276	16Z5796	16Z5795	
	SSI 78P7200 DS3	26Z087	26Z086	26Z087E/E1	26Z086E/E1	14Z3277	14Z3276	16Z5796	16Z5795	
	SSI 78P7200 E3	26Z087	26Z087	26Z087E/E1	26Z087E/E1	14Z3277	14Z3277	16Z5796	16Z5796	
TDK Semiconductor	78P2244/43/42/41	26Z087	26Z086	26Z087E/E1	26Z086E/E1	14Z3277	14Z3276	16Z5796	16Z5795	46Z202E
	78P2362, 78P2361	26Z087	26Z086	26Z087E/E1	26Z086E/E1	14Z3277	14Z3276	16Z5796	16Z5795	46Z202E
	78P7200	26Z087	26Z087	26Z087E/E1	26Z087E/E1	14Z3277	14Z3277	16Z5796	16Z5796	46Z202E
	78P7200L	26Z087	26Z086	26Z087E/E1	26Z086E/E1	14Z3277	14Z3276	16Z5796	16Z5795	46Z202E
Transwitch	ART TXC-02020	26Z086	26Z086	26Z086E/E1	26Z086E/E1	14Z3276	14Z3276	16Z5795	16Z5795	46Z202E*
	ARTE TXC-02021	26Z086	26Z086	26Z086E/E1	26Z086E/E1	14Z3276	14Z3276	16Z5795	16Z5795	46Z202E*
	DART TXC-2030, DS3	26Z086	26Z086	26Z086E/E1	26Z086E/E1	14Z3276	14Z3276	16Z5795	16Z5795	46Z202E*
	DART TXC-2030, E3	26Z087	26Z086	26Z087E/E1	26Z086E/E1	14Z3277	14Z3276	16Z5796	16Z5795	46Z202E
	DS3LIM-SN TXC20153G	26Z086	26Z086	26Z086E/E1	26Z086E/E1	14Z3276	14Z3276	16Z5795	16Z5795	46Z202E*
	E3LIM TXC-20163	26Z087	26Z086	26Z087E/E1	26Z086E/E1	14Z3277	14Z3276	16Z5796	16Z5795	46Z202E
	MRT TXC-02050 E3	26Z087	26Z086	26Z087E/E1	26Z086E/E1	14Z3277	14Z3276	16Z5796	16Z5795	46Z202E

Notes: * For those applications that requires a 1:1 turns ratio on the transmit (xmt) side, please use only one half of the second (2CT) winding.

Please contact the factory for other selections not listed on this page.

INTERFACE TRANSFORMERS

T3/E3/DS3/STS-1

FEATURES

- Developed for use in T3, E3, DS3, and STS-1 interfaces.
- Designed to meet or exceed CCITT G.703 & AT&T T.A.34 pulse templates.
- Suitable for Bellcore STS-1 applications.
- Both SMD and Through Hole packages available.
- 1500 Vrms Basic and 3000 Vrms Reinforced insulation per BS EN60950: 1993.
- RoHS Compliant version available for most THT parts.

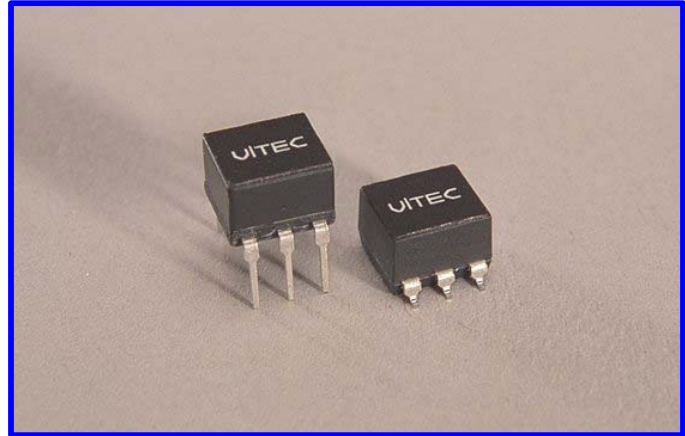

ELECTRICAL CHARACTERISTICS @ 25°C

Part Number		Turns Ratio	OCL	OCL @ -40°C	Pri/Sec LL	Pri/Sec CC	Pri/Sec DCR	3db** Bandwidth	Dielectric strength	Primary Pins	Package & Schematic
Classic	RoHS		uH MIN	uH MIN	uH MAX	pF MAX	Ohm MAX	MHz TYP	Vrms MIN		
THT											
14Z3275	N/A	1:1.73CT	50	--	0.10	12	--	0.060-300	1500	4-6	1B
14Z3276	N/A	1:1	40	--	0.10	9.5	0.20	0.200-340	1500	4-6	1D
14Z3277	N/A	1:2CT	19	--	0.06	9.5	0.20	0.250-500	1500	4-6	1B
16Z5795	16ZR5795	1:1	40	--	0.10	5	--	--	3000	1-5	2A
16Z5796	16ZR5796	1:2CT	19	--	0.06	10	--	--	3000	1-5	2C
16Z5934	16ZR5934	1:1	120	--	0.50	25	0.70	--	1500	1-2	2E
SMD											
26Z086	N/A	1:1	40	--	0.10	9.5	0.20	0.200-340	1500	4-6	3D
26Z087	N/A	1:2CT	19	--	0.06	9.5	0.20	0.250-500	1500	4-6	3B
26Z086E	N/A	1:1	45	30	0.12	9.5	0.20	0.200-340	1500	4-6	4D
26Z087E	N/A	1:2CT	40	19	0.06	9.5	0.20	0.250-500	1500	4-6	4B
26Z086E1	N/A	1:1	100	40	0.11	10	0.20	0.200-340	1500	4-6	3D
26Z087E1	N/A	1:2CT	40	19	0.06	9.5	0.20	0.250-500	1500	4-6	3B
46Z202E	N/A	1:2CT / 1:1	40 / 100	19 / 40	0.10 / 0.11	10 / 10	0.12 / 0.20	0.200-340	1500	16-14 / 6-8	5F

Add an "R" to the part number after "Z" for the RoHS compliant version (i.e. 16ZR5795 is the RoHS compliant version of 16Z5795).

Notes: ** Measured in 0.75 Ohm system

INTERFACE TRANSFORMERS

T3/E3/DS3/STS-1

PACKAGE 1

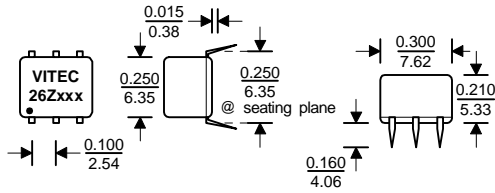

Dimensions Inches/mm +/- 0.01" Unless noted

PACKAGE 4

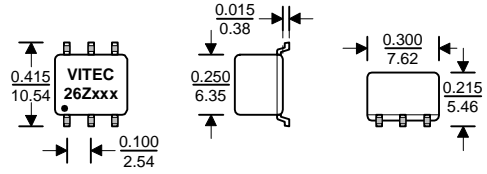

Dimensions Inches/mm +/- 0.01" Unless noted

PACKAGE 2

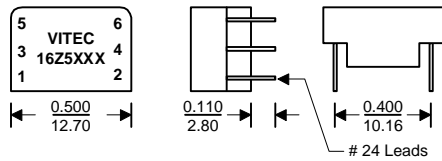

Dimensions Inches/mm +/- 0.01" Unless noted

PACKAGE 5

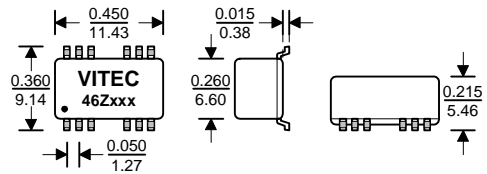

Dimensions Inches/mm +/- 0.01" Unless noted

PACKAGE 3

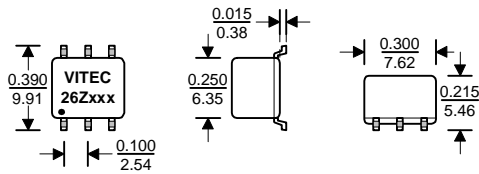

Dimensions Inches/mm +/- 0.01" Unless noted

SCHEMATICS

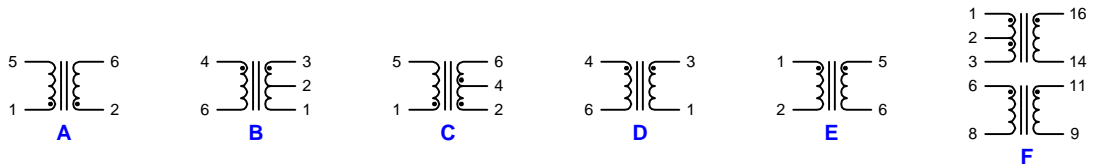

NOTES:

TYPE 18Z - SINGLE THROUGH-HOLE TRANSFORMERS

ISDN-S Interface

FEATURES

- Designed for ISDN S/T telecom applications.
- Meets CCITT I.430 pulse template.
- 1500 Vrms, basic insulation per IEC 950:1991, Mod. EN60950:1992 +A1 +A2:1993, EN41003:1990
- BAPT BS EN60950 approval # 1810.

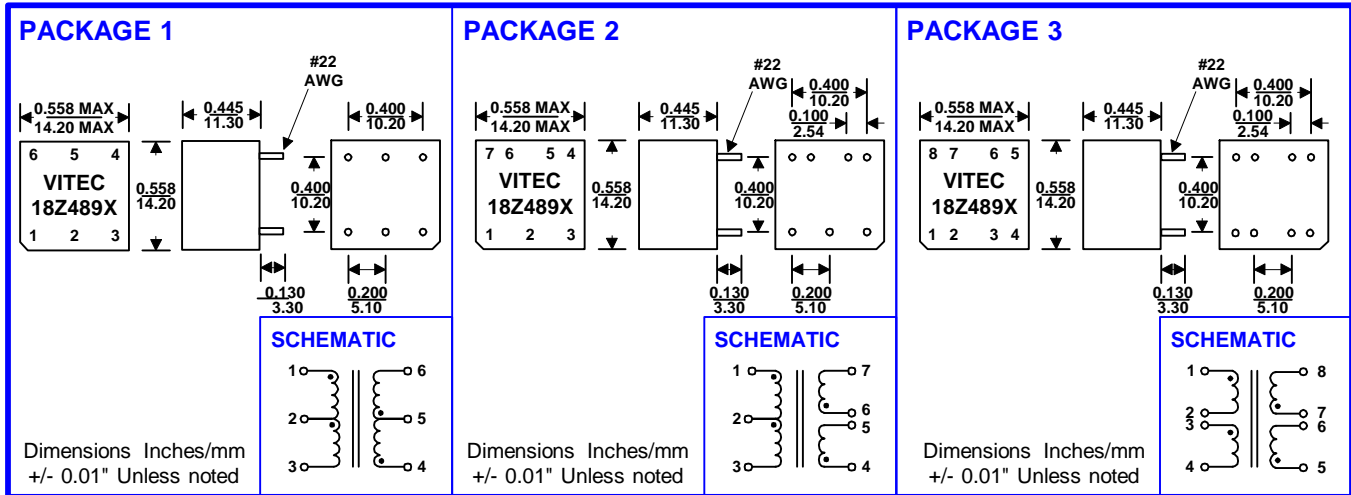
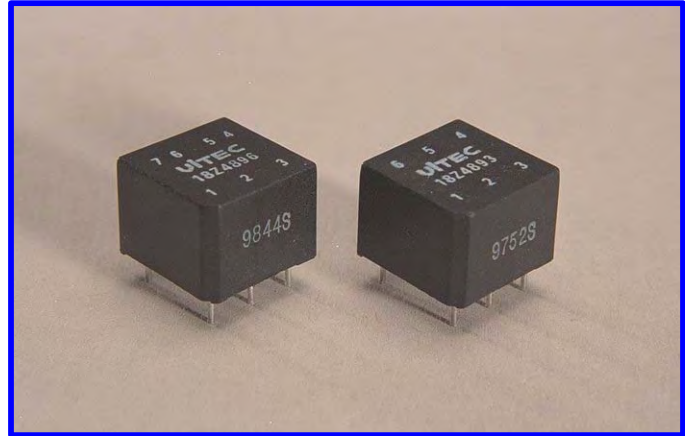

ELECTRICAL CHARACTERISTICS @ 25°C

Part Number	Turns Ratio	OCL	Pri/Sec LL	Pri/Sec Cc	Primary DCR	Secondary DCR	Package
	Ratio	mH	uH	pF	Ohms	Ohms	
	+/- 5%	MIN	MAX	MAX	+/- 25%	+/- 25%	
18Z4893	1CT:1CT	22	10	130	2.4	2.4	1
18Z4894	1CT:1.8SCT	22	10	120	2.4	4.2	2
18Z4895	1CT:2CT	22	15	120	2.5	4.6	1
18Z4896	1CT:2.5SCT	22	12	125	2.5	5.5	2
18Z4897	1CT:2CT	22	35	120	2.5	4.8	1
18Z4898	1SCT:2.5SCT	22	40	100	2.5	5.8	3
18Z4899	1CT:2CT	22	11	100	2.4	4.4	1

3000 VRMS REINFORCED TRANSFORMERS

Single ISDN-S Interface

FEATURES

- Designed for ISDN S telecom applications.
- Meets CCITT 1.430 pulse template.
- 3000 Vrms reinforced insulation.
- Materials meet flammability requirement of UL94V-0.

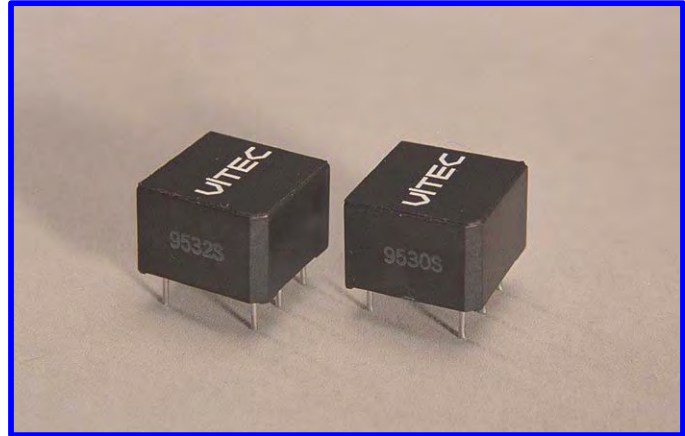

PACKAGE

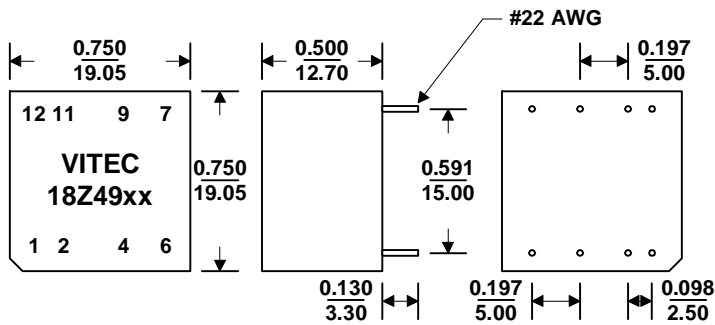

Dimensions Inches/mm +/- 0.01" Unless noted

SCHEMATIC A

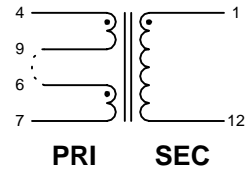

SCHEMATIC B

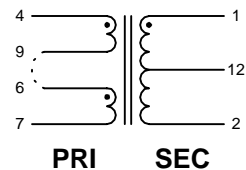

ELECTRICAL CHARACTERISTICS @ 25°C

Part Number	Turns Ratio	OCL	Pri/Sec LL	Pri/Sec Cc	Primary DCR	Secondary DCR	Unbalanced I _{bc}	Schematic
	Ratio +/- 5%	mH MIN	uH MAX	pF MAX	Ohms MAX	Ohms MAX	mAmp MAX	
	18Z4901	1SCT:2.5	22	8-40	40	3.0	7.0	
18Z4902	1SCT:2CT	22	15	60	3.0	5.5	5.0	B
18Z4905	1SCT:2	22	15	60	3.0	5.5	5.0	A
18Z4909	1SCT:2	22	11	50	2.8	5.5	5.0	A
18Z4913	1SCT:1	22	5	40	2.8	2.7	5.0	A

TYPE 24Z - ISOLATION TRANSFORMERS

Dual ISDN S Interface

FEATURES

- Designed for ISDN S/T telecom applications.
- Meets CCITT 1.430 pulse template.
- 1500 Vrms, basic insulation per IEC 950:1991, Mod. EN60950:1992 +A1 +A2:1993, EN41003:1990
- BAPT BS EN60950 recognition pending.

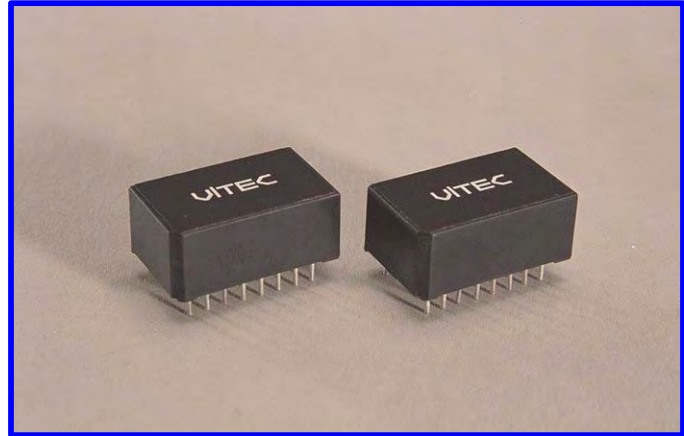

PACKAGE

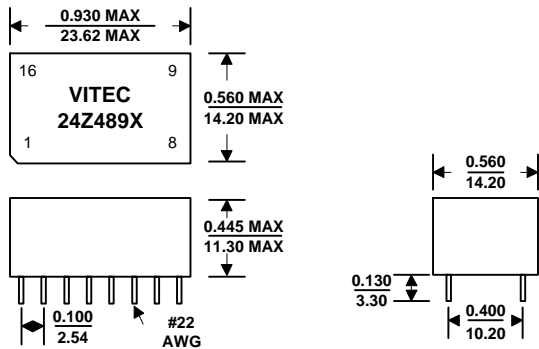

SCHEMATIC

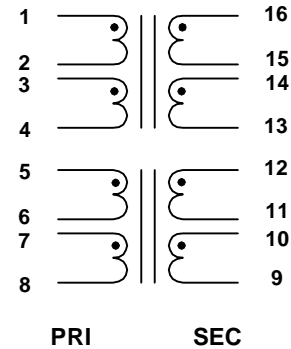

ELECTRICAL CHARACTERISTICS @ 25°C

Part Number	Turns Ratio	OCL	Pri/Sec LL	Pri/Sec Cc	Primary DCR	Secondary DCR	Primary Pins
	Ratio	mH	uH	pF	Ohms	Ohms	
	+/- 5%	MIN	MAX	MAX	+/- 25%	+/- 25%	
24Z4892	1:1&1:2	22	5	100	2.4	2.4	1-4, 5-8
24Z4893	1:1&1:1	22	5	130	2.4	2.4	1-4, 5-8
24Z4894	1:1.8 & 1:1.8	22	10	120	2.5	2.4	1-4, 5-8
24Z4895	1:2&1:2	22	15	120	2.5	4.6	1-4, 5-8
24Z4896	1:2.5&1:2.5	22	30	125	2.5	5.8	1-4, 5-8
24Z4897	1:2&1:2	22	35	120	2.5	4.8	1-4, 5-8
24Z4898	1:2.5&1:2.5	22	40	100	2.5	5.8	1-4, 5-8
24Z4899	1:2&1:2	22	11	100	2.4	4.4	1-4, 5-8

TYPE 18Z - INTERFACE TRANSFORMERS

ISDN-S

FEATURES

- Product matched to most IC manufacturers.
- Designed to meet or exceed CCITT I.430 pulse template.
- Common footprints & pinouts.
- Designed to IEC950, 3000 Vrms reinforced insulation system.

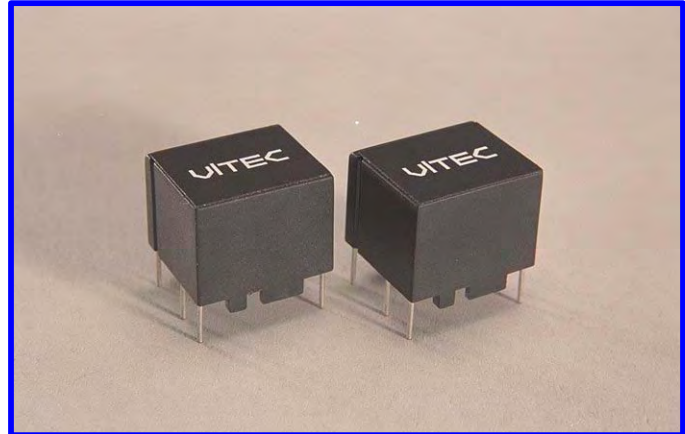

PACKAGE

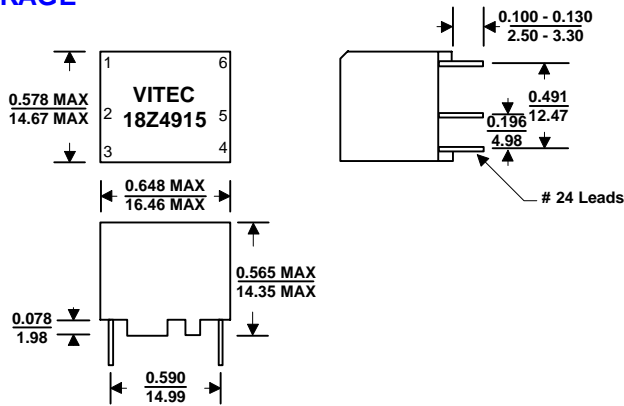

Drawing NOT to scale. Dimensions Inches/mm +/- 0.01" Unless noted.

SCHEMATIC

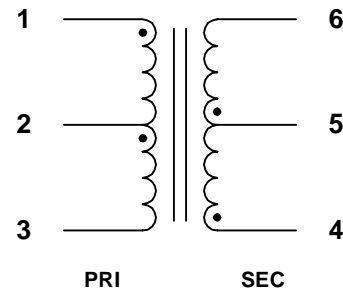

ELECTRICAL CHARACTERISTICS @ 25°C

Part Number	Turns Ratio	LP*	Cc	Sec LL	Pri DCR	Sec DCR	Ibc	Primary Pins
		mH	pF	μH	Ohm	Ohm	mAmp	
		MIN	MAX	MAX	MAX	MAX	MAX	
18Z4915	1CT:2CT	30	75	15	3.4	5.4	5	1-3

Recommended Common Mode Chokes

Part Number	Number of Lines	Inductance	Peak Common Mode Attenuation	TYPE	Application	Isolation Voltage	DCR (Ohms MAX)
18Z4854	4-Line	4.7mH+/-30%	1 MHz	Low Frequency	Improve Balance	500 Vrms	1.00
18Z4814	4-Line	50uH Min	50 MHz	High Frequency	EMI Reduction	500 Vrms	0.30

Chip Set Selection Guide

IC Manufacturer	IC Part Number
AMD	AM79C 30A/32A
Lucent	T7903
Mietec	MTC-2072
Mitel	MT8930 / 8931
National	TP3420 / 3421
SGS Thomson	ST5420 / 5421
Siemens	PEB2080 / 2081 / 2084 / 2085 / 2086 PSB 2186
Yamaha	7405B

Notes:

TYPE 22Z - DUAL TRANSFORMER MODULES

ISDN-S Interface

FEATURES

- Product matched to most IC manufacturers.
- Designed to meet or exceed CCITT I.430 pulse template.
- Common footprints & pinouts.
- Excellent longitudinal balance.
- 1500 Vrms isolation voltage.
- Developed for enhanced EMI performance.

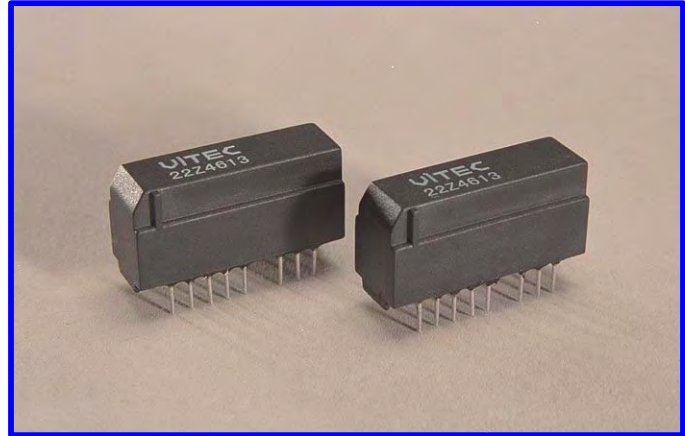

PACKAGE

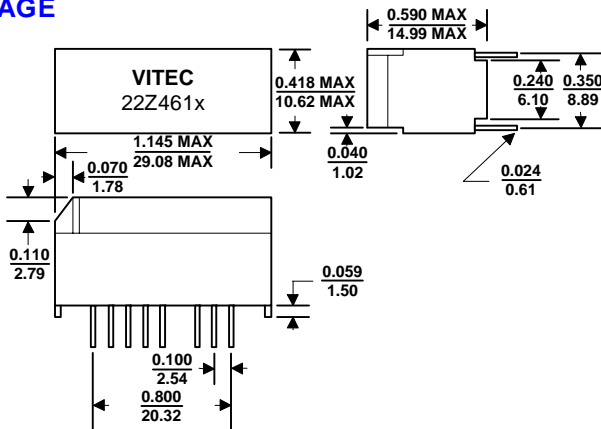

Drawing NOT to scales. Dimensions Inches/mm +/- 0.01" Unless noted

SCHEMATIC

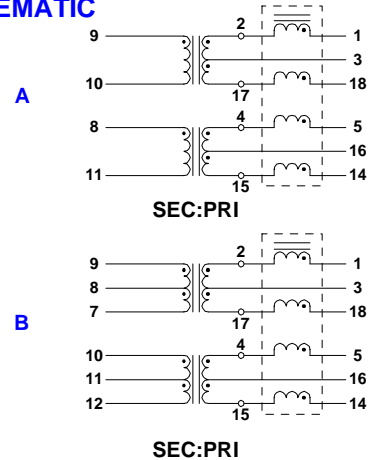

ELECTRICAL CHARACTERISTICS @ 25°C

Part Number	Turns Ratio	OCL Pri	Pri/Sec LL	Pri/Sec CC	Pri CD	Pri DCR	Sec DCR	Choke		IDC	Sec Pins	Schem.
								OCL	DCR			
								mH	Ohm			
	+/- 2%	MIN	MAX	pF	pF	Ohm	Ohm	mH	Ohm	mA		
				MAX	MAX	MAX	MAX	MIN	MAX	MAX		
22Z4611	1CT:1CT	30	5	150	100	4.0	4.0	4.7	1.5	5	9-7, 10-12	B
22Z4612	1CT:2CT	30	30	150	100	4.0	6.7	4.7	1.5	5	9-7, 10-12	B
22Z4613	1CT:2.5CT	30	30	150	110	4.0	9.0	4.7	1.5	5	9-7, 10-12	B
22Z4615	1CT:2	30	30	150	100	4.0	6.7	4.7	1.5	5	9-10, 8-11	A*

Module Selection Guide

IC Manufacturer	IC Part Number	Module Part Number
AMD	AM79C 30A/79C	22Z4612 / 22Z4614
Lucent (AT&T)	T7234 / T7254 / T7250 / T7256 / T7259	22Z4613
	T7903	22Z4612 / 22Z4614
Mietec	MTC-2072	22Z4612 / 22Z4614
Mitel	MT8930 / MT8931	22Z4612 / 22Z4614
Motorola	MC145474 / MC145475	22Z4611
	MC145574	22Z4613
National	TP3420 / 3421	22Z4612 / 22Z4614
SGS Thomson	ST5420 / 5421	22Z4612 / 22Z4614
Siemens	PEB2080 / PEB2081 / PEB2084 / PEB2085 / PEB2086	22Z4612 / 22Z4614
	PSB2186	22Z4612 / 22Z4614
Yamaha	7405B	22Z4612 / 22Z4614

Notes: *Pin 7 & 12 are not included in this package.

TYPE 32Z - SMD SINGLE TRANSFORMERS

ISDN S-Interface

FEATURES

- Designed to meet FCC and CCITT I.430
- 1.5Kv and 3Kv reinforced to meet IEC950.
- SMD with 1.5Kv and 3Kv compatible footprints.
- Suitable for Terminal, Line card, and NT box applicatons.

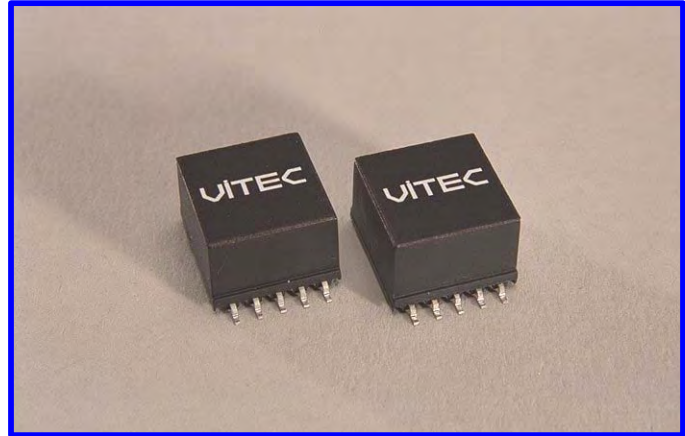

PACKAGE

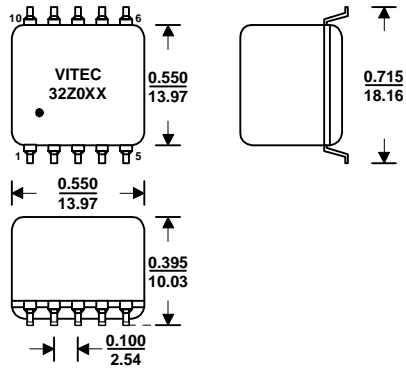

Dimensions Inches/mm +/- 0.01" Unless noted

SCHEMATICS

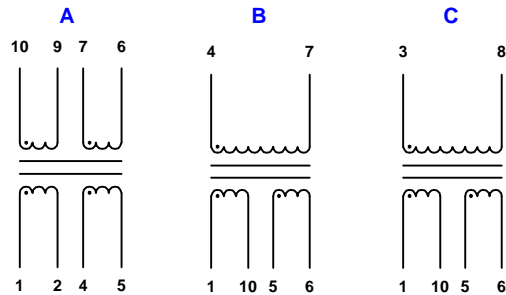

ELECTRICAL CHARACTERISTICS @ 25°C

Part Number	Turns Ratio	OCL	Pri/Sec LL	Pri/Sec CC	Pri CD	Pri DCR	Sec DCR	I _{dc}	Dielectric Test	Primary Pins	Schem.								
												mH	uH	pF	pF	Ohm	Ohm	mA	V _{rms}
												MIN	MAX	MAX	MAX	MAX	MAX	MAX	MIN
32Z2450	1:2	22	5	120	180	2.5	5.2	3	1500	1-10,5-6	B								
32Z2451	1:1	22	5	120	180	2.5	2.5	3	1500	1-10,5-6	C								
32Z2452	1:2.5	22	10	150	180	2.5	6	3	1500	1-10,5-6	C								
32Z2453	1:2	22	5	120	180	2.5	5	3	1500	1-10,5-6	C								
32Z2454	1:2	22	15	45	100	1.3	3.0	3	3000	6-7,9-10	A								
32Z2455	1:1	22	15	45	100	1.3	1.3	3	3000	6-7,9-10	A								
32Z2456	1:2.5	22	15	45	100	1.3	3.5	3	3000	6-7,9-10	A								
32Z2457	1:2	22	15	120	180	1.3	3.0	3	1500	6-7,9-10	A								
32Z2458	1:2	22	15	45	100	1.3	3.0	5	3000	6-7,9-10	A								

TYPE 32Z - SMD DUAL TRANSFORMER

ISDN S-Interface

FEATURES

- Designed to meet FCC and CCITT I.430.
- Meets UL 1459 and UL1950.
- Designed for vapor phase and IR reflow soldering.
- Dielectric test voltage: 2000 Vrms MIN.

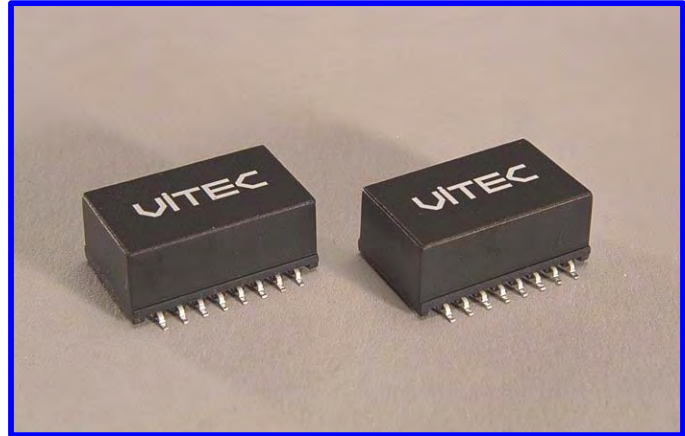

PACKAGE

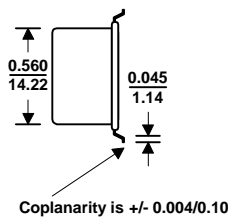
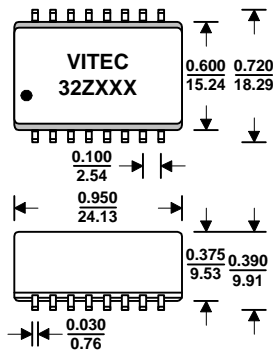

Drawing NOT to scales. Dimensions Inches/mm +/- 0.01* Unless noted.

SCHEMATIC

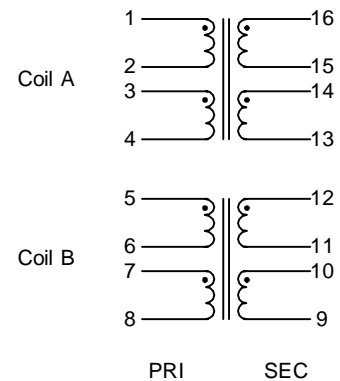

ELECTRICAL CHARACTERISTICS @ 25°C

Part Number	Turns Ratio		LP	Pri/Sec LL		Pri/Sec Cc	Pri CD		Pri DCR		Sec DCR		Idc
	A	B	mH	μH		pF	pF		Ohm		Ohm		mA
			MIN	MAX		MAX	MAX		+/- 25%		+/- 25%		MAX
	+/- 5%		A & B	A	B	A & B	A	B	A	B	A	B	A/B
32Z2412	1:1	1:2	22	5	15	100	42	80	2.4	2.3	2.4	4.0	1
32Z2413	1:1	1:1	22	5	5	100	42	42	2.4	2.4	2.4	2.4	1
32Z2415	1:2	1:2	22	15	15	100	80	80	2.5	2.5	4.3	4.3	1
32Z2418	1:2.5	1:2.5	22	5-40	5-40	100	110	110	2.5	2.5	5.8	5.8	1
32Z2419	1:2	1:2	22	11	11	100	180	180	2.4	2.4	4.4	4.4	1

TYPE 32Z - LOW PROFILE SMD DUAL TRANSFORMERS

ISDN S-Interface

FEATURES

- Designed to meet FCC and CCITT I.430.
- Excellent longitudinal balance.
- Meet UL 1459 and UL 1950.
- Dielectric test voltage: 2000 Vrms MIN.
- Operating temperature: 0 to +70°C.

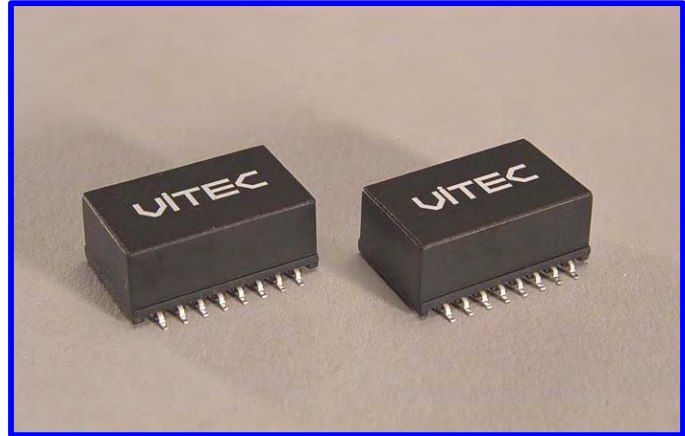

PACKAGE

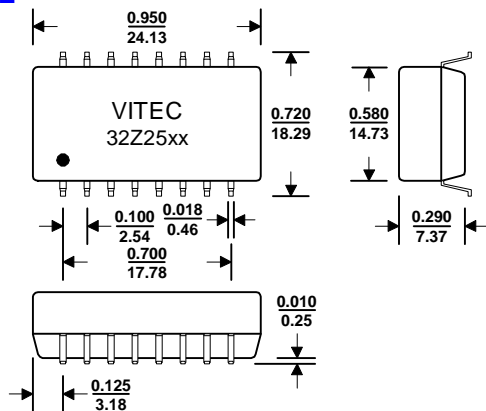

Drawing NOT to scales. Dimensions Inches/mm +/- 0.01" Unless noted

SCHEMATIC

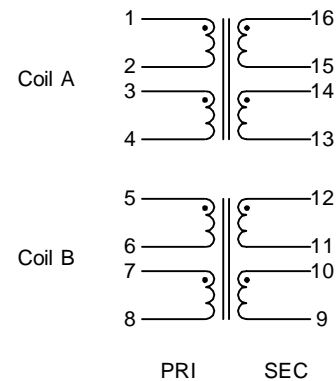

ELECTRICAL CHARACTERISTICS @ 25°C

Part Number	Turns Ratio		OCL	Sec L _L		C _c	Pri CD		Pri DCR		Sec DCR		I _{bc}
	+/- 2%		mH	µH		pF	pF		Ohm		Ohm		mA
	A	B	MIN	A	B	MAX	A	B	B	A	A	B	MAX
32Z2505	1:2.5	1:2.5	22	40	40	100	110	110	2.4	2.4	5.3	5.3	1
32Z2506	1:2	1:2	22	11	11	100	180	180	2.4	2.4	4.4	4.4	1
32Z2507	1:2	1:2	22	5	5	85	80	80	2.4	2.4	4.2	4.2	1
32Z2508	1:1	1:1	22	5	5	100	42	42	2.4	2.4	2.4	2.4	1
32Z2509	1:1	1:2	22	4	5	100	42	80	2.4	2.4	2.4	4.2	1
32Z2510	1:1.8	1:1.8	22	15	15	100	160	160	2.4	2.4	3.8	3.8	1

Transformer Selection Guide

IC Manufacturer	IC Part Number	Part Number
AMD	Am79C30A / Am79C32A	32Z2506
AT&T/Lucent	T7250 / T7256 / T7259 T7903	32Z2505 32Z2507
Mietec	MTC-2072	32Z2507
Mitel	MT8930	32Z2507
Motorola	MC145474 / MC145475 MC145574	32Z2508 32Z2505
National	TP3420/3421	32Z2507
SGS Thomson	ST5420, ST5421	32Z2507
Siemens	PEB2080/2081/2085, PSB2186, PEB2084/2086	32Z2507
Yamaha	7405B, YTD421	32Z2507
Intel	29C53	32Z2510

Notes:

INTERFACE TRANSFORMERS

64 KBPS, DDS

FEATURES

- Designed for 64 Kbps, Switched 56, DDS telecom applications.
- Custom designs available.
- SMD packages available.
- Designed to interface Level One LXT-400, LXT-441, and other IC manufacturers.

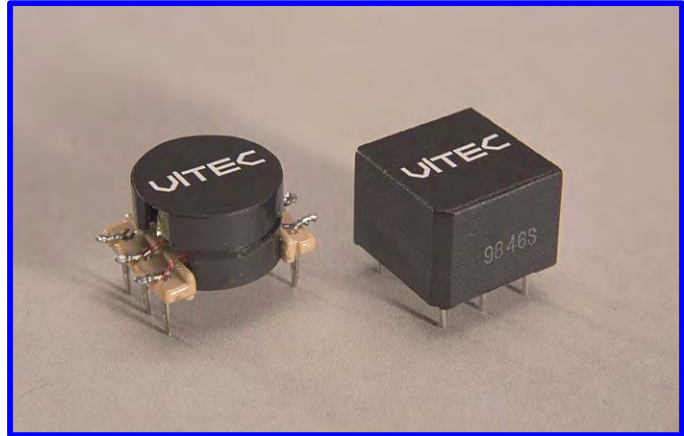

PACKAGE 1	PACKAGE 2	PACKAGE 3
Dimensions Inches/mm +/- 0.01" Unless noted	Dimensions Inches/mm +/- 0.01" Unless noted	Dimensions Inches/mm +/- 0.01" Unless noted

SCHEMATICS

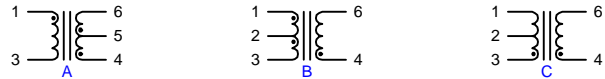

ELECTRICAL CHARACTERISTICS @ 25°C

64 KBPS Isolation Transformer

Part Number	Turns Ratio	OCL	Pri/Sec LL	Pri/Sec CC	Primary DCR	Secondary DCR	Package & Schematic
		mH	uH	pF	Ohm	Ohm	
		MIN	MAX	MAX	MAX	MAX	
18Z4845	1:2CT	7.5	5.0	130	2.0	4.0	1A
18Z4846	1CT:1	10.0	5.0	100	2.6	2.6	1B

DDS Switched 56

Part Number	Turns Ratio	OCL*	Pri/Sec LL	Pri/Sec CC	Pri/Sec DCR	Line Impedance	Insertion Loss*	Return Loss vs Line Z	Dielectric Test	Frequency Response	Longitudinal Balance		DC Bias Current	Package & Schem.
		mH	uH	pF	Ohm	Ohm	dB	dB	VAC	dB	dB	dB	mA	
		MIN	MAX	MAX	TYP	TYP	MAX	@ 1 KHz	MAX	100Hz to 112KHz	200Hz-1KHz	15KHz-2MHz	MAX	
33Z3815	1:1	200	43	50	17.80	135	1.50	32	1500	+/- 1.0	60	40	50	2C
33Z3818	1CT:1	15	40	50	4.50	135	1.50	32	1500	+/- 1.0	60	40	50	3C

Notes: * 1 KHz at 1 Volt

ISOLATION TRANSFORMERS

ISDN-U Interface

FEATURES

- Designed for ISDN-U telecom applications.
- Product matched to most IC manufacturers.
- Designed to meet or exceed ANSI T1.601-1992.
- Standard 10 pin SMD or THT packages.
- Dielectric test voltage: 2000 Vrms MIN.

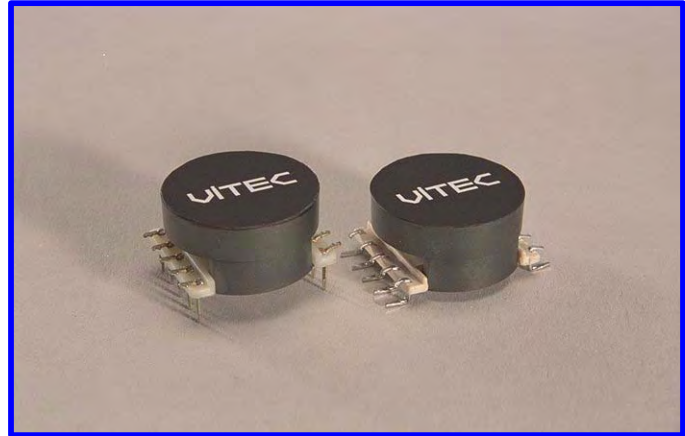

PACKAGE (THT)

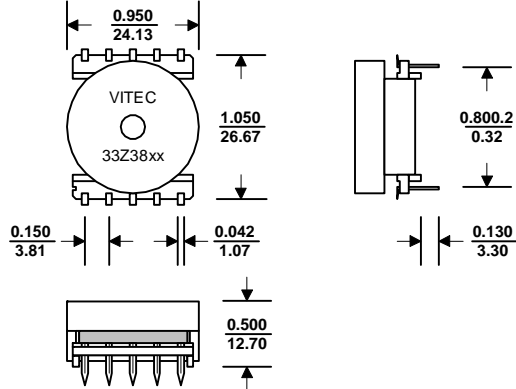

Drawing NOT to Scale. Dimensions Inches/mm. +/- 0.005/0.127 Unless noted.

PACKAGE (SMD)

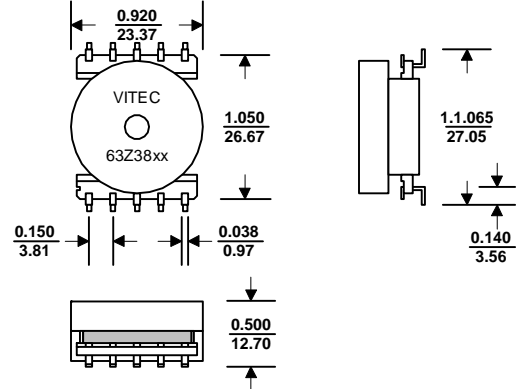

Drawing NOT to Scale. Dimensions Inches/mm. +/- 0.005/0.127 Unless noted.

SCHEMATIC A

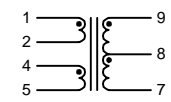

SCHEMATIC B

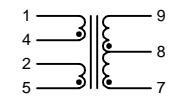

ELECTRICAL CHARACTERISTICS @ 25°C

Part Number & Schematic			Turns Ratio	OCL Line Side	DCR Line Side	DCR Chip Side	IDC	Return Loss	Longitudinal Balance		Dielectric Test	Line Side Pins
									LINE : cHIP	mH		
THT	SMD	Type	+/- 3%	NOM	MAX	MAX	NOM	MIN	@281Hz to 40KHz	@ > 40KHz	MIN	
33Z3879	63Z6379	A	2.00:1	25.5-28.5	11.6	6.4	60	20	55	-20/decade	2000	1-5
33Z3880	63Z6380	B	1.50:1	14.2-15.8	16.0	2.5	60	20	55	-20/decade	2000	4-2
33Z3881	63Z6381	B	1.50:1	25.6-29.0	20.0	3.0	60	20	55	-20/decade	2000	4-2
33Z3882	63Z6382	A	1.50:1	25.6-29.0	20.0	3.0	60	20	55	-20/decade	2000	1-5
33Z3883	63Z6383	A	1.25:1	26.5-29.5	12.0	7.0	80	20	55	-20/decade	2000	1-5

Transformer Selection Guide

IC Manufacturer	IC Part Number	Coding	THT	SMD
Motorola	MC145472	2B1Q	33Z3879	63Z6379
	MC145572	2B1Q	33Z3883	63Z6383
National	TP3410	2B1Q	33Z3881	63Z6381
		2B1Q	33Z3882	63Z6382
Thompson	SD5411	2B1Q	33Z3880	63Z6380

Notes:

TYPE 33Z - ISOLATION TRANSFORMERS

ISDN-U Interface

FEATURES

- Designed for 2B1Q and 4B3T ISDN-U telecom applications
- Printed circuit board mounting.
- Meets ANSI T1.601:1992.
- Matched to major chipsets.

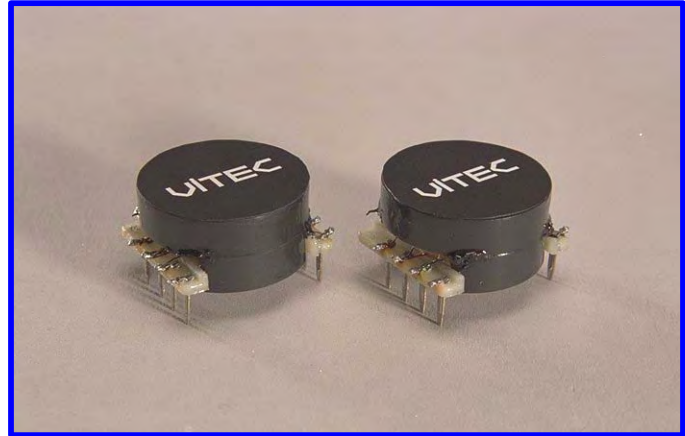

PACKAGE

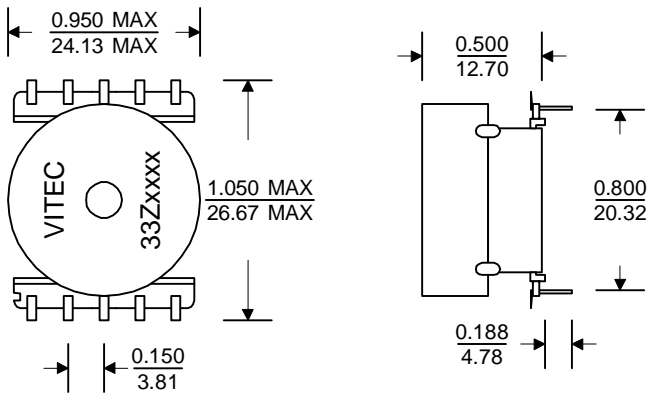

Drawing NOT to scale. Dimensions Inches/mm +/- 0.01" Unless noted

SCHEMATIC A

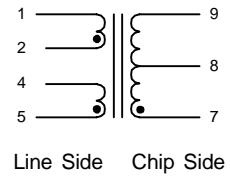

SCHEMATIC B

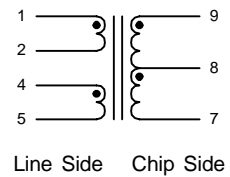

ELECTRICAL CHARACTERISTICS @ 25°C

Part Number	Turns Ratio +/- 3%	OCL Line Side	DCR Line Side	DCR Chip Side	IDC	Dielectric Strength Vrms MIN	Schematic	Line Side Pins
		mH NOM	Ohms MAX	Ohms MAX				
33Z3913	1.50:1	25.6-29.0	20.0	3.0	60	2500	A	4-2
33Z3914	1.50:1	25.6-28.4	20.0	3.0	60	2500	B	1-5
33Z3915*	1.25:1	26.5-29.5	13.0	7.5	80	2500	B	1-5

Notes: * Operating temperature range: -40°C to 85°C.

TYPE 33Z - SMALL PACKAGE TRANSFORMERS

ISDN-U Interface

FEATURES

- Designed for 2B1Q and 4B3T ISDN-U telecom applications
- Printed circuit board mounting.
- Meets ANSI T1.601:1992.
- Designed for Motorola MC 145572.

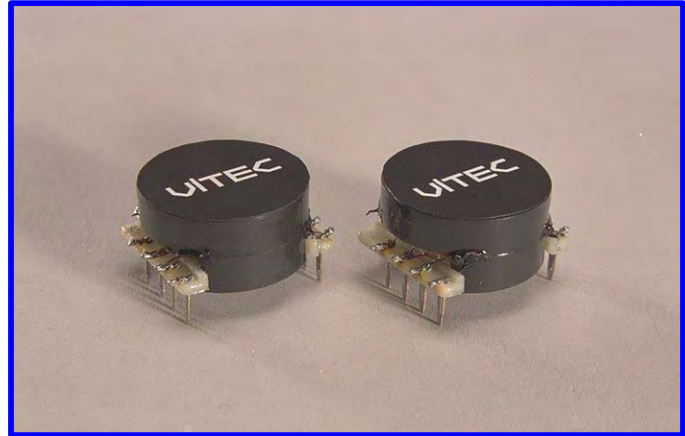

PACKAGE

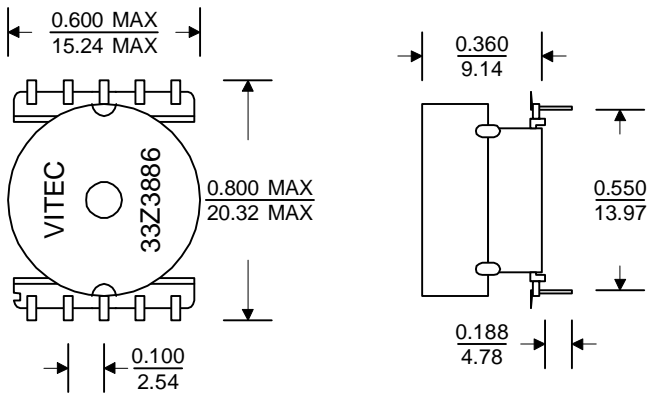

Drawing NOT to scale. Dimensions Inches/mm +/- 0.01" Unless noted

33Z3886

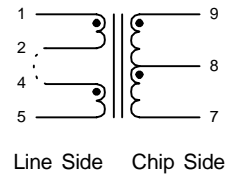

33Z3886G

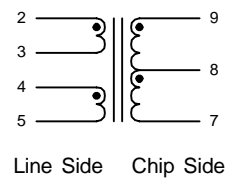

ELECTRICAL CHARACTERISTICS @ 25°C

Part Number	Turns Ratio +/- 3%	OCL	DCR	DCR	IDC	Return Loss ⁽²⁾	Longitudinal Balance		LL	Dielectric Test	Line Side Pins
		Line Side	Line Side	Chip Side			dB				
		mH NOM	Ohms MAX	Ohms MAX			mA NOM	dB MIN			
33Z3886 ⁽¹⁾	1.25:1	25.0-31.0	12.0	9.0	20	20	55 ⁽³⁾	-20/ decade ⁽⁴⁾	150 ⁽⁵⁾	2000	1-5
33Z3886G	1.25:1	26.5-29.5	16.0	13.0	20	20	55 ⁽³⁾	-20/ decade ⁽⁴⁾	--	1500	2-5

- Notes:**
- (1) Not suitable for applications requiring a DC bias.
 - (2) Tested at 10 & 25 KHz.
 - (3) Tested at 281 Hz to 40 KHz.
 - (4) Tested at above 40 KHz.
 - (5) Tested 1-5 with 7-9 shorted.

ISOLATION TRANSFORMERS

ISDN-U Interface

FEATURES

- Designed for ISDN-U telecom applications.
- Product matched to most IC manufacturers.
- Designed to meet or exceed ANSI T1.601-1992.
- Standard 10 pin SMD or THT packages.
- Dielectric test voltage: 2000 Vrms MIN.

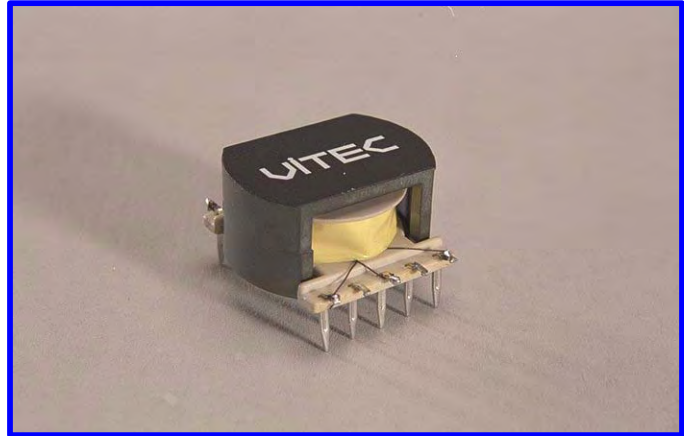

PACKAGE 1

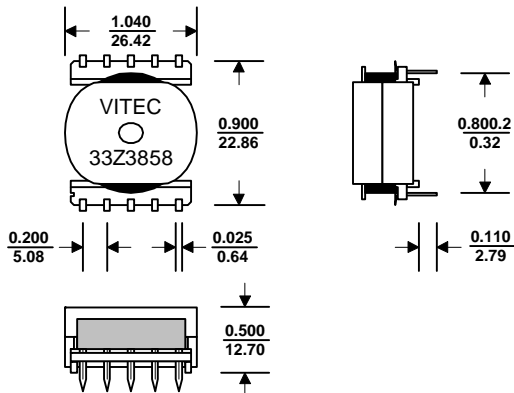

Drawing NOT to scale. Dimensions Inches/mm. +/- 0.005/0.127 Unless noted.

PACKAGE 2

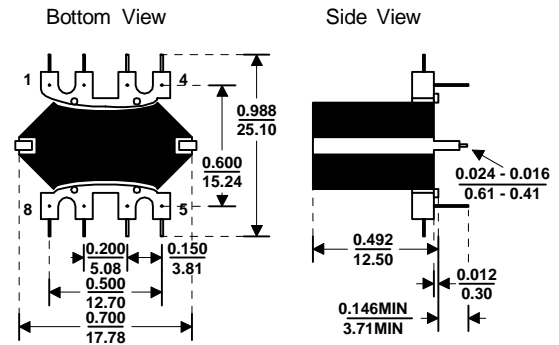
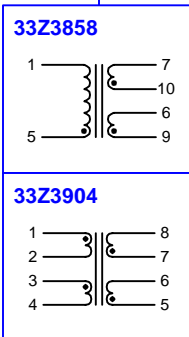

Drawing NOT to scale. Dimensions Inches/mm. +/- 0.005/0.127 Unless noted.

ELECTRICAL CHARACTERISTICS @ 25°C

Part Number	Turns Ratio	ACL	Pri DCR	Sec DCR	IDC	Return Loss	Longitudinal Balance		Dielectric Test	Linearity
		mH	Ohms	Ohms	mA	dB @ 10&25 KHz	dB MIN		Vrms	dB MIN
		NOM	+/- 20%	+/- 20%	MAX	MIN	@281Hz to 40KHz	@ > 40KHz	MIN	@500Hz - 1.5KHz
33Z3858	1.50:1	73-98	13.00	6.50	40	20	55	-20/decade	2000	55
33Z3904	1.32:1.32:1:1	6.2-7.6	2.25	1.70	60	--	--	--	2000	--

Transformer Selection Guide

IC Manufacturer	IC Part Number	Part Number
Lucent	T7234	33Z3858
	T7237	33Z3858
	T7256	33Z3858
	T7264	33Z3858
Siemens	2090	33Z3904

Notes:

TYPE 33Z - INTERFACE TRANSFORMERS

ISDN-U

FEATURES

- Designed for 2B1Q and 4B3T ISDN-U telecom applications.
- Matched to most IC manufacturers.
- Meets ANSI T1.601:1992.
- Printed circuit board mounting.
- 2000 Vrms isolation.

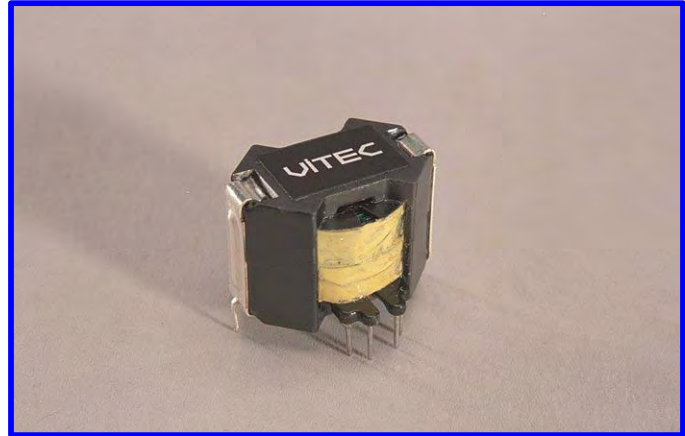

PACKAGE

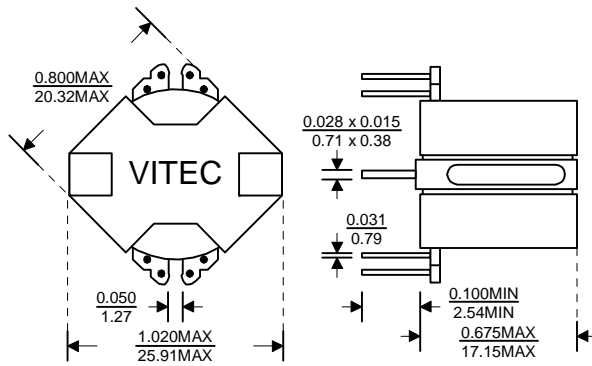

Drawing NOT to scale. Dimensions Inches/mm +/- 0.01" Unless noted

33Z3901

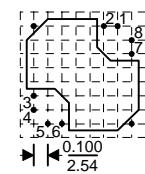
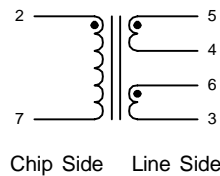

33Z3908

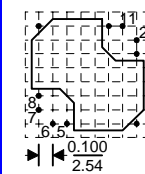
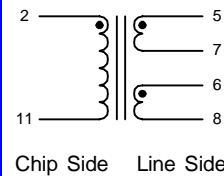

33Z3909

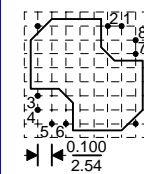
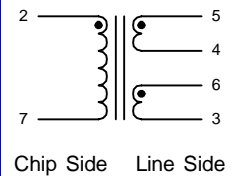

ELECTRICAL CHARACTERISTICS @ 25°C

Part Number	Turns Ratio	LP	DCR Line Side	DCR Chip Side	LL	CC	Longitudinal Balance		IDC	Dielectric Test	Line Side Pins						
							mH	Ohms				Ohms	uH	pF	dB	mA	Vrms
33Z3901	1:1:1.5	50.0	12.40	6.85	160	150	--	--	150	2000	3-5						
33Z3908	1:1.5	14.5	4.40	3.50	55	80	65 ⁽¹⁾	58 ⁽²⁾	50	2000	5-8						
33Z3909	1.5:1	50.0	12.40	6.85	160	--	--	--	150	2000	3-5						

Transformer Selection Guide

IC Manufacturer	IC Part Number	Part Number
AT&T	T7256	33Z3909
	T7264	33Z3909
Siemens	PEB 2091	33Z3901
		33Z3908
		33Z3909

Notes: (1) Tested at 1-4 KHz.
(2) Tested at 4-160 KHz.

INTERFACE TRANSFORMERS

ISDN-Upo, ISDN-Upn and ISDN-S

FEATURES

- Products matched to Siemens transceiver chips.
- Both SMD and Through Hole packages available.
- Common footprints & pinouts.
- Low cost

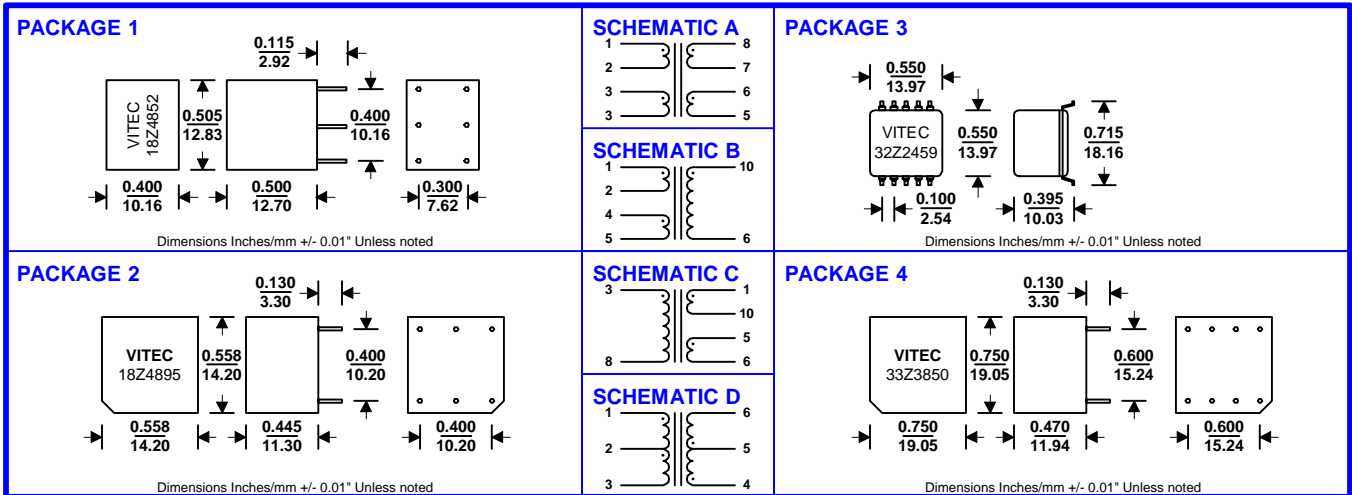
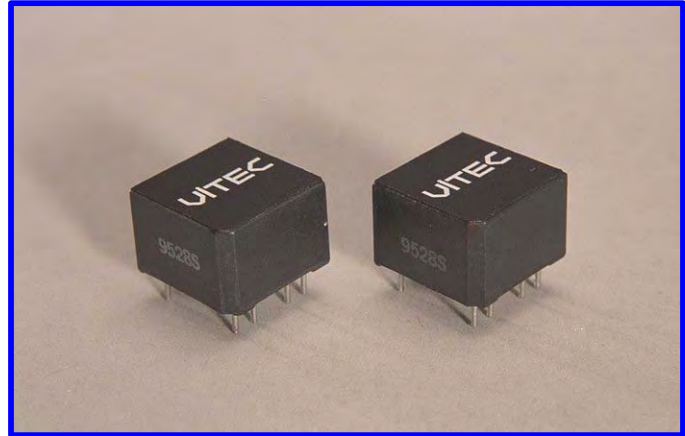

ELECTRICAL CHARACTERISTICS @ +25°C

Part Number	Turns Ratio	Induct.	Current	Pri DCR	Sec DCR	Isolation	Type	Mounting	Primary Pins	Package/Schematic					
	Ratio										mH	DC	Ohms	Ohms	Vrms
	+/- 5%										MIN	MAX	MIN	MAX	MIN
ISDN Upo and ISDN Upn Transformers															
33Z3850	1.25SCT:1SCT	4.2 +/-10%	80	2.9	2.4	1500	Single Xfmr	THT	1-4	4/A					
32Z2459	1SCT:1.25	1.7	60	1.6	2.4	1500	Single Xfmr	SMT	1-5	3/B					
ISDN S Transformers															
18Z4852	1SCT:2	22	1	2.5 +/-25%	5.0 +/-25%	2000	Single Xfmr	THT-Vert	1-6	1/C					
18Z4895	1CT:2CT	22	1	2.5 +/-25%	4.6 +/-25%	1500	Single Xfmr	THT	1-3	2/D					

HDSL TRANSFORMERS

SELECTION GUIDE

IC Manufacturer	IC P/N	Application	Vitec P/N	
			THT	SMD
Alcatel	MTK-20131	CPE	33Z3830	--
	MTK-20140	CPE	--	60Z924
	MTK-20140	CO	--	70Z7124
Analog Device	AD20910/918	CO/CPE	70P7118	60P918
	AD20910/918	--	70Z7128	60P928
	AD8042	784/1168 Kbps	70Z7240	--
Burr Brown	AFE1124	784 Kbps	70Z7238	--
	AFE1124	1168 Kbps	70Z7237	--
Conexant/Brooktree	BT8921	784 Kbps (2 pairs)	33Z3823	63Z6323
	BT8921	784 Kbps (2 pairs)	70Z7251	60Z851
	BT8921	1168 Kbps (2 pairs)	33Z3824	63Z6324
	BT8921	1168 Kbps (2 pairs)	70Z7250	60Z850G
	BT8952	784 Kbps (2 pairs)	33Z3816	63Z6316
	BT8952	1168 Kbps (2 pairs)	33Z3817	63Z6317
	BT8952	784 Kbps (2 pairs)	70Z7288	60Z888
	BT8952	1168 Kbps (2 pairs)	70Z7287	call factory
	BT8960	160 Kbps	33Z3827	63Z6327
	BT8960	288 Kbps	33Z3826	63Z6326
	BT8960	360 Kbps	70Z7255	call factory
	BT8960	416 Kbps	33Z3825	63Z6325
	BT8960	576 Kbps	70Z7256	call factory
	BT8970	400 Kbps	70Z7222	call factory
	BT8970	528 Kbps	70Z7223	call factory
	BT8970	784 Kbps (2 pairs)	33Z3823	63Z6323
	BT8970	784 Kbps (2 pairs)	70Z7251	60Z851
BT8970	1168 Kbps (2 pairs)	33Z3824	63Z6324	
BT8970	1168 Kbps (2 pairs)	70Z7250	60Z850	
Globespan	--	784/1168 Kbps	call factory	call factory
Level One	SK70704 / SK70707	784 Kbps (2 pairs)	33Z3821	63Z6321
	SK70704 / SK70707	1168 Kbps (2 pairs)	33Z3822	63Z6322
	SK70720 / SK70721	568 Kbps	70Z7249	call factory
	SK70740 / 41 / 42	1168 Kbps (2 pairs)	33Z3839	63Z6339
Metalink	Mt"xx40B Series	All rates	call factory	call factory
	Mt"xx40B Series	784/1168 Kbps	call factory	call factory

Please contact the factory for other selections not listed on this page.

ISOLATION TRANSFORMERS

HDSL Interface

FEATURES

- Designed for HDSL telecom applications.
- Products matched to leading transceiver ICs.
- Designed to meet ANSI and ETSI standards.
- Dielectric test voltage: 1500 Vrms minimum.
- SMD and THT packages available.

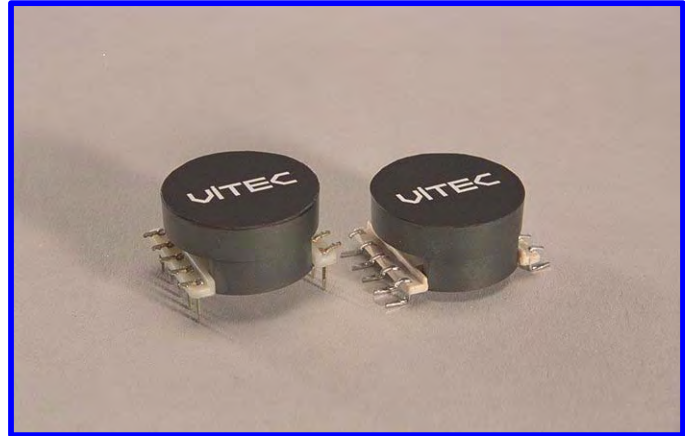

PACKAGE (THT)

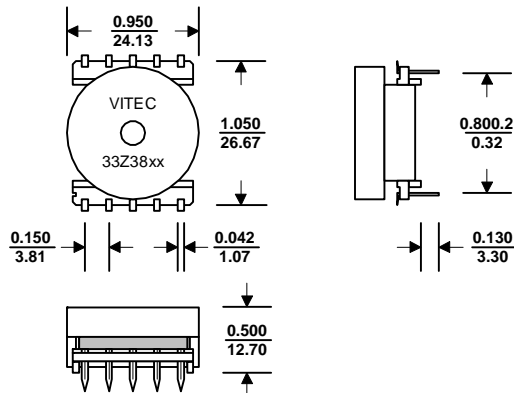

Drawing NOT to Scale. Dimensions Inches/mm. +/- 0.005/0.127 Unless noted.

PACKAGE (SMD)

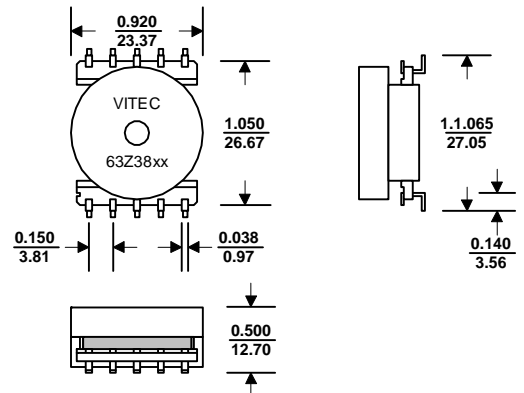
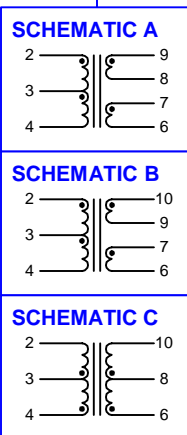

Drawing NOT to Scale. Dimensions Inches/mm. +/- 0.005/0.127 Unless noted.

ELECTRICAL CHARACTERISTICS @ 25°C

Part Number & Schematic	Turns Ratio	OCL Line Side	DC (I) Capability	LL	Dielectric Strength	DCR Line side	DCR Chip side	Return Loss			Longitudinal Balance @135 Ohm	THD ⁽⁴⁾ @135 Ohm		
								Chip Side	mH	mA			uH	Vrms
THT	SMD	Type	+/- 3%	NOM	NOM	MAX	MIN	MAX	MAX	4 KHz-2 MHz	40-200 KHz	40-320 KHz	TYP	TYP
33Z3816	63Z6316	A	2CT:1:1	3.00 +/-6%	160	16	1500	2.2 (6-7),(8-9)	4.4	4	20	--	55 @196KHz	-75 @200KHz
33Z3817	63Z6317	A	2CT:1:1	2.00 +/-6%	160	16	1500	2.2 (6-7),(8-9)	4.4	4	--	16.5	55 @292KHz	-75 @200KHz
33Z3821	63Z6321	C	1CT:1.8CT	2.75 +/-6%	75	--	2000	3.0	3.2	--	20	--	50 @5-196KHz	-75 @5KHz
33Z3822	63Z6322	B	1CT:1.8SCT	2.06 +/-6%	75	--	2500	2.0	2.0	--	--	16.5	50 @5-196KHz	-75 @5KHz
33Z3823	63Z6323	A	1CT:1:1	3.00 +/-6%	70	8	1500	2.2 (6-7),(8-9)	2.2	4	20	--	55 @196KHz	-75 @200KHz
33Z3824	63Z6324	A	1CT:1:1	2.00 +/-6%	70	8	1500	2.2 (6-7),(8-9)	2.2	4	--	16.5	55 @292KHz	-75 @200KHz
33Z3825	63Z6325	A	1CT:1:1	3.50 +/-10%	70	12	1500	2.2	2.2	--	--	16.5 ⁽³⁾	55 @104KHz	-70 @104KHz
33Z3826	63Z6326	A	1CT:1:1	5.00 +/-10%	70	12	1500	2.5	2.5	--	16.5 ⁽²⁾	--	55 @72KHz	-70 @80KHz
33Z3827	63Z6327	A	1CT:1:1	8.00 +/-10%	70	16	1500	3.0	3.0	16.5 ⁽¹⁾	--	--	55 @40KHz	-70 @40KHz

Notes: ⁽¹⁾ Tested @ 9-40 KHz
⁽²⁾ Tested @ 20-80 KHz
⁽³⁾ Tested @ 33-110 KHz
⁽⁴⁾ Tested @ 6V p-p

TRANSFORMERS IN SMD OR THT PACKAGES

HDSL and POTS Splitters Applications

FEATURES

- Designed for digital telecom applications.
- Product matched to leading transceiver ICs.
- Standard 10 pin SMD or THT packages.
- Designed to exceed ANSI and ETSI standards.
- Excellent total harmonic distortion.
- HDSL transformers recognized to TNV-3 under IEC60950/EN60950.
- Other designs available.

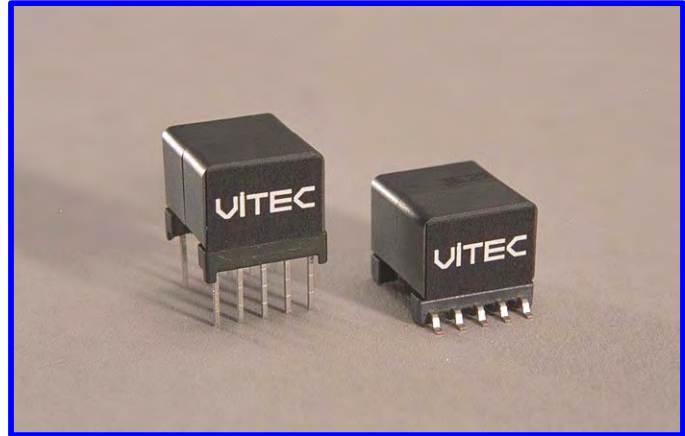

<p>70Z7xxx</p> <p>Drawing NOT to Scale. Dimensions Inches/mm. +/- 0.005/0.127 Unless noted.</p>	<p>SCHEMATICS</p> <p>Line Chip</p>	<p>60Zxxx</p> <p>Drawing NOT to Scale. Dimensions Inches/mm. +/- 0.005/0.127 Unless noted.</p>
--	---	---

ELECTRICAL CHARACTERISTICS @ 25°C

Part Number		Turns Ratio	Lp ⁽¹⁾	LL ⁽²⁾	Primary DCR	Secondary DCR	Dielectric Strength	THD	Insertion Loss	Longitudinal Balance	Bias (both windings)	Schem.
SMD	THT	Ratio +/- 1%	mH +/- 10%	uH MAX	Ohms MAX	Ohms MAX	Vrms MIN	dB MIN	dB MAX	dB MIN	ADC	
Coupled Inductor for POT Low Pass Filter												
---	70Z7008	1:1	5.50	12	5.25	5.25	850	--	--	--	0 - 0.080	A
60Z823	70Z7023	1:1	6.00	--	4.40	4.40	1500	--	--	--	0 - 0.060	B
60Z824	70Z7024	1:1	4.00	--	3.60	3.60	1500	--	--	--	0 - 0.100	B
60Z825	70Z7025	1:1	3.00	--	3.00	3.00	1500	--	--	--	0 - 0.100	B
HDSL Transformers												
60Z850	70Z7250	2:1	2.00	11	2.50	1.00	2100	70 dB @ 20KHz	0.5 dB @ 40KHz	50 dB @ 40-300KHz	--	C
60Z872	70Z7272	2.3:1	2.00	35	(1-4/2-5) 2.05/2.05	(6-9) 1.00	1500	-80 dB @ 20KHz	--	55 dB @ 20-560KHz	--	D

Notes: (1) Tested @10KHz, 0.1V
(2) Tested @100KHz, 0.1V

SMD COMMON MODE CHOKES

LAN and Telecom

FEATURES

- Reduces EMI noise in the common mode providing better performance for FCC.
- IEEE 802.3 and IEEE 802.5 compatible.
- SMD packages for pick and place manufacturing.
- Designed for vapor phase and IR reflow soldering.
- Tape and Reel packaging available, please call factory.
- RoHS compliant product available for select packages.

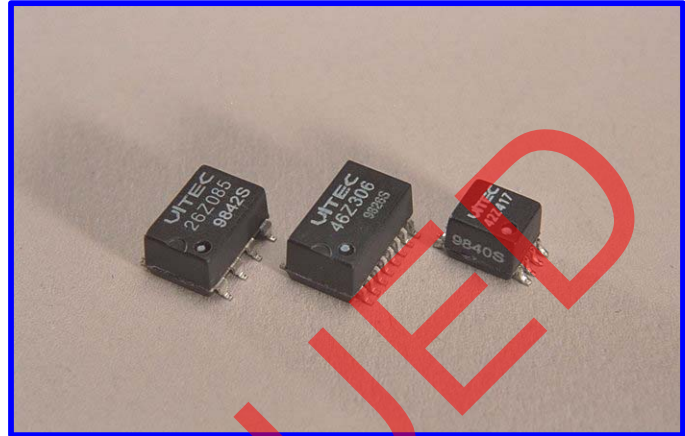

ELECTRICAL CHARACTERISTICS @ 25°C

Part Number		OCL	Common Mode Attenuation					Crosstalk	LL	CC	DCR	Dielectric Strength	Case Style Schematic
			uH	100Khz	10Mhz	50Mhz	100Mhz						
Classic	RoHS	MIN	dB TYP	dB TYP	dB TYP	dB TYP	dB TYP	0-25 MHz	uH	pF	Ohms	Vrms	
								dB MAX	MAX	MAX	MAX	MIN	
26Z085	26ZR085	36.0	--	--	--	--	--	45	0.30	25	0.35	500	4E
26Z091	26ZR091	24.0	--	15	--	20	--	--	0.20	15	0.20	500	4I
28Z550	28ZR550	22.5	7	30	38	34	24	--	--	--	0.22	--	3H
28Z551	28ZR551	100.0	14	44	49	44	34	--	--	--	0.60	--	3E
42Z417	42ZR417	68	1	22	21	19	18	--	0.20	15	0.20	500	2I
46Z151	N/A	40.0	7	35	37	32	21	--	0.30	25	0.20	500	1G
46Z157	N/A	67.0	9	31	29	27	21	--	--	--	0.20	--	1F
46Z238	Call Factory	37.0	8	28	28	27	25	--	--	--	0.30	--	5C
46Z259	Call Factory	85.0	8	30	27	24	16	--	0.25	--	0.20	500	5D
46Z306	46ZR306	85.0	8	29	30	29	24	--	0.25	--	0.20	500	5B
46Z309	Call Factory	21.0	6	28	35	36	34	--	--	--	0.35	--	5B
46Z408	Call Factory	36.0	8	36	35	29	18	--	--	--	0.35	--	5A

SMD COMMON MODE CHOKES

LAN and Telecom

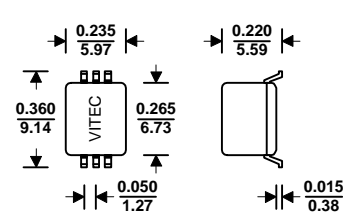
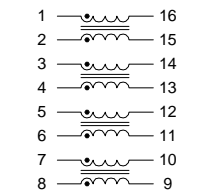
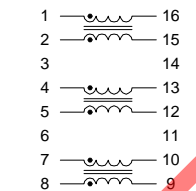
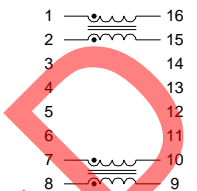
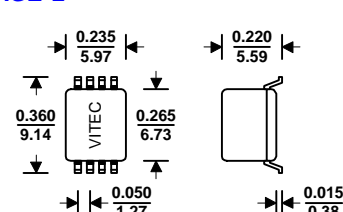
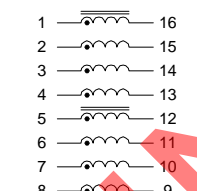
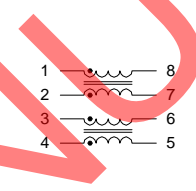
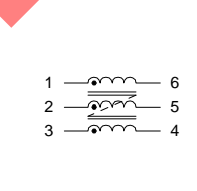
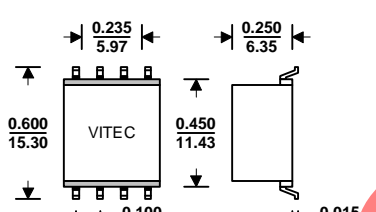
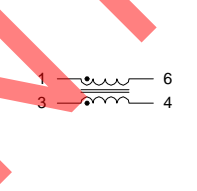
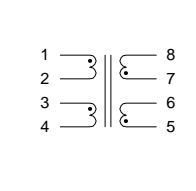
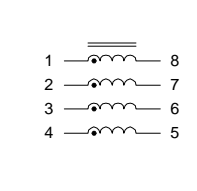
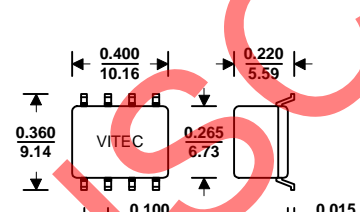
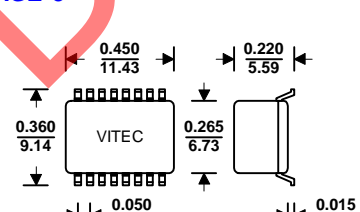
<p>PACKAGE 1</p> 	<p>SCHEMATIC A</p> 	<p>SCHEMATIC B</p> 	<p>SCHEMATIC C</p> 
<p>PACKAGE 2</p> 	<p>SCHEMATIC D</p> 	<p>SCHEMATIC E</p> 	<p>SCHEMATIC F</p> 
<p>PACKAGE 3</p> 	<p>SCHEMATIC G</p> 	<p>SCHEMATIC H</p> 	<p>SCHEMATIC I</p> 
<p>PACKAGE 4</p> 			
<p>PACKAGE 5</p> 			

COMMON MODE CHOKES - THROUGH HOLE PACKAGES

LAN and Telecom

FEATURES

- Reduces EMI noise in the common mode providing better performance for FCC.
- Designed to meet IEEE 802.3 and IEEE 802.5.
- Frequency range from 100 KHz to 200 MHz.
- Surface mount packages available.
- Low cost.
- RoHS compliant version available.

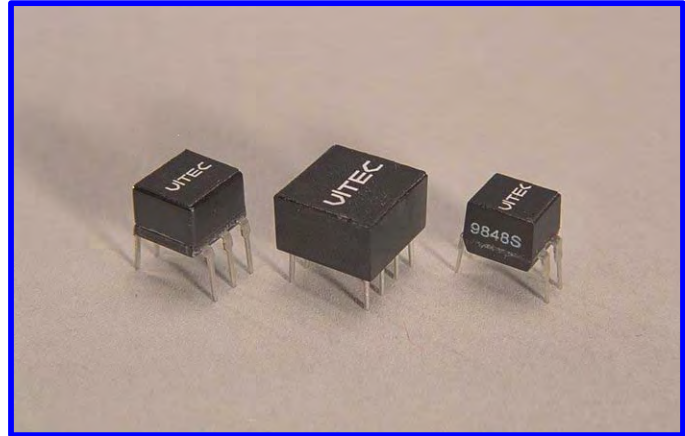

SCHMATIC A	SCHMATIC B	SCHMATIC C	SCHMATIC D	SCHMATIC E	SCHMATIC F
SCHMATIC G	SCHMATIC H	SCHMATIC I	SCHMATIC J	SCHMATIC K	SCHMATIC L

ELECTRICAL CHARACTERISTICS @ 25°C

Part Number		OCL	Common Mode Attenuation					LL	CC	DCR	Dielectric Strength	Package/ Schematic
			uH	100Khz	10Mhz	50Mhz	100Mhz					
Classic	RoHS	MIN	dB TYP	dB TYP	dB TYP	dB TYP	dB TYP	uH	pF	Ohms	Vrms	
14Z3257	14ZR3257	85	8	29	28	26	20	0.25	9.50	0.20	--	8/G
14Z3259	14ZR3259	85	8	29	28	25	17	0.25	9.50	0.20	--	9/C
14Z3267	14ZR3267	85	8	33	30	27	18	0.25	12.00	0.20	--	7/I
14Z3281	14ZR3281	68	--	--	--	--	--	0.25	9.50	0.20	--	10/L
14Z3285	14ZR3285	68	--	--	--	--	--	0.25	12.00	0.20	--	10/K
14Z4506	14ZR4506	85	8	30	28	27	21	0.25	10.00	0.20	--	10/H
16Z5751	16ZR5751	24	1	28	33	28	13	--	--	0.30	--	1/J
18Z4814	18ZR4814	50	14	45	50	47	20	--	--	0.30	--	4/E
18Z4815	18ZR4815	68	7	37	42	40	31	--	--	0.35	--	3/E
18Z4836	18ZR4836	140	14	45	50	47	38	--	--	0.60	--	6/F
18Z4837	18ZR4837	140	14	44	48	43	33	--	--	0.60	--	4/E
18Z4844	18ZR4844	40	14	40	40	35	35	0.15	3.80	0.40	500	3/C
18Z4853	18ZR4853	1000	28	42	22	--	--	--	--	0.70	--	2/B
18Z4854	18ZR4854	4700+/-30%	40	37	23	20	--	--	--	1.00	--	2/B
18Z4855	18ZR4855	6000	44	33	29	--	--	--	--	1.40	--	2/B
24Z4681	24ZR4681	24	--	32	39	34	24	0.20	15.00	0.30	500	3/C
24Z4683	24ZR4683	25	6	32	37	32	21	0.20	15.00	0.35	500	5/A
24Z4685	24ZR4685	24	--	--	--	--	--	0.20	15.00	0.21	U	11/K
24Z4687	24ZR4687	36	--	--	--	--	--	0.30	25.00	0.35	500	3/C

Add an "R" to the part number after "Z" for the RoHS compliant version (i.e. 14ZR3257 is the RoHS compliant version of 14Z3257).

COMMON MODE CHOKES - THROUGH HOLE PACKAGES

LAN and Telecom

PACKAGE 1

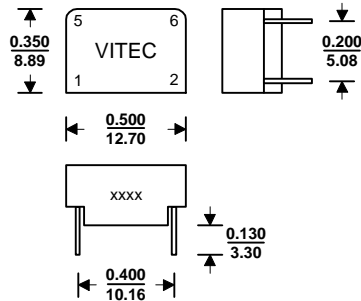

PACKAGE 2

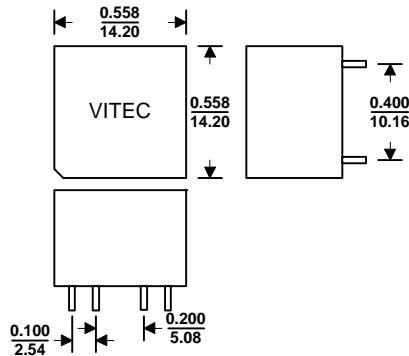

PACKAGE 3

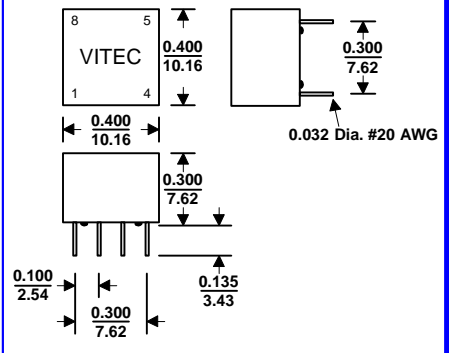

PACKAGE 4

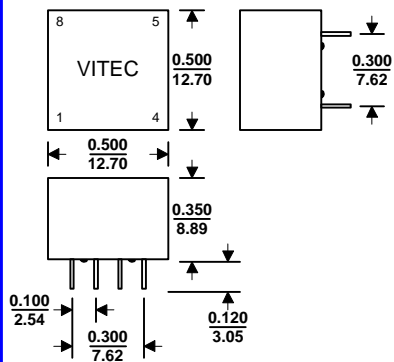

PACKAGE 5

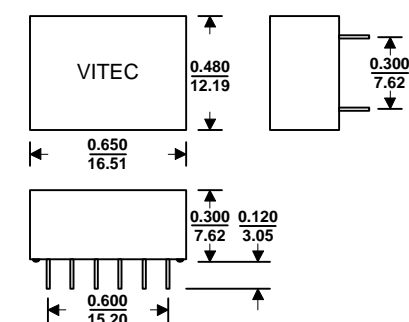

PACKAGE 6

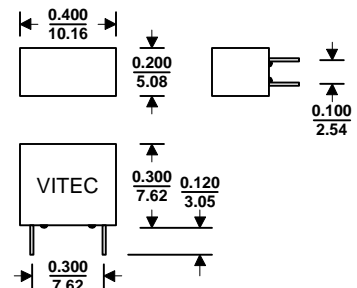

PACKAGE 7

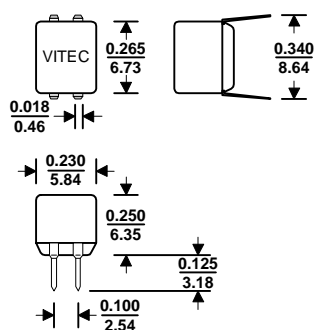

PACKAGE 8

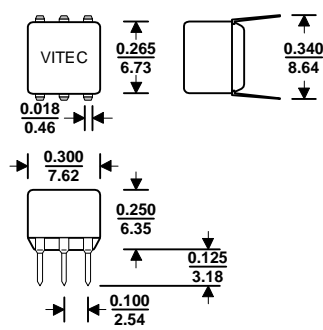

PACKAGE 9

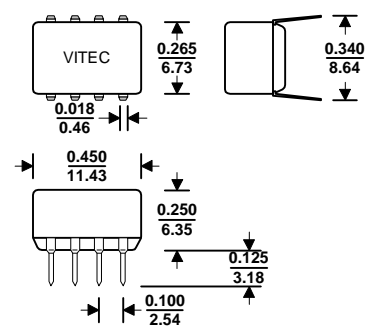

PACKAGE 10

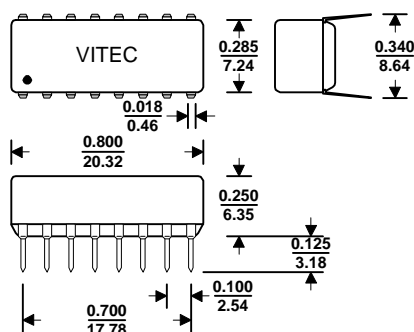

PACKAGE 11

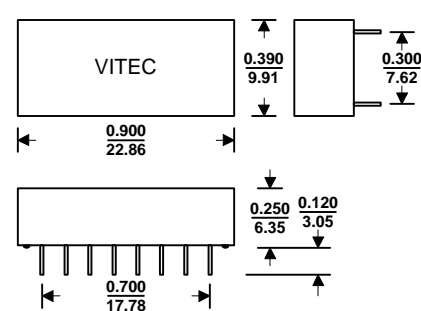

Notes:

ABOUT VITEC ELECTRONICS CORPORATION

Vitec Electronics Corporation was formed in January 1986, after the acquisition of the 11Z Trigate® Pulse Transformer product line from the Magnetic Components Division of the Sprague Electric Company.

Vitec has expanded its product offering to include Pulse and Isolation Transformers, Switching Power Supply Magnetics, Transformers for Local Area Networks (LAN), Telecommunications applications, and Custom Products.

Vitec has a diverse manufacturing capability at it's disposal. Products are manufactured at Fremont, CA. (Headquarters) and mainland China. We are committed to both JIT and Dock-to-Stock programs.

Vitec is committed to develop, manufacture, and market quality products at competitive prices. Our Engineering, Sales, and Customer Service staff is dedicated to customer needs.

As a progressive company, Vitec Electronics Corporation will continuously strive to assure product quality and reliability through material management, product design, application engineering, and quality manufacturing.

OUR COMMITMENT

VITEC Electronics empowers each of its employees by providing a business environment that encourages a commitment to excellence, a sense of ownership and personal accountability to all Vitec Customers.

Competitive Pricing, Quality Products, and On Time Deliveries are expected from today's World Class Magnetics Suppliers.

The high standards of today's customer are strengthening the dedication and commitment of VITEC Electronics to provide Total Customer Service.

INDUSTRIES

- Monitoring
- Metering
- Computing
- Industrial
- Telecom
- Power Protection
- Consumer
- Medical
- Networking
- Audio/Visual
- Test & Measurement
- Automation

PRODUCTS/SYSTEMS

- Power Meters
- Power Distribution
- Test Equipment
- HVAC
- Motion Control
- PCs
- Welders
- Back-up
- UPS
- Laptops
- PDAs
- Appliances
- Scanners
- Heat Exchange
- Security Systems

Half-Bridge Converter Applications

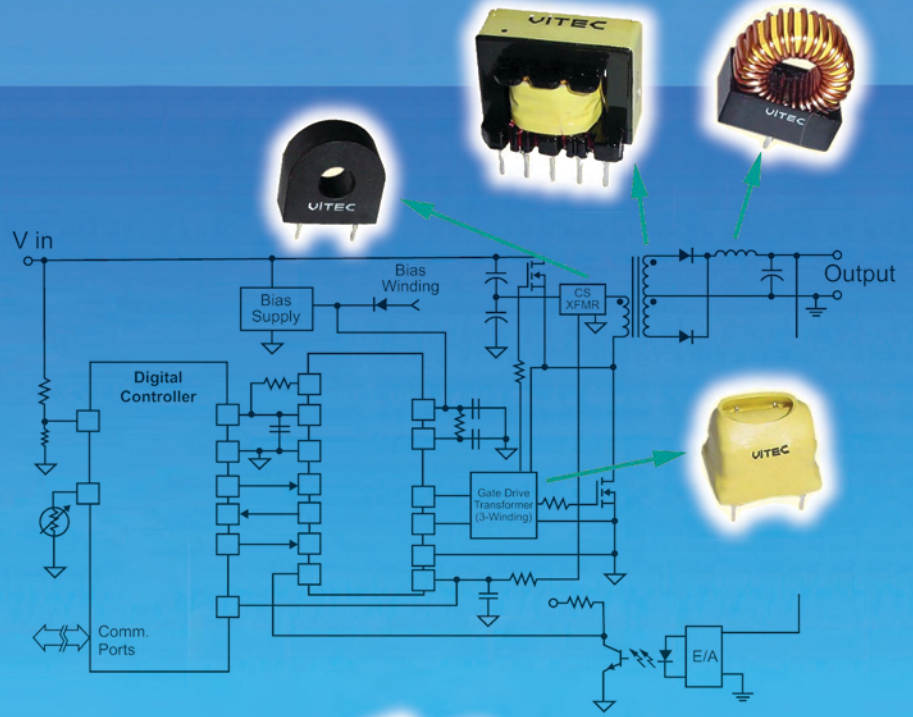

Multi-Phase PWM Applications

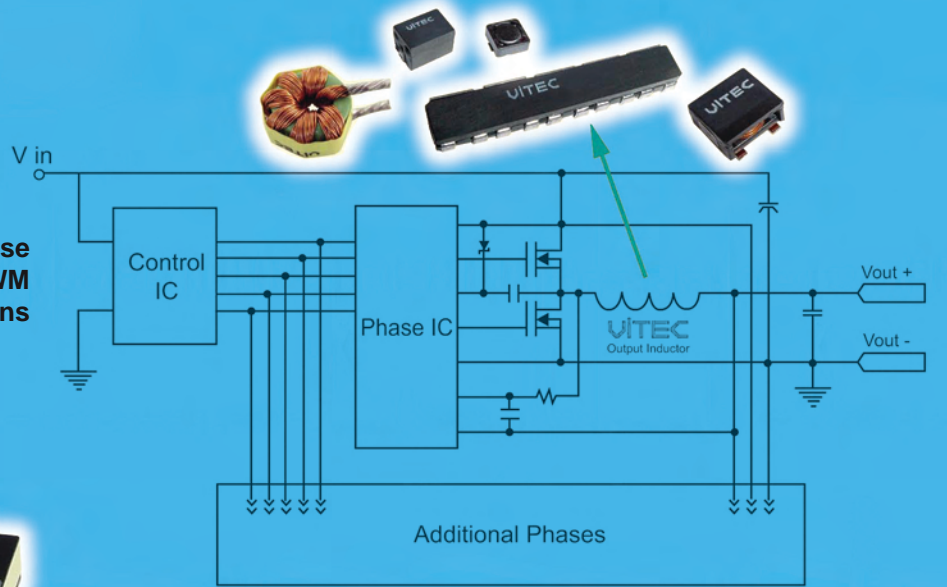

Power Supply Applications

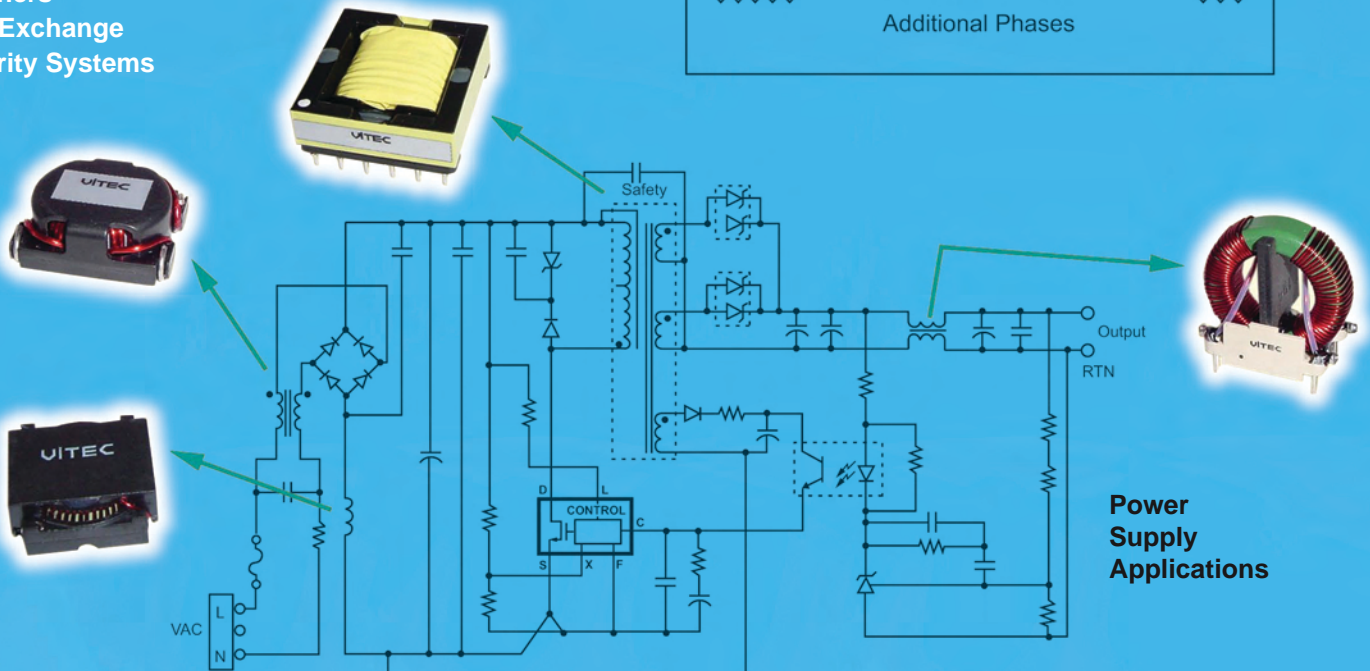

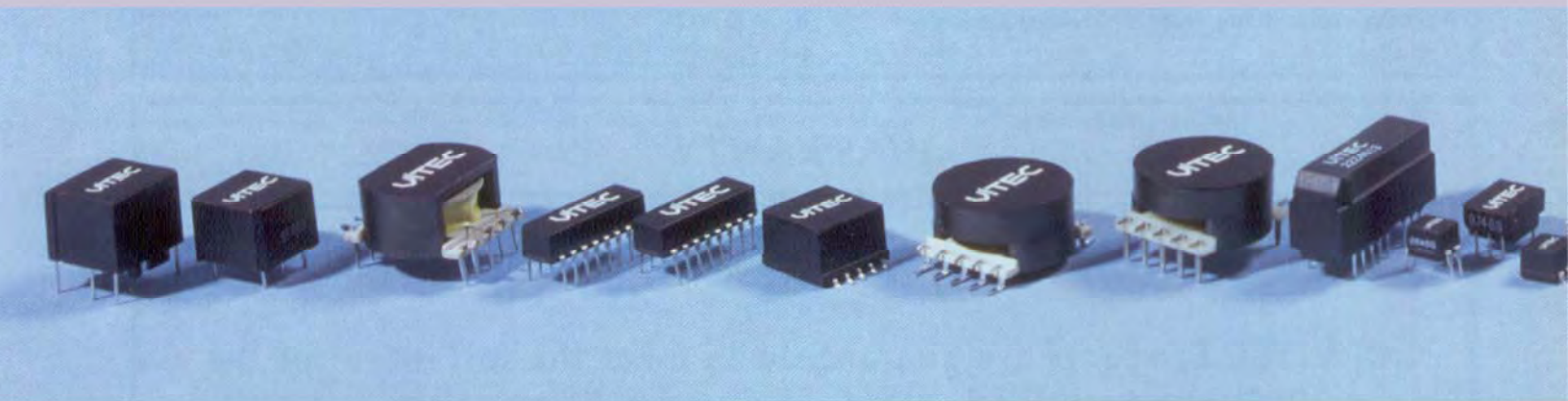

VITEC ELECTRONICS CORPORATION

www.VitecCorp.com